

# Rimoldi®

SPARE PARTS CATALOGUE  
CATALOGO PEZZI DI RICAMBIO  
CATALOGUE RECHANGES  
ERSATZTEILELISTE

F29-00-2CD-01	F29-00-2CD-23	F29-00-2MD-60
F29-00-2CD-03	F29-00-2CD-51	F29-00-2MD-60
F29-00-2CD-04	F29-00-2CD-55	F29-12-2CD-02
F29-00-2CD-05	F29-00-2CD-60	F29-22-2CD-02
F29-00-2CD-06*	F29-00-2MD-05	F29-22-2CD-03
F29-00-2CD-10	F29-00-2MD-06	F29-22-2MD-04
F29-00-2CD-12	F29-00-2MD-10	F29-23-2CD-03
F29-00-2CD-15	F29-00-2MD-55	F29-23-2MD-04
F29-00-2CD-22	F29-00-2MD-56	F29-49-2MD-01

From the library of: Diamond Needle Corp

From the library of: Diamond Needle Corp

# FLEXSYSTEM®

## Vega

F29-00-2CD-01	F29-00-2CD-23	F29-00-2MD-60
F29-00-2CD-03	F29-00-2CD-51	F29-12-2CD-02
F29-00-2CD-04	F29-00-2CD-55	F29-22-2CD-02
F29-00-2CD-05	F29-00-2CD-60	F29-22-2CD-03
F29-00-2CD-06	F29-00-2MD-05	F29-22-2MD-04
F29-00-2CD-10	F29-00-2MD-06	F29-23-2CD-03
F29-00-2CD-12	F29-00-2MD-10	F29-23-2MD-04
F29-00-2CD-15	F29-00-2MD-55	F29-49-2MD-01
F29-00-2CD-22	F29-00-2MD-56	

1a EDIZIONE - EDITION 11/91 **n. 541**

From the library of: Diamond Needle Co.

**GUIDA PER LA CONSULTAZIONE  
DEL CATALOGO  
RICAMBI**

Il catalogo pezzi di ricambio è costituito da due parti:  
la prima illustra i particolari comuni a tutte le teste; la seconda comprende i particolari specifici, riuniti in moduli.

La composizione della testa interessata si ottiene consultando la tabella "COMPOSIZIONE TESTE Vega".

I particolari che compongono un gruppo sono riquadrati; i sottogruppi, anch'essi riquadrati, sono inseriti nel gruppo di appartenenza.

Tutti i particolari non fornibili scolti non vengono richiamati singolarmente, ma soltanto illustrati nel gruppo di appartenenza.

Per facilitare la ricerca viene riportato l'indice numerico di tutti i particolari comuni a tutte le teste, illustrati nella prima parte del catalogo.

Per ordinare gli aghi, precisare il simbolo riportato in catalogo; in caso di dubbio allegare un ago campione o una bustina vuota.

**GUIDELINES FOR THE USE  
OF SPARE PARTS  
CATALOGUE**

The spare parts catalogue is made up of 2 sections:  
the first section illustrates the common parts to all heads; the second section comprises the specific ones, combined in modules.

The head composition is obtained by consulting the table "COMPOSITION Vega HEADS".

The parts that are components of an assembly are represented within a square; the sub-assembly, also represented within a square, are included in the assembly they are part of.

All the parts which are not supplyable separately, are not described one by one, but only illustrated in the belonging group.

In order to find the pieces easily, a numerical index of the parts common to all heads is given in the first section of the catalogue.

When ordering needles, please specify catalogue symbol; if you have doubts, send a sample needle or an empty needle bag with your order.

**GUIDE A LA CONSULTATION  
DU CATALOGUE PIÈCES  
DE RECHANGE**

Le catalogue se compose de deux parties:  
la première illustre les pièces communes à toutes les têtes; la seconde se réfère aux pièces spécifiques, réunies en modules.

La composition de la tête intéressée s'obtient en consultant le tableau "COMPOSITION TÊTES Vega".

Les pièces qui composent un groupe sont bordées; les sous-groupes eux-mêmes bordés, sont insérés dans le groupe d'appartenance.

Toutes les pièces qui ne peuvent pas être fournies séparément ne sont pas rappelées individuellement mais uniquement illustrées dans le groupe d'appartenance.

Pour faciliter la recherche, dans la première partie du catalogue, on a reporté l'index numérique de toutes les pièces communes à toutes les têtes.

Pour les commandes d'aiguilles, préciser le symbole indiqué sur le catalogue, en cas de doute joindre une aiguille échantillon ou un sachet vide.

**ANLEITUNG FÜR DIE  
BENUTZUNG DES  
ERSATZTEILKATALOGES**

Der Ersatzteilkatalog besteht aus 2 Teilen:  
Im ersten sind die für jeden Grundnähkopf gleichen Teile eingetragen; im zweiten sind die spezifischen Teile zu finden, die Aufbaugruppen bilden.

Die Zusammenstellung des Nähkopfes erstelle man aufgrund der Tabelle "ZUSAMMENSTELLUNG DES Vega-NÄHKOPFES".

Alle Teile welche eine Teilegruppe bilden sind umrahmt; die Untergruppen, ebenfalls umrahmt, sind in der betreffenden Teilegruppe angeführt.

Die nicht los lieferbaren Teile sind nicht alleine sondern immer zusammen mit der Aufbaugruppe eingetragen.

Zur Erleichterung des Aufsuchens wurde im Katalog ein Verzeichnis von allen im ersten Teil eingetragenen Teilen eingearbeitet.

Für Aufträge über Nähadeln ist die im Ersatzteilkatalog angeführte Teilenummer anzugeben; in Zweifelsfällen ist eine Nadel als Muster oder ein entsprechender leerer Nadelbrief beizulegen.

**GUIA PARA LA CONSULTA  
DEL CATALOGO DE  
REPUESTOS**

El catálogo de repuestos está formado de dos partes:  
la primera ilustra los particulares comunes a todos los cabezales; la segunda comprende particulares específicos, agrupados en módulos.

La composición del cabezal deseado, se obtiene consultando la tabla "COMPOSICION CABEZAL Vega".

Los particulares que componen un grupo son encuadrados. Los subgrupos, aunque si son encuadrados, son insertados en el grupo de pertenencia.

Todos los particulares no suministrables sueltos no están señalados uno por uno, sino solamente ilustrados en el grupo al cual pertenecen.

Para facilitar el manejo figura un índice numerico de todos los particulares comunes a todos los cabezales, ilustrados en la primera parte del catalogo.

Por pedido de agujas, precisar el símbolo reproducido en el catálogo. En caso de duda, adjuntar un modelo o un sobre vacío.

From the Library of David and Netel



## CODIFICA TESTE Vega

Vega, che fa parte della filosofia produttiva Flexsystem, è un sistema modulare di cucitura, composto da un' Unità-Base e diversi Kit di Personalizzazione, con i quali si può ottenere la sottoclasse più idonea alle diverse operazioni di cucitura.

E' possibile identificare e ordinare le teste complete oppure le Unità-Base + Kit scelti di personalizzazione.

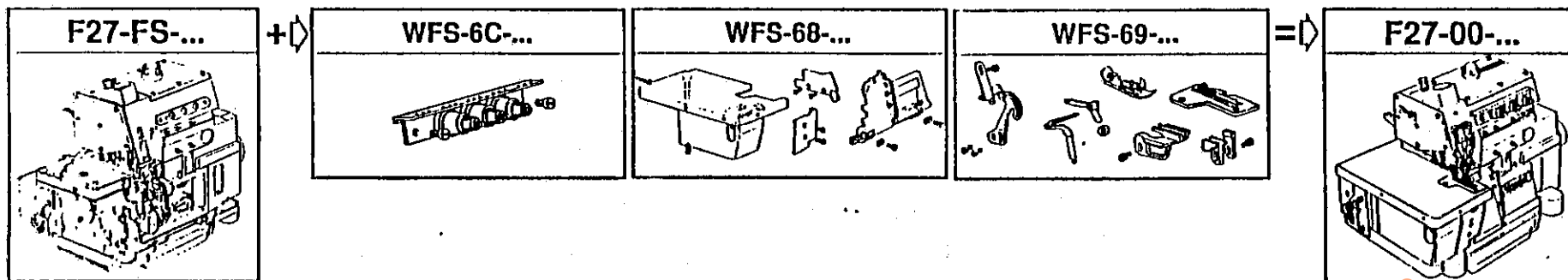

**Codice teste**  
**TF-XX-VV-YJK-ZZ**

**XX = Specifica classe:**

- 17 = overlock F17. Testa con estensione cilindrica al posto del piano di lavoro, per cuciture su capi tubolari.
- 27 = overlock F27. Testa con piano di lavoro normale.
- 29 = safety stitch F29.
- 20 = punto catenella F20.

**VV = Sigla alfanumerica del codice di impiego. La sigla FS (FLEXSYSTEM) identifica le teste "Unità Base".**

**Y = Numero aghi.**

**J = Eccentricità sollevamento griffe così utilizzata:**

- C=0,9 mm.
- M=1,1 mm.

**K = Tipo di trasporto.**

**ZZ = Sigla alfanumerica dei codici sequenziali che identificano la testa specifica o la famiglia di appartenenza per le teste "Unità Base".**

**Codice Kit di trasformazione e/o personalizzazione teste Vega**  
**WFS-XY-ZZZ-TW-U**

**X = Sigla alfanumerica che identifica le classi delle teste di appartenenza del Kit, così utilizzata:**

- A = Kit comuni a più classi di teste.
- 6 = Kit specifico per teste serie Vega.

**Y = Sigla alfanumerica che identifica le classi del Kit:**

- 1 = Kit puller.
- 3 = Kit rulli dosatori meccanici superiori.
- 5 = Kit attrezzature vari.
- 6 = Kit gruppo di comando.
- 8 = Kit carter.
- 9 = Kit campionatura.
- A = Kit elettronica di comando.
- B = Kit supporto porta.placca e affini.
- C = Kit tensioni.
- D = Kit dispositivi.
- S = Kit dispositivi ausiliari (rulli elett. sup. e inf., Lisa, etc.).

**ZZZ = Sigla alfanumerica per la sequenza delle classi del Kit.**

**TW-U = Sigla alfanumerica utilizzata nel seguente modo:**

a) Per tutti i Kit ad esclusione del Kit dispositivi (seconda posizione del codice=D).

TW-U = Sigla alfanumerica per l'indice di modifica.

b) Per Kit dispositivi (seconda posizione del codice=D).

T = Dispositivi di base e per abbinamenti, così utilizzato:

- A = Kit elettronici.
- B = Kit di base.
- S = Kit di servizio (es. filtri).
- C = Kit per PL-MO-UP-UR.
- W = Sigla alfanumerica per dispositivi speciali.
- M = Provvisorio per usi interni.
- U = Sigla alfanumerica per indice di modifica.

## CODIFICATION OF Vega HEADS

Vega, part of the Flexsystem productive philosophy, is a sewing modular system, composed by one Unit-Base and different Personalizing Kits, which allow to obtain the most suitable subclass for the different sewing operations.

It is possible to identify and order both the complete heads and the Unit-Base + loose Personalizing Kits.

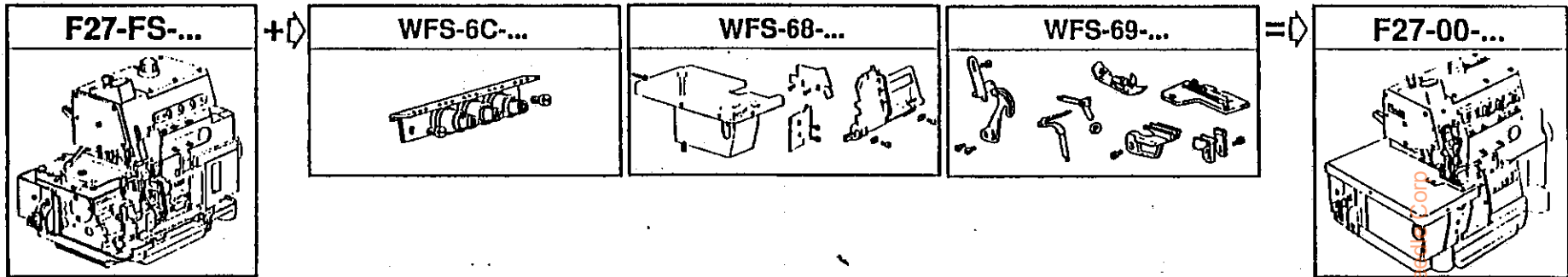

	<b>Heads code</b> <b>TF-XX-VV-YJK-ZZ</b>	
--	---	--

	<b>Transformation and/or personalization kit code for Vega heads</b> <b>WFS-XY-ZZZ-TW-U</b>	
--	--	--

**XX = class specification :**

- 17=overlock F17. Head with cylindric extension instead of working plate, for sewing tubulars garments.
- 27=overlock F27. Head with normal working plate.
- 29=safety stitch F29.
- 20=chain stitch F20.

**VV = alphanumeric indication of use code.** The initials FS (FLEXSYSTEM) identifies the heads "Base Unit".

**Y = number of needles.**

**J = feed dog lifting eccentricity, used in the following way:**

- C=0.9 mm.
- M=1.1 mm.

**K = type of feed.**

**ZZ = alphanumeric indication of the sequential code which identifies the specific heads or family it belongs to heads "Base Unit".**

**X = alphanumeric character that identifies the class of heads the kit belongs to, used in the following way:**

- A = kit common to more than one class of head.
- 6 = Specific Kit for Vega class heads.

**Y = alphanumeric character which identifies the class of the kit:**

- 1 = Puller kit.
- 3 = upper mechanical metering roller kit.
- 5 = various tool kit.
- 6 = control assembly kit.
- 8 = cover kit.
- 9 = sampling kit.
- A = electronic control kit.
- B = needle plate holder and similar kit.
- C = tension kit.
- D = device kit.
- S = auxiliary device kit (upper electronic rollers and the like, Lisa etc.).

**ZZZ = alphanumeric character for the sequence of the class of the kit.**

**TWU = alphanumeric code used in the following way:**

- a) for all kits excluding the device kits (second position of the code=D).  
TWU = alphanumeric code for the modification index.
- b) for device kits (second position of the code=D).  
T = basic kits for combination, used in the following way:

- A = electronic kit.
- B = basic kit.
- S = service kit (ex. filters).
- C = Kit for PL-MO-UP-UR.
- W = alphanumeric code for special devices.
- M = provisional for internal use.
- U = alphanumeric symbol for modification index.

From the library of Diamant Museum 2019

## CODAGE TETES Vega

Vega, faisant partie de la philosophie productive Flexsystem, c'est un système modulaire de couture, composé par une Unité-Base et par des différents Kits de Personnalisation, par lesquels on peut obtenir la sous-classe la plus propre aux différents opérations de couture. Vous pouvez identifier et commander tant les têtes complètes que les Unités-Bas plus les Kits de personnalisation détachés.

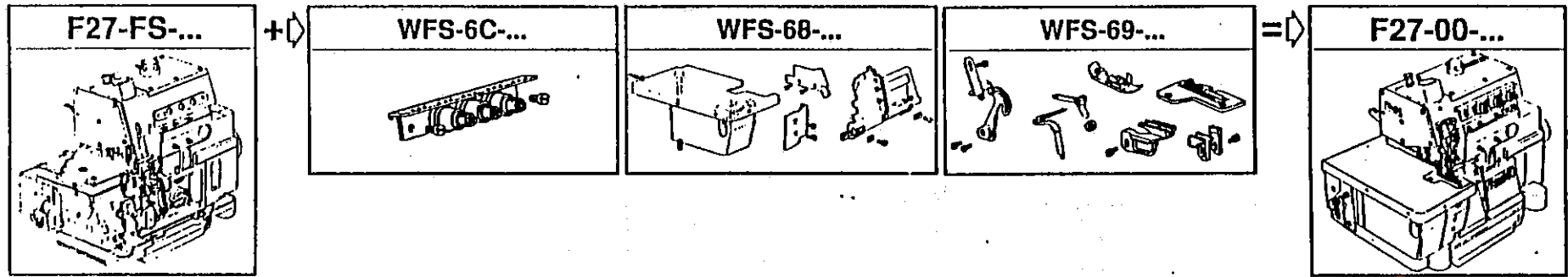

**Code têtes**  
TF-XX-VV-YJK-ZZ

**Code Kit de transformation et/ou personnalisation têtes Vega**  
WFS-XY-ZZZ-TW-U

XX = spécifie classe :

- 17 = overlock F17. Tête avec extension cylindrique en remplacement du plan de travail, pour couture sur articles tubulaires.
- 27 = overlock F27. Tête avec plan de travail normal.
- 29 = safety slich F29.
- 20 = point de chaînette F20.

VV = sigle alphanumérique du code d'utilisation. Le sigle FS (FLEXSYSTEM) identifie les têtes "Unité Base".

Y = numéro aiguilles.

J = excentricité soulèvement griffes, utilisé de la manière suivante:

- C=0,9 mm.
- M=1,1 mm.

K = type d'entraînement.

ZZ = sigle alphanumérique des codes séquentiels qui identifient la tête spécifique ou la famille d'appartenance pour les têtes "Unité Base".

X= sigle alphanumérique qui identifie les classes des têtes d'appartenance du Kit, utilisé de la manière suivant:

- A=Kits communs à plusieurs classes de têtes.
- 6=Spécifique pour têtes serles Vega.

Y= sigle alphanumérique qui identifie les classes du Kit:

- 1=Kit puller.
- 3=Kit rouleaux doseurs mécaniques supérieurs.
- 5=Kit équipements divers.
- 6=Kit groupes de commande.
- 8=Kit carter.
- 9=Kit échantillonnage.
- A=Kit électronique de commande.
- B=Kit support porte plaque et similaires.
- C=Kit tensions.
- D=Kit dispositifs.
- S=Kit dispositifs auxiliaires (rouleaux électr. sup. et inf., Lisa, etc.).

ZZZ= sigle alphanumérique pour la séquence des classes des Kits.

TW-U= sigle alphanumérique utilisé de la manière suivante:

- a) pour tous les Kits sauf les Kits dispositifs (deuxième position du code=D). TW-U= sigle alphanumérique pour l'index de modification.
- b) pour les Kits dispositifs (deuxième position du code=D). T=Dispositifs de base et pour accouplements, utilisé de la manière suivante:
  - A=Kits électroniques.
  - B=Kit de base.
  - S=Kit de service (par ex. filtres).
  - C=Kit pour PL-MO-UP-UR.
  - W= sigle alphanumérique pour dispositifs spéciaux.
  - M=provisoire pour usages intérieurs.
  - U= sigle alphanumérique pour index de modification.

For the list of Damol Needles visit



## CODIFIZIERUNG DER Vega OBERTEILE

Vega, das zur Flexsystem produktiven philosophie gehört, ist ein moduliertes nährsystem das von Einer Grundheilt und verschiedenen Personalifizierungskit zusammengesetzt ist, die die lähigsten subklasse für die verschie denen nähroperationen erreichen lässt. Sie können vollständige köpfe als auch die grundheilt + gelöste personalifizierungskit identifzieren und bestellen.

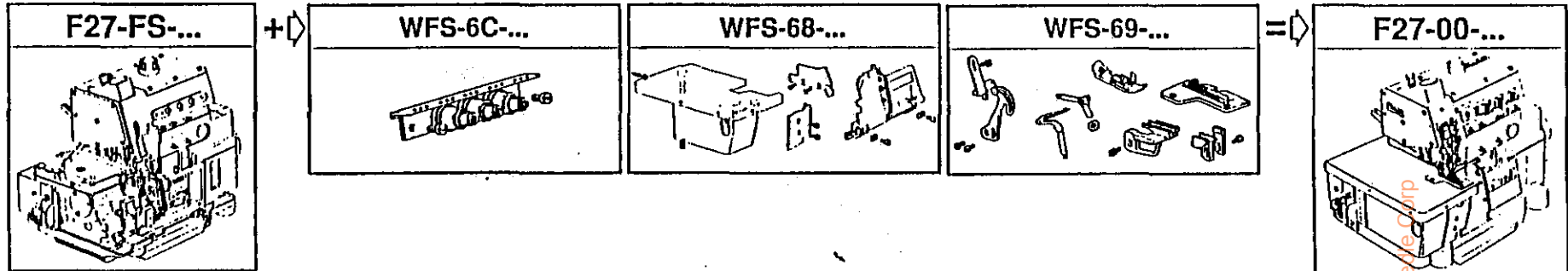

**Symbol für Oberteil**  
TF-XX-VV-YJK-ZZ

**Simbol Umbausatz und/oder personalisierung der Vega Oberteil**  
WFS-XY-ZZZ-TW-U

**XX = Klassenspezifikation:**

- 17 = Überwendlichmaschine F17. Zylindrischer basis Oberteil statt arbeits plate, zum saeu men schlauchware.
- 27 = Überwendlichmaschine F27. Oberteil mit normaler arbeits plate.
- 29 = Sicherheitsstich F29.
- 20 = Kettenstich F20.

**VV = Zahlensymbol des Einsatzcodex. Symbol FS (FLEXSYSTEM) welcher die "Klasse Base" angibt.**

**Y = Nadelzahl.**

**J = Exzentrizität der Transporteurfüllung, wie folgt:**

- C=0,9 mm.
- M=1,1 mm.

**K = Transportart.**

**ZZ = Zahlensymbol für Sequenzcodex, welcher die Maschinenfamilie oder den oberteil bezeichnet für "Klasse Base".**

**X = Zahlensymbol der Maschinenklasse zu welcher der Umbausatz gehört, wie folgt:**

- A= Umbausätze für mehrere Maschinenklassen.
- 6= Spezielle Kit für Vega oberteile.

**Y = Zahlensymbol, welcher die Klassen des Umbausatzes (Kit) angibt:**

- 1 = Kit Puller.
- 3 = Kit mech. obere Dosierungsrollen.
- 5 = Kit für verschiedene Ausrüstungen.
- 6 = Kit für Steuergruppen.
- 8 = Kit für Gehäuse.
- 9 = Kit für Einnähen.
- A = Kit elektronische Steuerung.
- B = Kit Stichplattenhalter usw.
- C = Kit für Spannungen.
- D = Kit für Vorrichtungen.
- S = Hilfsvorrichtungen (obere und untere elektr. Walzen, Lisa, usw.).

**ZZZ = Zahlensymbol für die Klassensequenz der Umbausätze.**

**TW-U = Zahlensymbol wie folgt:**

- a) für alle Umbausätze ausser für Kit Vorrichtungen (zweiter Symbol=D).  
TW-U = Zahlensymbol für Umbau-Index.
- b) Kit für Vorrichtungen (zweiter Symbol=D).  
T = Base-Vorrichtungen und für Kupplungen, wie folgt:

- A = elektronische Kit.
- B = Base Kit.
- S = Service Kit (z.B. Filter).
- C = Kit für PL-MO-UP-UR.
- W = Zahlensymbol für Sondervorrichtungen.
- M = provisorisch für interne Zwecke.
- U = Zahlensymbol für Umbauindex.

## CODIFICACION CABEZALES Vega

Vega, que forma parte de la filosofía productiva Flexsystem, es un sistema modular de costura, compuesto por una Unidad-base y diferentes Kit de Personalización, con los cuales se puede obtener la subclase más idonea para las diferentes operaciones de costura.

Es posible identificar y solicitar los cabezales completos o bien las Unidades-Base + Kit de personalización sueltos.

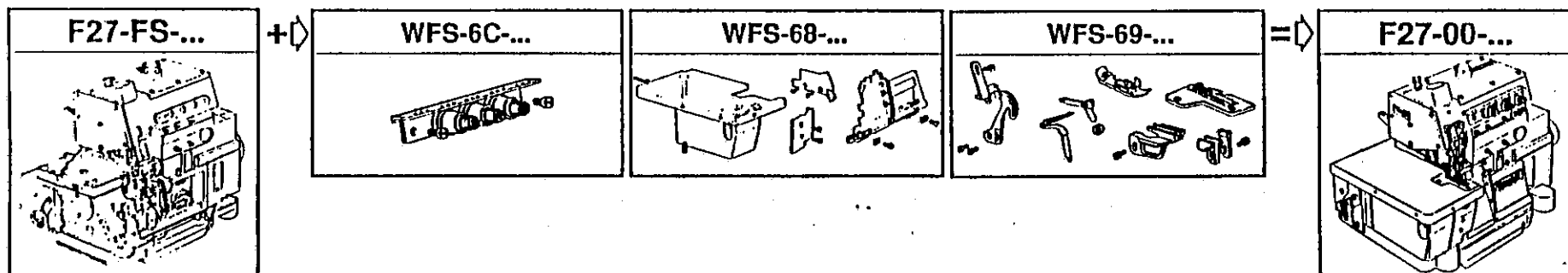

	Códigos cabezales TF-XX-VV-YJK-ZZ	
--	--------------------------------------	--

XX = especifica clase:

- 17=overlock F17. Cabezal con extension cilindrica en sustitucion del plano de trabajo, para costuras de prendas tubulares.
- 27=overlock F27. Cabezal con puesto de trabajo normal.
- 29=safely stitch F29.
- 20=punto catenella F20.

VV = sigla alfanumérica del código de empleo. La sigla FS (FLEXSYSTEM) identifica los cabezales "Unidad Base".

Y = numero agujas.

J = excentricidad levantamiento garfios, utilizada en el siguiente modo:

C=0,9 mm.  
M=1,1 mm.

K = tipo de transporte.

ZZ = sigla alfanumérica de los códigos secuenciales que identifican los cabezales específico o la familia de pertenencia por los cabezales "Unidad Base".

	Códigos Kit de transformación y/o personalización cabezales Vega WFS-XY-ZZZ-TW-U	
--	---	--

X = sigla alfanumérica que identifica las clases de los cabezales de pertenencia del Kit, utilizada en el siguiente modo:

- A = Kit comunes a diferentes tipos de cabezales.
- 6 = Kit específicos cabezales serie Vega.

Y = sigla alfanumérica que identifica las clases del Kit:

- 1 = Kit puller.
- 3 = Kit rollos dosadores mecánicos superiores.
- 5 = Kit aparatos varios.
- 6 = Kit grupos de mando.
- 8 = Kit carter.
- 9 = Kit puesta a punto.
- A = Kit electrónico de mando.
- B = Kit soporte porta placa y similares.
- C = Kit tensiones.
- D = Kit dispositivos.
- S = Kit dispositivos auxiliares (rollos electr. sup. e Int., Lisa, etc.).

ZZZ = sigla alfanumérica para la secuencia de las clases de los Kit.

TW-U = sigla alfanumérica utilizada en el siguiente modo:

a) para todos los Kit excluyendo los Kit dispositivos (segunda posición del código=D).

TW-U = sigla alfanumérica para el índice de modificación.

b) para Kit dispositivos (segunda posición del código=D).

T = Dispositivos de base y para combinaciones, utilizada en el siguiente modo:

- A = Kit electrónicos.
- B = Kit de base.
- S = Kit de servicio (ej. filtros).
- C = Kit para PL-MO-UP-UR.
- W = sigla alfanumérica para dispositivos especiales.
- M = provisional para usos internos.
- U = sigla alfanumérica para el índice de modificación.

Frontera Librería: D. and S. edito corp

Vega

## TABELLA PER COMPOSIZIONE TESTE - COMPOSITION TABLE OF HEAD

F29

## GRUPPI DI COMPOSIZIONE - COMPOSITION KITS

(2/3 AGII)  
(2/3 NEEDLES)

TESTA HEAD	UNITA' BASE BASE UNIT FLEXSYSTEM	TENSIONI TENSIONS WFS-6C			ATTREZ. VARE VARIOUS EQUIPMENT WFS-65	GRUPPO COMAN. CONTROL ASSEMBLY WFS-66	CARTER COVER WFS-68	KIT CAMPIONAT. SETTING KIT WFS-69			
F29-00-2CD-51	F29-FS-2CD-BA	005-00-0					011-00-0	001-00-0			
F29-00-2CD-55	F29-FS-2CD-BA	005-00-0					011-00-0	004-00-0			
F29-00-2CD-60	F29-FS-2CD-BB	005-00-0					011-00-0	006-00-0			
F29-00-2MD-05	F29-FS-2MD-AP	005-00-0					005-00-0	010-00-0			
F29-00-2MD-06	F29-FS-2MD-AP	005-00-0					005-00-0	011-00-0			
F29-00-2MD-10	F29-FS-2MD-AP	005-00-0					005-00-0	012-00-0			
F29-00-2MD-55	F29-FS-2MD-BC	005-00-0					011-00-0	010-00-0			
F29-00-2MD-56	F29-FS-2MD-BC	005-00-0					011-00-0	011-00-0			
F29-00-2MD-60	F29-FS-2MD-DC	005-00-0					011-00-0	012-00-0			
F29-12-2CD-02	F29-FS-2CD-AM	005-00-0					006-00-0	018-00-0			

From the library of: Diamond Needle Corp

\*IN FUNZIONE DEL PIAZZAMENTO - IN FUNCTION OF THE PLACEMENT - EN FONCTION DU PLACEMENT - IN ABHAENIGKEIT VON AUFSTELLUNG - EN FUNCION DE LA COLOCACION

Vega		TABELLA PER COMPOSIZIONE TESTE - COMPOSITION TABLE OF HEAD									F29
GRUPPI DI COMPOSIZIONE - COMPOSITION KITS											(2/3 AGHI) (2/3 NEEDLES)
TESTA HEAD	UNITA' BASE BASE UNIT FLEXSYSTEM	TENSIONI TENSIONS WFS-6C			ATTREZ. VARE VARIOUS EQUIPMENT WFS-65	GRUPPO COMAN. CONTROL ASSEMBLY WFS-66	CARTER COVER WFS-68	KIT CAMPIONAT. SETTING KIT WFS-69			
F29-00-2CD-01	F29-FS-2CD-AM	005-00-0					005-00-0	001-00-0			
F29-00-2CD-03	F29-FS-2CD-AM	005-00-0					005-00-0	002-00-0			
F29-00-2CD-04	F29-FS-2CD-AM	005-00-0					005-00-0	003-00-0			
F29-00-2CD-05	F29-FS-2CD-AM	005-00-0					005-00-0	004-00-0			
F29-00-2CD-06	F29-FS-2CD-AN	005-00-0					005-00-0	005-00-0			
F29-00-2CD-10	F29-FS-2CD-AN	005-00-0					005-00-0	006-00-0			
F29-00-2CD-12	F29-FS-2CD-AM	005-00-0					005-00-0	007-00-0			
F29-00-2CD-15	F29-FS-2CD-AM	005-00-0					005-00-0	008-00-0			
F29-00-2CD-22	F29-FS-2CD-AM	005-00-0					005-00-0	009-00-0			
F29-00-2CD-23	F29-FS-2CD-AM	005-00-0					005-00-0	015-00-0			

From the library of: Diamond Needle Corp









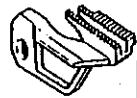

Vega		TABELLA PER COMPOSIZIONE TESTE - COMPOSITION TABLE OF HEAD								F29	
GRUPPI DI COMPOSIZIONE - COMPOSITION KITS										(2/3 AGI1) (2/3 NEEDLES)	
TESTA HEAD	UNITA' BASE BASE UNIT FLEXSYSTEM	TENSIONI TENSIONS WFS-6C			ATTREZ. VARE VARIOUS EQUIPMENT WFS-65	GRUPPO COMAN. CONTROL ASSEMBLY WFS-66	CARTER COVER WFS-68	KIT CAMPIONAT. SETTING KIT WFS-69			
F29-22-2CD-02	F29-FS-2CD-AM	005-00-0				001-00-0* 002-00-0*	005-00-0	019-00-0			
F29-22-2CD-03	F29-FS-2CD-AM	005-00-0				001-00-0* 002-00-0*	005-00-0	020-00-0			
F29-22-2MD-04	F29-FS-2MD-AP	005-00-0				001-00-0* 002-00-0*	005-00-0	021-00-0			
F29-23-2CD-03	F29-FS-2CD-AM	005-00-0			001-00-0	001-00-0* 002-00-0*	005-00-0	022-00-0			
F29-23-2MD-04	F29-FS-2MD-AP	005-00-0			001-00-0	001-00-0* 002-00-0*	005-00-0	023-00-0			
F29-49-2MD-01	F29-FS-2MD-AP	005-00-0					005-00-0	024-00-0			

From the library of: Diamond Needle Corp

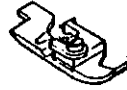
\*IN FUNZIONE DEL PIAZZAMENTO - IN FUNCTION OF THE PLACEMENT - EN FONCTION DU PLACEMENT - IN ABHÄNGIGKEIT VON AUFSTELLUNG - EN FUNCION DE LA COLOCACION

Vega		ORGANI DI CUCITURA - SEWING PARTS - ORGANES DE COUTURE - NAEHWLHKZEUGE - ORGANOS DE COSTURA												F-29	
		R - A RICHIESTA G - GRIFFA GOMMATA ■▲▲● - ABBINAMENTI OBBLIGATORI		- ON REQUEST - RUBBERED FEED DOG - FIXED COUPLINGS		- SUR DEMANDE - GRIFFE CAOUTCHOUTEE - JUMELAGES OBLIGES		- AUF ANFRAGE - GUMMBELEGTEH TRANSPORTUREN - PFLICHT KOPPELUNGEN		- CON SOLICITUD - DIENTE ENGOMADO - COMBINACIONES OBLIGATORIAS		(2/3 AGH1) (2/3 NEEDLES)			
TESTA HEAD TETE MASCHINE CABEZAL															
F29-00-2CD-01	211638-0-00	3,5	204666-0-13	1,5	211639-0-00	1,5	202609-0-20	1,5	204950-3-12	209356-0-00	204693-0-11	209264-0-10	211247-0-00	211310-0-00	
	211636-0-00 R	5,5	204806-2-12 R	G	211640-0-00 R	1,5				209355-0-00 R	207020-2-01 R	209268-0-00 R	211248-0-00 R		
	211637-0-00 R	4,2	204998-0-01 R	1,5	211641-0-00 R	G				209357-0-00 R					
			205537-0-01 R	1,5	211642-0-00 R	1,5				209358-0-00 R					
F29-00-2CD-03	204821-0-12	3	204813-0-13	1,5	204816-0-10	1,5	204819-0-10	1,5	204826-3-11	209356-0-00	204693-0-11	209264-0-10	211247-0-00	211310-0-00	
	204837-0-01 R	3,2	205539-0-01 R	1,5	205538-0-00 R	1,5			205084-3-11 R	209355-0-00 R	207020-2-01 R	209268-0-00 R	211248-0-00 R		
	204838-0-01 R	5								209357-0-00 R					
	205082-0-11 R	2,5								209358-0-00 R					
F29-00-2CD-04	208075-0-00	3	208076-0-00	1,5	204817-0-10	1,5	204819-0-10	1,5	204827-3-11 205085-3-11 R	209356-0-00 209355-0-00 R 209357-0-00 R 209358-0-00 R	204693-0-11 207020-2-01 R	209264-0-10 209268-0-00 R	211247-0-00 211248-0-00 R	211310-0-00 R	
F29-00-2CD-05	204864-0-13	5	204846-0-13	1,5	204850-0-10	1,5	202609-0-20	1,5	204950-3-12	209356-0-00	204693-0-11	209264-0-10	211247-0-00	211310-0-00	
	205102-0-13 R	3,5	204940-0-13 R	2	204851-0-11 R	1,5			205103-3-11 R	209355-0-00 R	207020-2-00 R	209268-0-00 R	211248-0-00 R		
			204941-0-13 R	2	204942-0-11 R	2				209357-0-00 R					
			204997-0-01 R	1,5	204943-0-11 R	2				209358-0-00 R					
F29-00-2CD-06	205025-0-12	5,5	205007-0-13	1,5	205011-0-10 R	1,5	202609-0-20	1,5	205070-3-12	209355-0-00	207020-2-01	209264-0-10	211247-0-00	211310-0-00	
	207051-0-02 R	2	205009-2-12 R	G	205013-2-11 R	G			207055-3-01 R	209356-0-00 R	204693-0-11 R	209268-0-00 R	211248-0-00 R		
			205059-0-13 R	2	205064-0-10 R	2				209357-0-00 R					
			205060-0-13 R	2	205065-0-10 R	2				209358-0-00 R					
			207052-0-02 R	1,5											
F27-00-2CD-10	205025-0-12	5,5	205060-0-13	2	205065-0-10	2	202609-0-20	1,5	205118-3-12	209355-0-00	207020-2-01	209264-0-10	211247-0-00	211310-0-00	
			205007-0-13 R	1,5	205011-0-10 R	1,5				209356-0-00 R	204693-0-11 R	209268-0-00 R	211248-0-00 R		
			205009-2-12 R	G	205013-2-11 R	G				209357-0-00 R					
			205059-0-13 R	2	205064-0-10 R	2				209358-0-00 R					

From the library of: Diana Needle Co.

Vega		ORGANI DI CUCITURA - SEWING PARTS - ORGANES DE COUTURE - NAEHWERKZEUGE - ORGANOS DE COSTURA												F29				
		R - A RICHIESTA G - GRIFFA GOMMATA ■▲● - ABBINAMENTI OBBLIGATORI	ON REQUEST - RUBBERED FEED DOG - FIXED COUPLINGS	SUR DEMANDE - GRIFFE CAOUTCHOUTEE - JUMELAGES OBLIGES	AUF ANFRAGE - GUMMIBELEGTEN TRANSPORTEUREN - PFLICHT KOPPELUNGEN	CON SOLICITUD - DIENTE ENGOMADO - COMBINACIONES OBLIGATORIAS						(2/3 AGH) (2/3 NEEDLES)						
TESTA HEAD TETE MASCHINE CABEZAL																		
F29-00-2CD-12	204864-0-13 204948-0-13	R 5 R 4	204941-0-13 204846-0-13 204940-0-13 204997-0-01A	2 1,5 R 1,5 R 2 R 1,5	204943-0-11 204850-0-10 204851-0-11A 204942-0-10	2 1,5 R 1,5 R 1,5 R 2	202609-0-20	1,5	206002-3-02	209355-0-00 209356-0-00 209357-0-00 209358-0-00	R R R R	207020-2-01 204693-0-11	R	209264-0-10 2092680-00	R	211247-0-00 211248-0-00	R	211310-0-00
F29-00-2CD-15	208043-0-02 208045-0-02	R 5 R 4,5	208042-0-10 208044-0-10	1,5 R 1,5	208053-0-10 208054-0-10	1,5 R 1,5	202609-0-20	1,5	204950-3-12	209356-0-00 209355-0-00 209357-0-00 209358-0-00	R R R R	204693-0-11 207020-2-01	R	209264-0-10 209268-0-00	R	211247-0-00 211248-0-00	R	211310-0-00
F29-00-2CD-22	205816-0-00 205815-0-00A 205832-0-00	R 3,7 R 5,5 R 4,5	205817-0-01	1,5	205818-0-00	1,5	205830-0-00	1,2	205824-3-10 205814-3-00A 205833-3-00	209356-0-00 209355-0-00 209357-0-00 209358-0-00	R R R R	204693-0-11 207020-2-01	R	209264-0-10 209268-0-00	R	211248-0-00 211247-0-00	R	211310-0-00
F29-00-2CD-23	208574-0-01	R 5,5	205825-0-01	1,5	208575-0-00	1,5	208576-0-00	1,2	205829-3-00	209355-0-00 209356-0-00 209357-0-00 209358-0-00	R R R R	207020-2-01 204693-0-11	R	209264-0-10 209268-0-00	R	211248-0-00 211247-0-00	R	211310-0-00
F29-00-2CD-51	211638-0-00 211636-0-00 211637-0-00	R 3,5 R 5,5 R 4,2	204666-0-13 204806-2-12 204998-0-01 205537-0-01A	1,5 R G R 1,5 R 1,5	211639-0-00 211640-0-00A 211641-0-00 211642-0-00	1,5 R 1,5 R G R 1,5	202609-0-20	1,5	204950-3-12	209356-0-00 209355-0-00 209357-0-00 209358-0-00	R R R R	204693-0-11 207020-2-01	R	209264-0-10 209268-0-00	R	211247-0-00 211248-0-00	R	211310-0-00
F29-00-2CD-55	204864-0-13 205102-0-13	R 5 R 3,5	204846-0-13 204940-0-13 204941-0-13A 204997-0-01	1,5 R 2 R 2 R 1,5	204850-0-10 204851-0-11 204942-0-11 204943-0-11A	1,5 R 1,5 R 2 R 2	202609-0-20	1,5	204950-3-12 205103-3-11	209356-0-00 209355-0-00 209357-0-00 209358-0-00	R R R R	204693-0-11 207020-2-00	R	209264-0-10 209268-0-00	R	211247-0-00 211248-0-00	R	211310-0-00

Vega		ORGANI DI CUCITURA - SEWING PARTS - ORGANES DE COUTURE - NAEHWERKZEUGE - ORGANOS DE COSTURA												F29				
R - A RICHIESTA G - GRIFFA GOMMATA *** - ABBINAMENTI OBBLIGATORI		- ON REQUEST - RUBBERED FEED DOG - FIXED COUPLINGS		- SUR DEMANDE - GRIFFE CAOUTCHOUEE - JUMELAGES OBLIGES		- AUF ANFRAGE - GUMMIBELEGTEN TRANSPORTEUREN - PFLICHT KOPPLUNGEN		- CON SOLICITUD - DIENTE ENGOMADO - COMBINACIONES OBLIGATORIAS		(2/3 AGHI) (2/3 NEEDLES)								
TESTA HEAD TETE MASCHINE CABEZAL																		
F29-00-2CD-60	205025-0-12	5,5	205060-0-13 205007-0-13 205009-2-12 205059-0-13	2 R 1,5 R G R 2	205065-0-10 205011-0-10 205013-2-11 205064-0-10	2 R 1,5 R G R 2	202609-0-20	1,5	205118-3-12	209355-0-00 209356-0-00 209357-0-00 209358-0-00	R R R R	207020-2-01 204693-0-11	R	209264-0-10 209268-0-00	R	211247-0-00 211248-0-00	R	211310-0-00
F29-00-2MD-05	209056-0-01	5,5	209059-0-00	2,5	209057-0-00	2,5	209058-0-00	1,5	207133-3-06	209340-0-00 209339-0-00 209341-0-00 209342-0-00	R R R R	209457-0-00		209264-0-10 209268-0-00	R	211247-0-00 211248-0-00	R	211310-0-00
F29-00-2MD-06	205025-0-12 207051-0-02	5,5 R 2	205007-0-13 205009-2-12 205059-0-13 205060-0-13 207052-0-02	1,5 R G R 2 R 2 R 1,5	205011-0-10 205013-2-11 205064-0-10 205065-0-10	1,5 R G R 2 R 2	202609-0-20	1,5	205070-3-12 207055-3-01	209351-0-00 209352-0-00 209353-0-00 209354-0-00	R R R R	207020-2-01 204693-0-11	R	209264-0-10 209268-0-00	R	211247-0-00 211248-0-00	R	211310-0-00
F29-00-2MD-10	205025-0-12	5,5	205060-0-13 205007-0-13 205009-2-12 205059-0-13	2 R 1,5 R G R 2	205065-0-10 205011-0-10 205013-2-11 205064-0-10	2 R 1,5 R G R 2	202609-0-20	1,5	205118-3-12	209351-0-00 209352-0-00 209353-0-00 209354-0-00	R R R R	207020-2-01 204693-0-11	R	209264-0-10 209268-0-00	R	211247-0-00 211248-0-00	R	211310-0-00
F29-00-2MD-55	209056-0-01	5,5	209059-0-00	2,5	209057-0-00	2,5	209058-0-00	1,5	207133-3-06	209340-0-00 209339-0-00 209341-0-00 209342-0-00	R R R R	209457-0-00		209264-0-10 209268-0-00	R	211247-0-00 211248-0-00	R	211310-0-00
F29-00-2MD-56	205025-0-12 207051-0-02	5,5 R 2	205007-0-13 205009-2-12 205059-0-13 205060-0-13 207052-0-02	1,5 R G R 2 R 2 R 1,5	205011-0-10 205013-2-11 205064-0-10 205065-0-10	1,5 R G R 2 R 2	202609-0-20	1,5	205070-3-12 207055-3-01	209351-0-00 209352-0-00 209353-0-00 209354-0-00	R R R R	207020-2-01 204693-0-11	R	209264-0-10 209268-0-00	R	211247-0-00 211248-0-00	R	211310-0-00

From the library of: Diana and Needle



Vega		ORGANI DI CUCITURA - SEWING PARTS - ORGANES DE COUTURE - NAEHWERKZEUGE - ORGANOS DE COSTURA													F29
		R - A RICHIESTA G - GRIFFA GOMMATA ■▲● - ABBINAMENTI OBBLIGATORI		- ON REQUEST - RUBBERED FEED DOG - FIXED COUPLINGS		- SUR DEMANDE - GRIFFE CAOUTCHOUTEE - JUMELAGES OBLIGES		- AUF ANFRAGE - GUMMIBELEGTEN TRANSPORTEUREN - PFLICHT KOPPELUNGEN		- CON SOLICITUD - DIENTE ENGOMADO - COMBINACIONES OBLIGATORIAS		(2/3 AGHI) (2/3 NEEDLES)			
TESTA HEAD TETE MASCHINE CABEZAL															
F29-00-2MD-50	205025-0-12	5,5	205060-0-13 205007-0-13 R 205009-2-12 R 205059-0-13 A	2 1,5 G 2	205065-0-10 205011-0-10 R 205013-2-11 R 205064-0-10 A	2 1,5 G 2	202609-0-20	1,5	205118-3-12	209351-0-00 209352-0-00 R 209353-0-00 R 209354-0-00 R	207020-2-01 204693-0-11 R	209264-0-10 209268-0-00 R	211247-0-00 211248-0-00 R	211310-0-00	
F29-12-2CD-02	206172-2-01	4,5	206176-0-03	1,5	204850-0-10	1,5	202609-0-20	1,5	204873-3-12	209356-0-00 209355-0-00 R 209357-0-00 R 209358-0-00 R	204693-0-11 207020-2-01 R	209264-0-10 209268-0-00 R	211248-0-00 211247-0-00 R	211310-0-00	
F29-22-2CD-02	208041-0-01	3	208040-0-00	1,5	204818-0-11	1,5	204819-0-10	1,5	204828-3-11	209356-0-00 209355-0-00 R 209357-0-00 R 209358-0-00 R	204693-0-11 207020-2-01 R	209264-0-10 209268-0-00 R	211247-0-00 211248-0-00 R	211310-0-00	
F29-22-2CD-03	208043-0-02 208045-0-02 R	5 4,5	208042-0-10 208044-0-10 A	1,5 1,5	208053-0-10 208054-0-10 A	1,5 1,5	202609-0-20	1,5	204875-3-12	209356-0-00 209355-0-00 R 209357-0-00 R 209358-0-00 R	204693-0-11 207020-2-01 R	209264-0-10 209268-0-00 R	211247-0-00 211248-0-00 R	211310-0-00	
F29-22-2MD-04	208048-0-10	5	208051-0-10 208046-0-10 R 208049-0-10 A	1,5 2 2	208052-0-10 208047-0-10 R 208050-0-10 A	1,5 2 2	202609-0-20	1,5	205034-3-12	209352-0-00 209351-0-00 R 209353-0-00 R 209354-0-00 R	204693-0-11 207020-2-01 R	209264-0-10 209268-0-00 R	211247-0-00 211248-0-00 R	211310-0-00	
F29-23-2CD-03	208043-0-02 208045-0-02 R	5 4,5	208042-0-10 208044-0-10 A	1,5 1,5	208053-0-10 208054-0-10 A	1,5 1,5	202609-0-20	1,5	204876-3-12	209356-0-00 209355-0-00 R 209357-0-00 R 209358-0-00 R	204693-0-11 207020-2-01 R	209264-0-10 209268-0-00 R	211247-0-00 211248-0-00 R	211310-0-00	

**Vega**      **ORGANI DI CUCITURA - SEWING PARTS - ORGANES DE COUTURE - NAEHWERKZEUGE - ORGANOS DE COSTURA**      **F29**

R - A RICHIESTA      - ON REQUEST      - SUR DEMANDE      - AUF ANFRAGE      - CON SOLICITUD  
 G - GRIFFA GOMMATA      - RUBBERED FEED DOG      - GRIFFE CAOUTCHOUTEE      - GUMMIBELAGTEN TRANSPORTEUREN      - DIENTE ENGOMADO  
 ■★★● - ABBINAMENTI OBBLIGATORI      - FIXED COUPLINGS      - JUMELAGES OBLIGES      - PFLICHT KOPPELUNGEN      - COMBINACIONES OBLIGATORIAS

(2/3 AGHI)  
(2/3 NEEDLES)

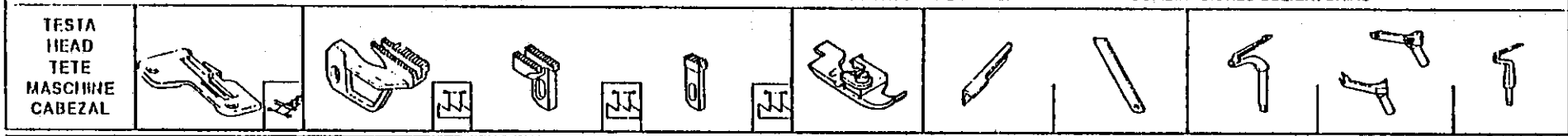

F29-23-2MD-04	208048-0-10	5	208051-0-10 208046-0-10 208049-0-10*	R 2 R 2 R 2	1,5	208052-0-10 208047-0-10 208050-0-10*	R 2 R 2 R 2	1,5	202609-0-20	1,5	205035-3-12	209352-0-00 209351-0-00 209353-0-00 209354-0-00	R R R R	204693-0-11 207020-2-01	R	209264-0-10 209268-0-00	R	211247-0-00 211248-0-00	R	211310-0-00
F29-49-2MD-01	207823-0-02	5	207810-0-01	2	207811-0-00	2	202609-0-20	1,5	207812-3-10	209351-0-00 209352-0-00 209353-0-00 209354-0-00	R R R R	207651-0-00	209264-0-10 209268-0-00	R	211247-0-00 211248-0-00	R	211310-0-00	R		

From the library of: Diamond Needle Co.

COLTELLO SUPERIORE - UPPER KNIFE - COUTEAU SUPERIEUR - OBERE MESSER - CUCHILLA SUPERIOR

209339-0-0

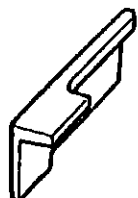

209340-0-00

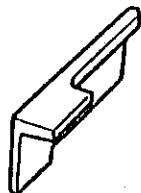

IN LEGA DURA  
WITH HARD ALLOYED  
EN ALLIAGE DUR  
MIT HARTMETAL  
EN ALEACION DURA

209341-0-00

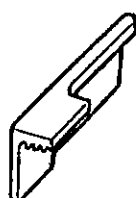

209342-0-00

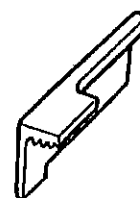

IN LEGA DURA  
WITH HARD ALLOYED  
EN ALLIAGE DUR  
MIT HARTMETAL  
EN ALEACION DURA

209351-0-00

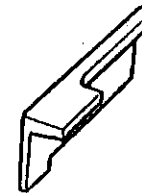

IN LEGA DURA  
WITH HARD ALLOYED  
EN ALLIAGE DUR  
MIT HARTMETAL  
EN ALEACION DURA

209352-0-00

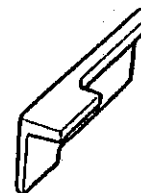

209353-0-00

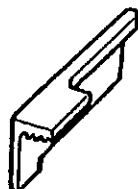

IN LEGA DURA  
WITH HARD ALLOYED  
EN ALLIAGE DUR  
MIT HARTMETAL  
EN ALEACION DURA

209354-0-00

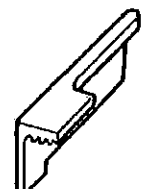

209355-0-00

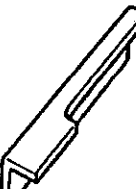

IN LEGA DURA  
WITH HARD ALLOYED  
EN ALLIAGE DUR  
MIT HARTMETAL  
EN ALEACION DURA

209356-0-00

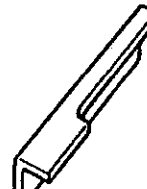

209357-0-00

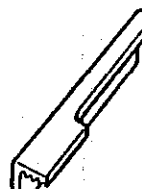

IN LEGA DURA  
WITH HARD ALLOYED  
EN ALLIAGE DUR  
MIT HARTMETAL  
EN ALEACION DURA

209358-0-00



From the library of: Diamond Needle Corp

COLTELLO INFERIORE - LOWER KNIFE - COUTEAU INFERIEUR - UNTERE MESSER - CUCHILLA INFERIOR

204693-0-11



207020-2-01



CON PLACCHETTA IN LEGA DURA  
WITH HARD ALLOYED PLATE  
AVEC PLAQUETTE EN ALLIAGE DUR  
MIT HARTMETAL-PLAETTCHEN  
CON PLACA EN ALEACION DURA

207651-0-00



209457-0-00



From the library of: Diamond Needle Corp

INDEX

SIMB.	TAV.	SIMB.	TAV.	SIMB.	TAV.	SIMB.	TAV.	SIMB.	TAV.	SIMB.	TAV.	SIMB.	TAV.
100620-2-10	3	207225-0-10	1	209378-0-00	4	210314-0-00	2	211213-0-00	6	311067-0-00	1	704860-0-00	7-8
201128-0-10	5-6-9	207602-0-00	1	209379-0-00	4	211013-0-00	13	211214-3-00	6	311166-0-00	5-6	704863-0-00	11
202032-0-11	3	207625-0-00	10	209383-0-00	12	211016-0-01	1	211218-2-00	6	313060-2-00	3-5-6-9	704873-0-00	6
202128-0-10	11	207626-0-00	10	209388-0-01	3	211017-0-01	1	211219-2-00	6	315895-0-00	12	704885-0-00	5-6
202129-0-10	11	207700-0-00	7-8	209389-0-00	1	211018-0-00	1	211224-2-00	5	321055-0-00	4	705008-0-00	7-8
202130-0-11	11	207719-0-00	3	209390-0-00	3	211019-0-00	1	211239-0-00	6	321206-0-00	13	705036-0-00	5-6
202214-0-11	10	207893-0-00	1	209400-0-00	3	211020-0-00	1	211241-2-00	6	350555-0-00	4	705208-0-00	3
202384-0-10	3	207948-0-00	4	209401-2-01	3	211031-2-00	11	211245-3-00	6	700005-0-00	4	705970-0-00	12
202386-0-10	2	207958-0-01	11	209402-0-00	3	211032-0-00	7	211250-2-00	5	700012-0-00	3	720411-2-00	13
202387-0-10	2	207959-0-00	10	209403-2-00	3	211033-0-00	2	211253-0-01	5-6	700116-0-00	12	720546-2-00	15-16
202389-0-10	2	207973-0-01	12	209408-2-00	3	211051-3-00	12	211276-2-10	5	700205-0-00	15-16	721424-2-00	1
202408-0-10	4-8	208015-0-00	5	209411-0-00	3	211052-0-00	12	211280-4-10	6	700207-0-00	3-8	721443-2-00	11
202490-0-10	3	208220-0-00	1	209417-0-00	1	211053-0-01	12	211281-0-00	5-6	700208-0-00	4	721473-2-00	2
202529-0-10	10	209020-0-00	18	209442-0-00	4	211054-0-00	1	211290-0-00	7-8	700630-0-00	2	721475-2-00	3-16
203135-2-10	1	209022-0-00	1	209443-0-10	4	211055-0-00	1	211295-0-00	4	701004-0-00	4-8-12	721883-0-00	5
204122-0-10	2	209048-3-10	13	209445-2-02	4	211056-0-00	1	211375-0-00	4	701005-0-00	6	722063-2-00	2-4-12-18
204757-0-11	2	209109-0-00	2	209447-0-02	4	211060-0-00	10	211381-0-00	4	701006-0-00	4-10-13	722089-2-00	5-6
205021-0-10	10	209110-4-00	2	209448-4-11	4	211061-0-00	10	211382-2-00	3	701007-0-00	3	722143-2-00	12
206090-0-10	1	209111-0-00	2	209449-0-00	4	211062-0-00	12	211385-0-00	4	701015-0-00	13	722149-2-00	9-11
206091-4-02	1	209143-0-01	9	209471-0-00	4	211063-0-00	12	211386-2-00	4	701031-0-00	12	722400-2-00	8
206437-0-00	12	209146-0-00	2	209500-0-10	10	211100-2-00	2	211387-2-00	3	701042-0-00	12	722421-2-00	10
206543-0-01	2	209185-0-00	2	209501-0-11	10	211103-2-00	2	211394-3-00	3	701114-0-00	11	722422-2-00	3
206550-4-05	12	209200-0-00	7-8	209503-0-10	10	211104-0-00	2	211405-0-00	3	701116-0-00	2	722431-2-00	17
206554-0-10	12	209258-0-00	5-7-8	209504-0-10	10	211106-2-00	9	211406-0-00	3	701123-0-00	12	722443-2-00	7-8
206556-0-01	2	209270-2-02	5-6	209521-0-00	10	211109-4-00	9	211407-0-00	3	701133-0-00	2	722461-2-00	2
206606-0-00	7-8	209272-0-00	5-6	209522-2-00	10	211110-0-00	9	211412-0-00	1	703005-0-00	17	722471-2-00	11
206622-0-00	10	209280-0-00	7-8	209524-2-00	10	211111-0-00	9	211413-0-00	1	703405-0-00	1	722511-2-00	12
206635-0-00	10	209282-0-00	8	209561-0-01	11	211112-0-00	9	211414-0-00	12	703802-0-00	4	722912-2-00	15-16
206637-0-00	10	209283-0-00	8	209569-2-02	11	211113-0-00	9	211416-0-00	1	704013-2-00	15-16	722920-2-00	15-16
206665-2-00	13	209293-2-01	7-8	209574-2-00	11	211114-0-00	9	211410-0-00	1	704017-2-00	17	724032-0-00	3
206681-0-00	2	209296-0-00	7-8	209577-0-01	11	211115-2-00	9	211427-3-00	4	704106-2-00	1	724430-2-00	4
206687-2-00	12	209297-0-00	7-8	209579-0-00	11	211116-0-00	9	211444-0-00	4	704213-2-00	9-11	725032-0-00	1
206688-0-00	12	209299-2-00	7-8	209580-2-01	11	211117-0-00	9	211612-0-01	3	704236-2-00	2	727036-2-00	5-6-9
206689-0-01	2	209300-0-00	8	209583-0-01	11	211119-0-00	9	211675-0-00	13	704302-4-00	8	727203-0-00	2
206690-2-00	12	209301-2-00	8	209587-0-00	11	211123-0-00	1	211683-0-00	1	704306-2-00	3	728232-0-00	4
206692-0-00	2	209303-0-00	8	209588-0-11	11	211125-0-00	9	211690-0-00	1	704314-2-00	4-8	729012-2-00	1-4
206693-0-00	2	209307-0-00	8	209589-2-00	11	211128-0-00	12	211740-0-00	1	704346-2-00	15-16	729013-2-00	3-5-6-9
206714-2-00	1	209308-0-00	7-8	209615-0-01	13	211129-4-00	9	211741-0-00	1	704406-2-00	11	729031-2-00	4-10
206740-0-00	1	209309-2-01	7-8	209624-0-11	13	211131-0-00	2	211745-0-00	1	704409-2-00	3-4-11-16	729033-2-00	4
206796-0-00	3	209311-2-00	7-8	209627-0-00	12	211132-3-00	9	211746-0-00	1	704424-2-00	15-16	729034-2-00	2-17
206798-0-00	3	209313-2-00	7	209633-0-00	12	211142-2-01	9	300482-0-10	11	704630-0-00	1	729064-2-00	6
206860-0-01	2	209316-0-00	12	209641-0-00	12	211202-0-00	6	304172-0-10	8	704813-0-00	12	730022-2-00	7-8-9
207219-0-10	1	209318-2-00	7-8	209693-0-00	3	211207-2-00	6	304195-0-10	8	704829-0-00	3	732425-0-00	14
207221-2-10	1	209320-2-00	2	209752-0-00	1	211208-4-00	6	307651-0-00	7-8	704841-0-00	7-8	732429-0-00	14
207224-0-10	1	209376-0-00	4	209760-0-00	1	211209-0-01	5-6	310724-0-00	6	704853-0-00	3-9	733008-2-00	15-16

SIMB.	TAV.	SIMB.	TAV.	SIMB.	TAV.	SIMB.	TAV.	SIMB.	TAV.	SIMB.	TAV.	SIMB.	TAV.
733211-2-00	17	778419-0-00	6	991143-0-10	17								
733505-2-00	17	778445-0-00	9	991172-0-00	17								
733507-2-00	7-8-12	778503-0-00	6	991179-0-01	17								
733508-2-00	17	783200-0-00	1	991187-0-01	15								
733806-0-00	17	790700-0-00	12	991188-0-02	16								
733806-2-00	3	790706-0-00	12	991193-4-00	17								
740087-2-00	4-10	790716-0-00	12	991199-0-00	17								
740277-2-00	7-8-10	900203-0-10	15-16	991206-0-00	17								
741387-2-00	7-8-12	900204-0-10	15-16	991219-0-00	17								
741415-2-00	5	900249-0-00	14	991246-2-00	17								
741558-0-00	7-8	900285-0-00	14	991264-2-00	17								
741611-2-00	4	900286-0-00	14	991267-0-00	17								
741634-2-00	1	900288-0-00	14	991268-0-00	17								
741657-0-00	1	900694-0-11	15-16	991269-2-00	17								
741745-2-00	3	901101-0-00	15-16	991279-2-00	17								
741925-2-00	12	901102-0-00	15-16	991349-0-00	15-16								
741936-2-00	3-4	901112-2-01	14	991383-0-10	17								
741937-2-00	1	901113-4-01	14	991415-0-00	18								
741956-2-00	2	901151-0-00	15-16	991466-4-00	18								
741967-2-00	1-3	901152-0-00	15-16	991512-0-00	18								
742086-2-00	12	901153-0-00	15-16	991650-0-00	18								
742232-2-00	7-8	922369-0-00	12	991750-0-01	15-16								
742457-2-00	11	925433-0-00	17	M488972020	15								
742675-0-00	2	926273-0-01	10										
742758-0-00	11	926409-0-01	12										
743243-2-00	7-8	941538-4-00	12										
743547-2-00	1	990176-0-10	18										
744332-2-00	3	990179-4-11	15-16										
744334-2-00	3-9-11	990223-0-02	18										
745002-0-00	1-6	990310-0-10	15-16										
745800-2-00	7-8	990311-0-10	15-16										
745810-2-00	1-5-6-9	990312-0-10	15-16										
745812-2-00	4-5-6-7	990314-0-10	15-16										
	8-9-10	990325-0-10	18										
745815-2-00	4-7-8	990474-0-11	18										
745827-2-00	3	990639-0-10	18										
746007-2-00	10	990685-0-10	18										
746021-2-00	10	990723-0-00	18										
746402-2-00	15-16	990979-0-00	18										
746409-2-00	15-16	990988-0-00	15-16										
778202-0-00	6	991111-2-00	17										
778204-0-00	6-9	991112-0-00	17										
778208-0-00	6	991134-0-00	17										
778403-0-00	6	991135-5-02	17										
778411-0-00	6	991137-2-02	17										

UNITA' BASE  
BASE UNIT  
UNITE DE BASE  
GRUENDLICHE EINHEIT  
UNIDAD BASE

Fig. N.	Part N. Piece N.	Qt.
1	211690-0-00	1
2	703405-0-00	2
3	725032-0-00	2
4	729012-2-00	1
5	741937-2-00	5
6	211412-0-00	1
7	211413-0-00	1
8	209752-0-00	1
9	211683-0-00	1
10	207224-0-10	2
11	207221-2-10	1
12	211019-0-00	1
13	211016-0-01	1
14	741967-2-00	20
15	211056-0-00	1
16	211418-0-00	1
17	211416-0-00	1
18	207602-0-00	1
19	207219-0-10	1
20	206090-0-10	1
21	207225-0-10	1
22	206091-4-02	1
23	721424-2-00	2
24	209389-0-00	1
25	211017-0-01	1
26	211018-0-00	1
27	207893-0-00	10
28	311067-0-00	1
29	209417-0-00	1
30	745810-2-00	1
31	206714-2-00	1
32	211740-0-00	1
33	741634-2-00	2
34	745002-0-00	1
35	203135-2-10	1
36	211745-0-00	1
37	211741-0-00	1
38	741657-0-00	1
39	209760-0-00	2
40	206740-0-00	2
41	783200-0-00	1
42	211054-0-00	1
43	211020-0-00	1
44	211123-0-00	3
45	704106-2-00	1
46	211746-0-00	1
47	743547-2-00	1
48	208220-0-00	1
49	704630-0-00	1
50	209022-0-00	1
51	211055-0-00	1

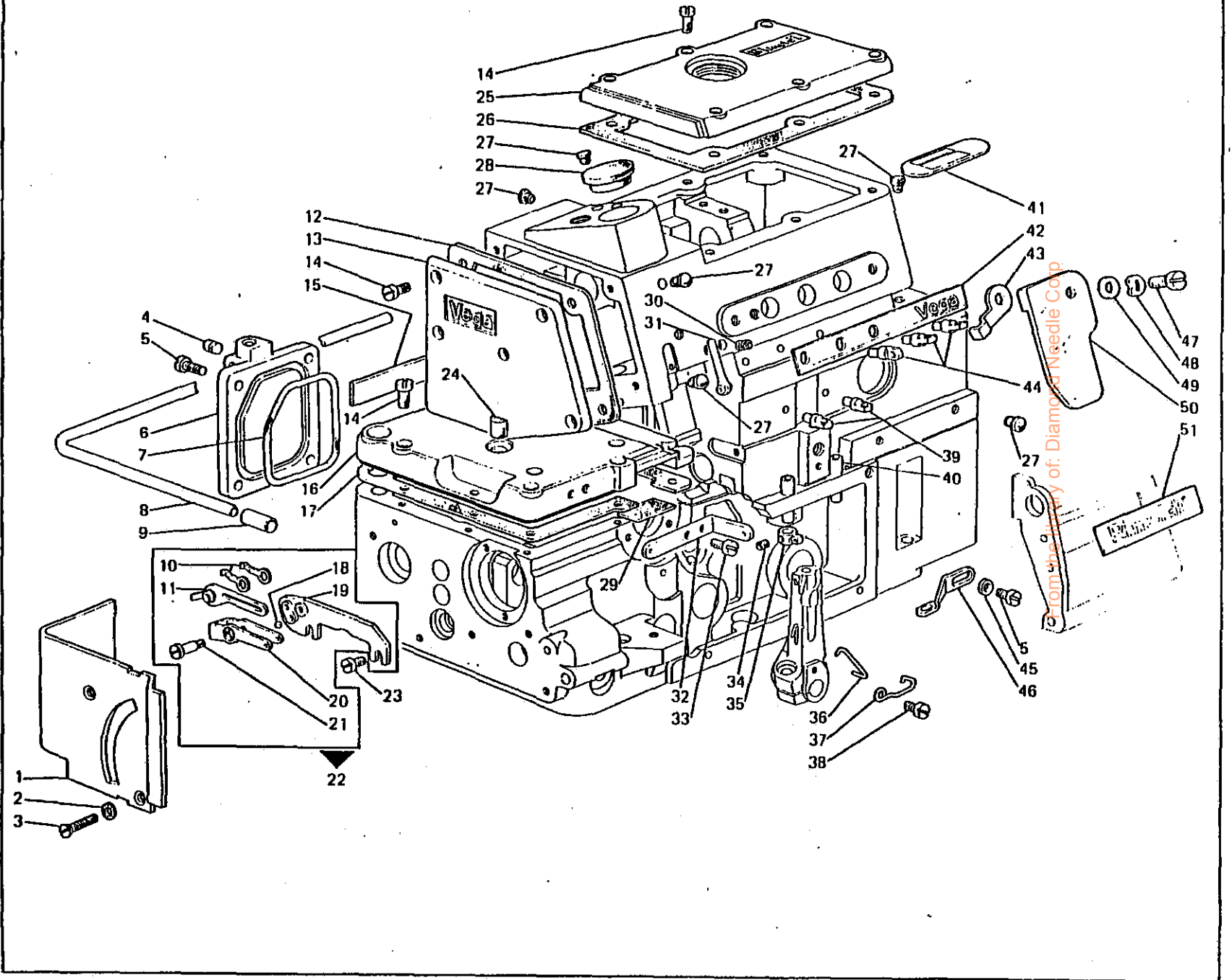



(A)

F29-FS-2CD-AM	211100-2-00
F29-FS-2CD-AN	211100-2-00
F29-FS-2CD-BA	211100-2-00
F29-FS-2CD-BB	211100-2-00
F29-FS-2MD-AP	211103-2-00
F29-FS-2MD-BC	211103-2-00

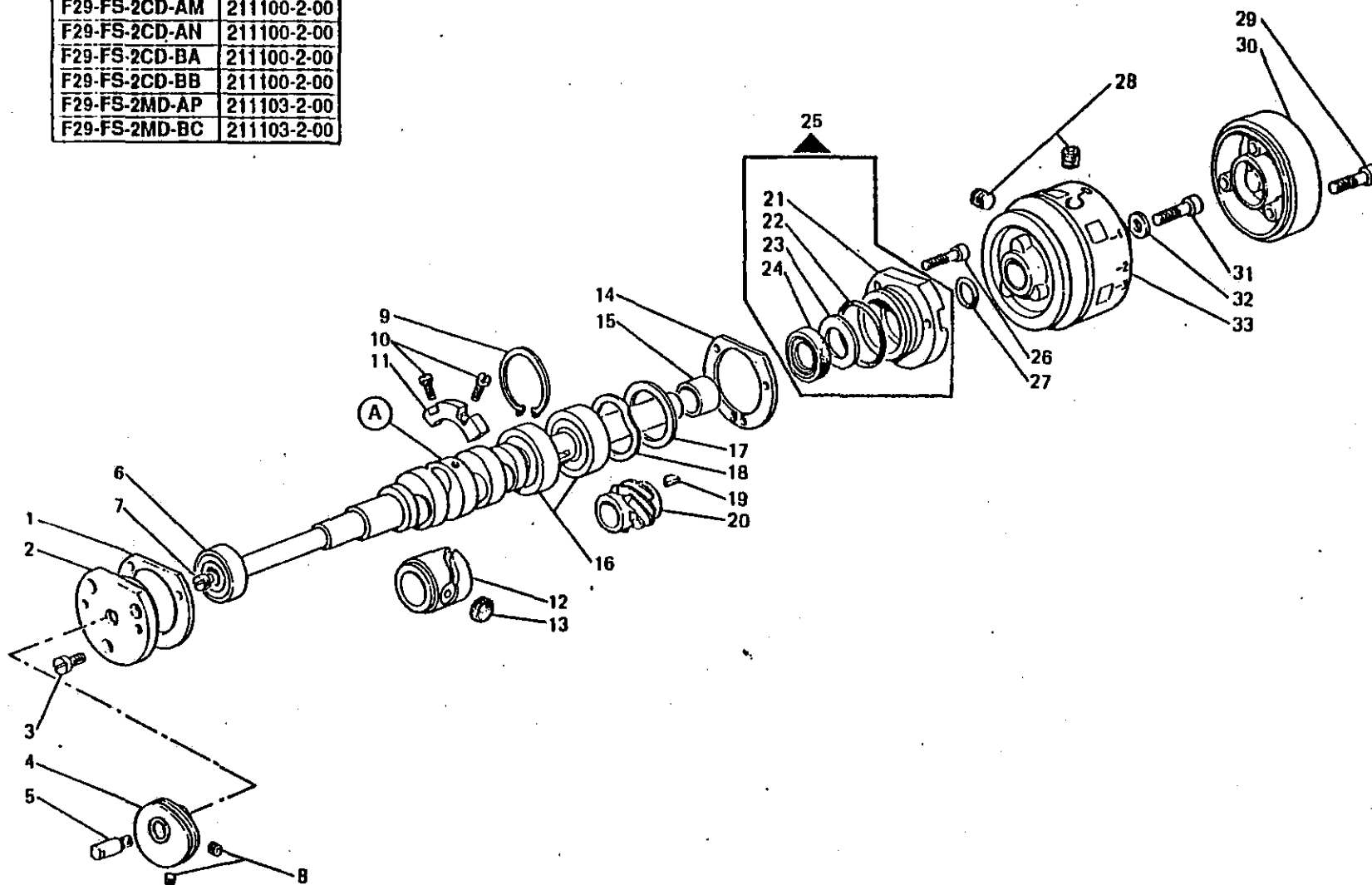

From the library of Diamond Machine Corp.

Fig. N.	Part. N. / Piece It.	Qt.
1	206543 0-01	1
2	206860 0-01	1
3	741956 2-00	1
4	209320 2-00	1
5	204757 0-11	1
6	202389 0-10	1
7	206681 0-00	1
8	727203 0-00	2
9	202386 0-10	1
10	721473 2-00	2
11	209146 0-00	1
12	211104 0-00	1
13	211033 0-00	1
14	209111 0-00	1
15	206692 0-00	1
16	202387 0-10	2
17	209185 0-00	1
18	206689 0-01	1
19	204122 0-10	1
20	206556 0-01	1
21	209109 0-00	1
22	701133 0-00	1
23	206693 0-00	1
24	700630 0-00	1
25	209110 4-00	1
26	722063 2-00	3
27	701116 0-00	1
28	729034 2-00	2
29	722461 2-00	3
30	211131 0-00	1
31	742675 0-00	1
32	704236 2-00	1
33	210314 0-00	1

# Rim<sup>®</sup> TAV. 3

## COMANDO GRIFFE - FEED DOGS CONTROL - COMMANDE GRIFFES - TRANSPORTEURANTRIEB - MANDO DIENTES

Fig. N.	Part. N. / Piece N.	Qt.
1	209693-0-00	1
2	704409-2-00	2
3	721475-2-00	2
4	206798-0-00	1
5	206798-0-00	1
6	700207-0-00	1
7	211612-0-01	2
8	729013-2-00	2
9	313060-2-00	1
10	704853-0-00	2
11	211408-0-00	1
12	700012-0-00	1
13	211405-0-00	1
14	701007-0-00	1
15	209411-0-00	1
16	209408-2-00	1
17	207719-0-00	1
18	724032-0-00	1
19	209402-0-00	1
20	744334-2-00	1
21	741967-2-00	2
22	211382-2-00	1
23	202384-0-10	1
24	209390-0-00	1
25	741745-2-00	1
26	100620-2-10	1
27	704829-0-00	1
28	209400-0-00	2
29	211394-3-00	1
30	745827-2-00	2
31	741936-2-00	4
32	209401-2-01	1
33	722422-2-00	1
34	209403-2-00	1
35	209388-0-01	1
36	744332-2-00	1
37	202490-0-10	2
38	705208-0-00	2
39	202032-0-11	2
40	211387-2-00	1
41	704308-2-00	1
42	733808-2-00	1
43	211407-0-00	1

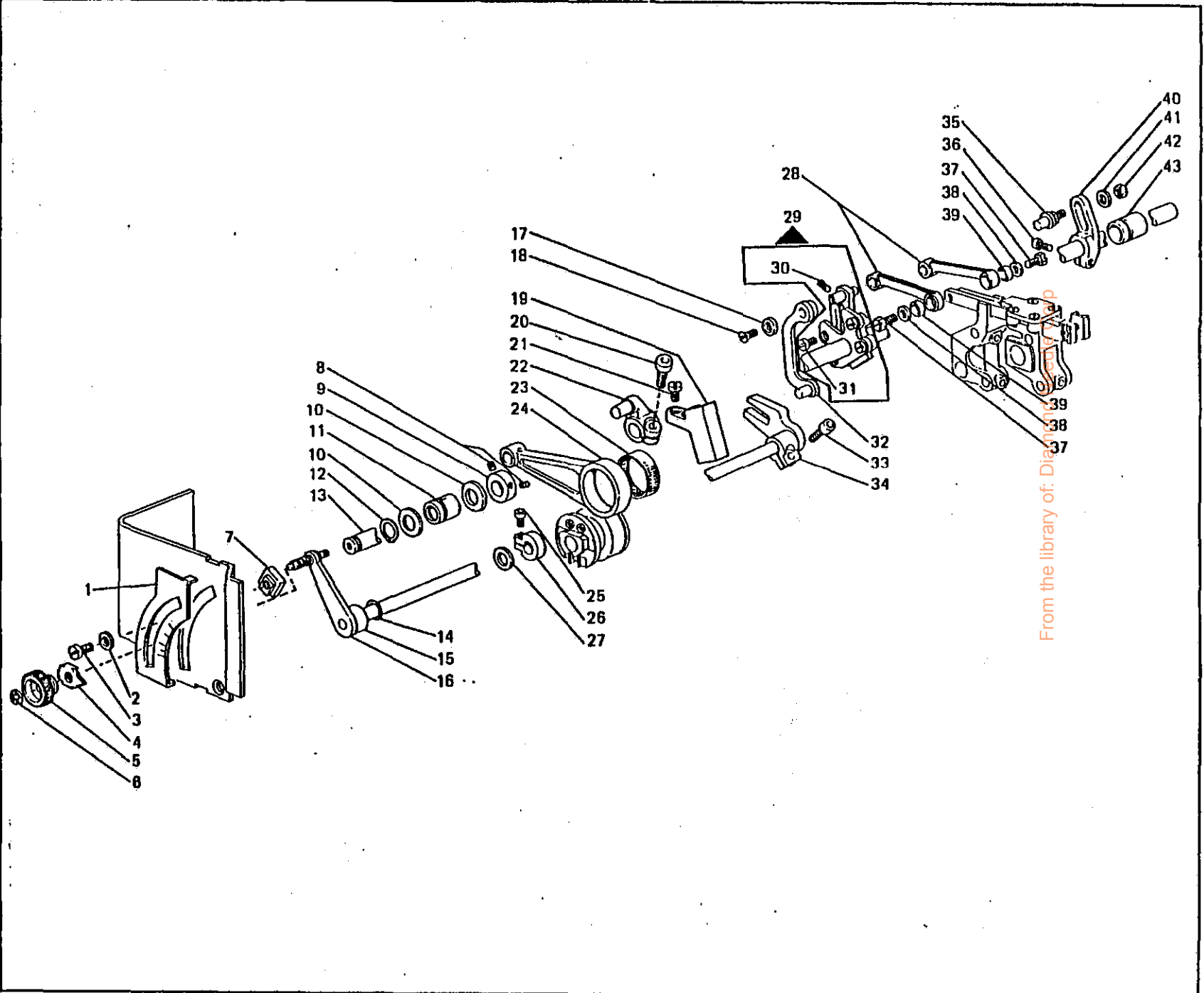

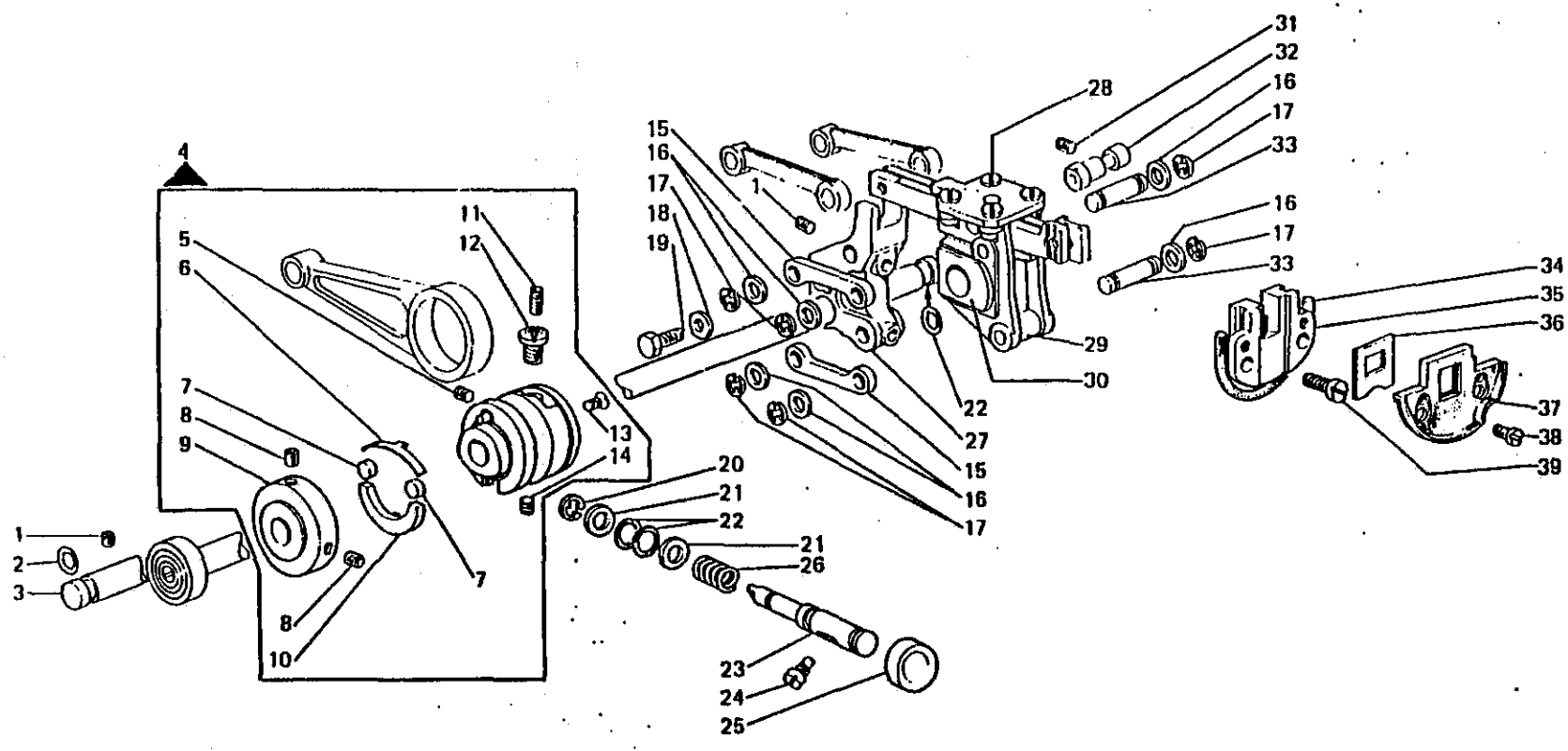
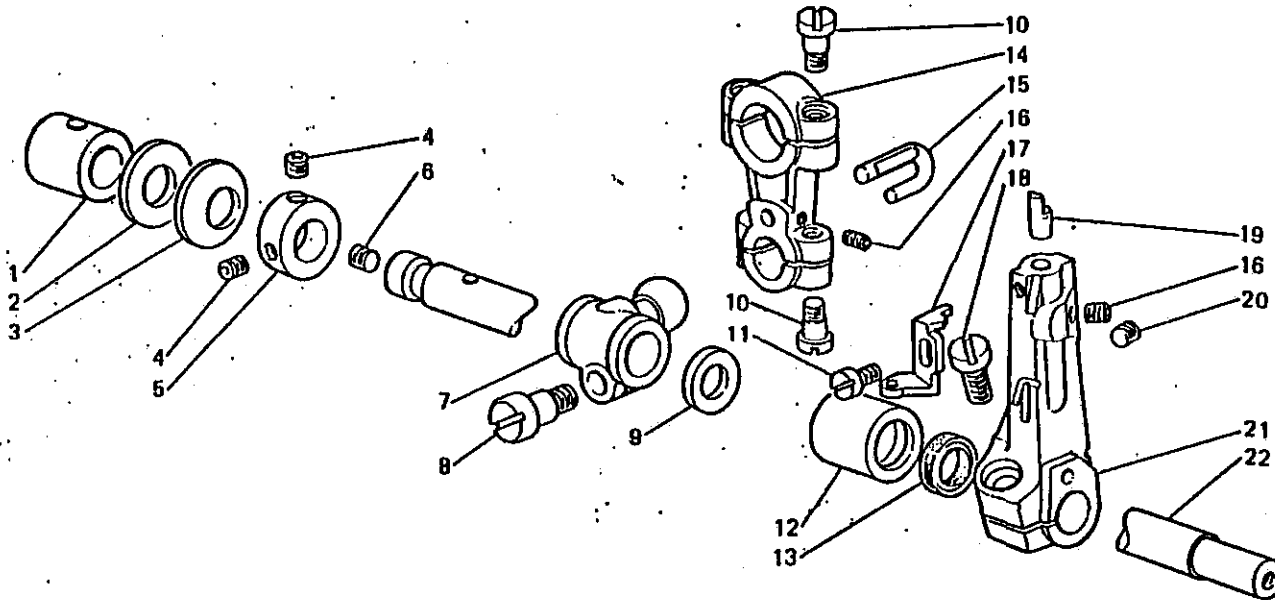

Fig. N.	Part. N. / Piece N.	Qt.
1	729012-2-00	2
2	701006-0-00	1
3	211295-0-00	1
4	209448-4-11	1
5	745815-2-00	1
6	209471-0-00	1
7	209442-0-00	2
8	745812-2-00	2
9	209445-2-02	1
10	209449-0-10	1
11	729031-2-00	1
12	211444-0-00	1
13	724430-2-00	4
14	728232-0-00	1
15	209376-0-00	4
16	703802-0-00	8
17	700605-0-00	8
18	704409-2-00	1
19	740087-2-00	1
20	700208-0-00	1
21	704314-2-00	2
22	701004-0-00	3
23	209447-0-02	1
24	350595-0-00	1
25	209449-0-00	1
26	202408-0-10	1
27	209378-0-00	1
28	741936-2-00	4
29	211427-3-00	1
30	211375-0-00	1
31	729033-2-00	1
32	209379-0-00	1
33	321055-0-00	4
34	207948-0-00	1
35	211381-0-00	1
36	211385-0-00	1
37	211386-2-00	1
38	741611-2-00	2
39	722063-2-00	2

# Rim<sup>®</sup> TAV. 5

PORTA CROCHET INFERIORE - LOWER LOOPER HOLDER - PORTE CROCHET INFER. - UNTERE GREIFERTRAEGER - SOPORTE CROCHET INFERIOR

Fig. N.	Part. N. Piese N.	Qt.
1	211209-0-01	1
2	705038-0-00	1
3	211281-0-00	1
4	729013-2-00	2
5	313060-2-00	1
6	727036-2-00	1
7	211224-2-00	1
8	201128-0-10	1
9	704895-0-00	1
10	722089-2-00	4
11	741415-2-00	1
12	211253-0-01	1
13	311168-0-00	1
14	209270-2-02	1
15	209272-0-00	1
16	745812-2-00	2
17	208015-0-00	1
18	721893-0-00	1
19	209259-0-00	1
20	745810-2-00	1
21	211250-2-00	1
22	211276-2-10	1



From the library of: Diamond Needle Corp

F29-FS-2CD-AM	211219-2-00
F29-FS-2CD-AN	211219-2-00
F29-FS-2CD-BA	211219-2-00
F29-FS-2CD-BB	211219-2-00
F29-FS-2MD-AP	211218-2-00
F29-FS-2MD-BC	211218-2-00

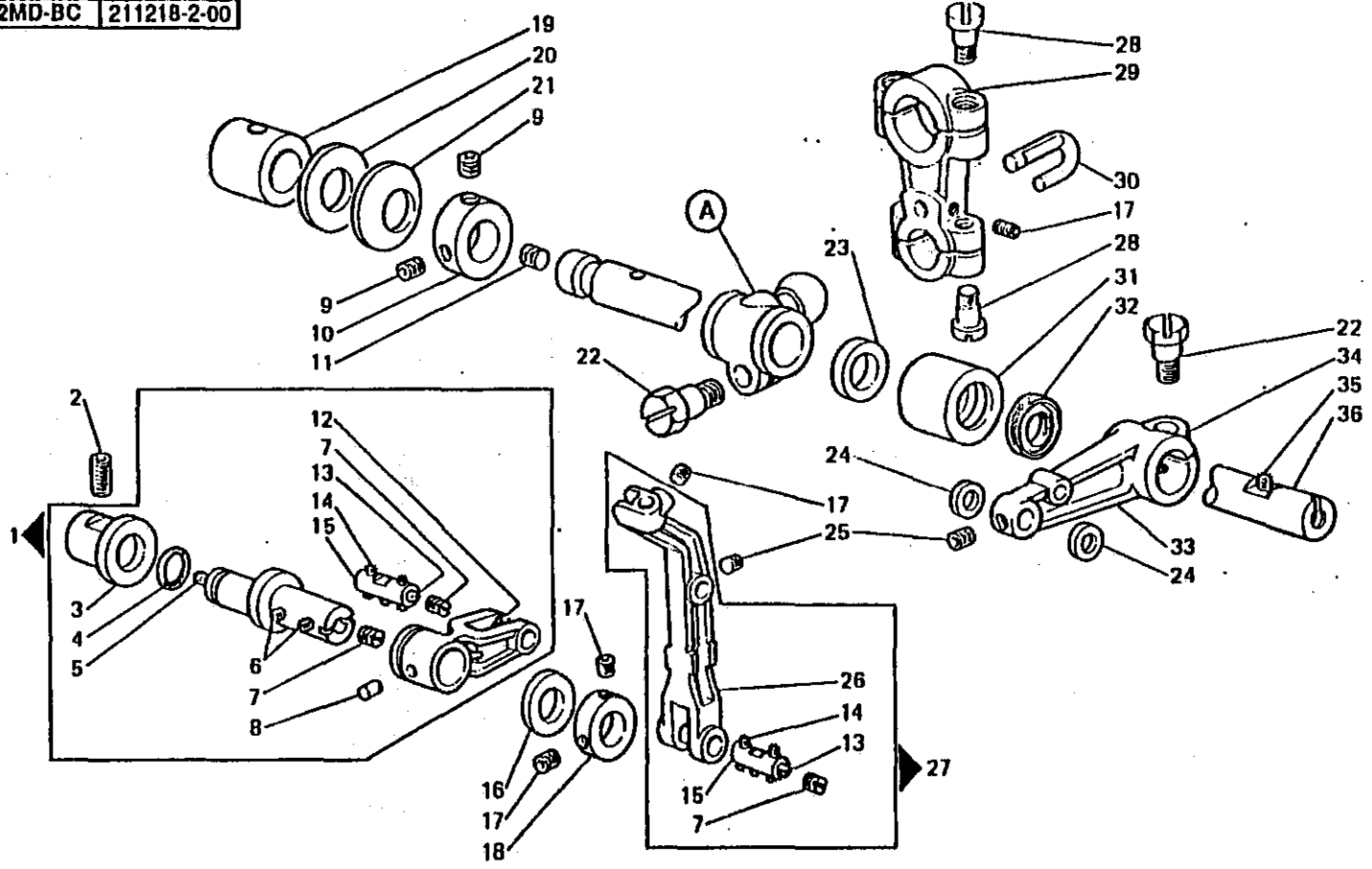

From the library of: Diamond Needle Corp

Fig. N.	Part. N. Piece N.	Qt.
1	211245-3-00	1
2	729064-2-00	1
3	211239-0-00	1
4	701005-0-00	1
5	778411-0-00	1
6	778204-0-00	4
7	745002-0-00	2
8	310724-0-00	1
9	729013-2-00	2
10	313060-2-00	1
11	727036-2-00	1
12	778503-0-00	1
13	778403-0-00	2
14	778202-0-00	10
15	211208-4-00	2
16	704873-0-00	1
17	745812-2-00	4
18	211241-2-00	1
19	211209-0-01	1
20	705036-0-00	1
21	211281-0-00	1
22	201128-0-10	2
23	704885-0-00	1
24	211213-0-00	2
25	745810-2-00	2
26	211202-0-00	1
27	211214-3-00	1
28	722089-2-00	4
29	209270-2-02	1
30	209272-0-00	1
31	211253-0-01	1
32	311166-0-00	1
33	211207-2-00	1
34	778419-0-00	1
35	778208-0-00	1
36	211280-4-10	1

# Rim<sup>®</sup> TAV. 7

PORTA CROCHET PUNTO SIC.-SAFETY STITCH LOOPER HOLDER-PORTE CROCHET POINT SUR.-GREIFERTRAEGER SICHERHEITSTICH-SOPORTE CROCHET PUNTO SEG.

Fig. N.	Part N. / Piece N.	Qt.
1	745815-2-00	2
2	209318-2-00	1
3	741558-0-00	2
4	207700-0-00	1
5	705008-0-00	1
6	740277-2-00	1
7	745812-2-00	8
8	741387-2-00	2
9	209309-2-01	1
10	209200-0-00	1
11	209297-0-00	1
12	209296-0-00	1
13	206606-0-00	3
14	209299-2-00	1
15	743243-2-00	2
16	733507-2-00	1
17	209293-2-01	1
18	704841-0-00	1
19	704860-0-00	1
20	211032-0-00	1
21	209308-0-00	1
22	730022-2-00	1
23	209313-2-00	1
24	722443-2-00	1
25	307651-0-00	1
26	211290-0-00	1
27	209258-0-00	1
28	745800-2-00	1
29	742232-2-00	1
30	209311-2-00	1
31	209280-0-00	1

F29-FS-2CD-AM  
F29-FS-2CD-AN  
F29-FS-2MD-AP

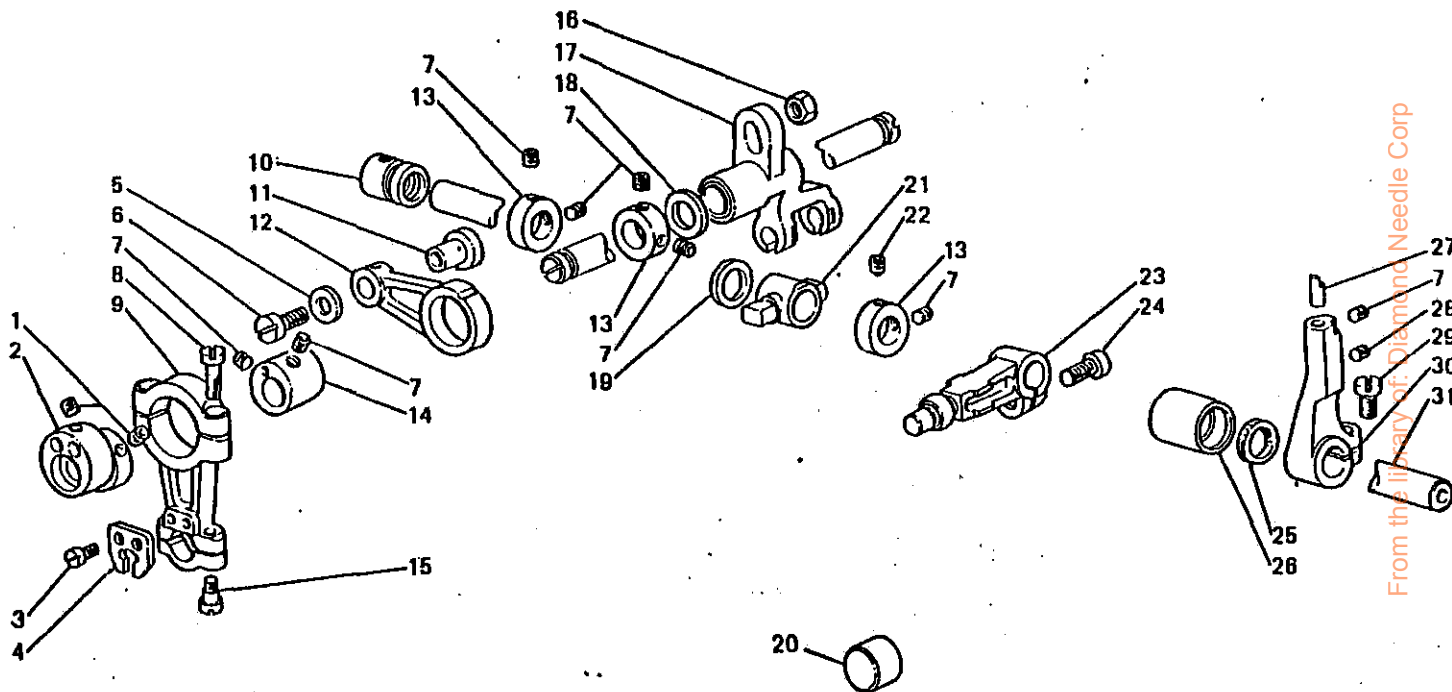

F29-FS-2CD-BA  
 F29-FS-2CD-BB  
 F29-FS-2MD-BC

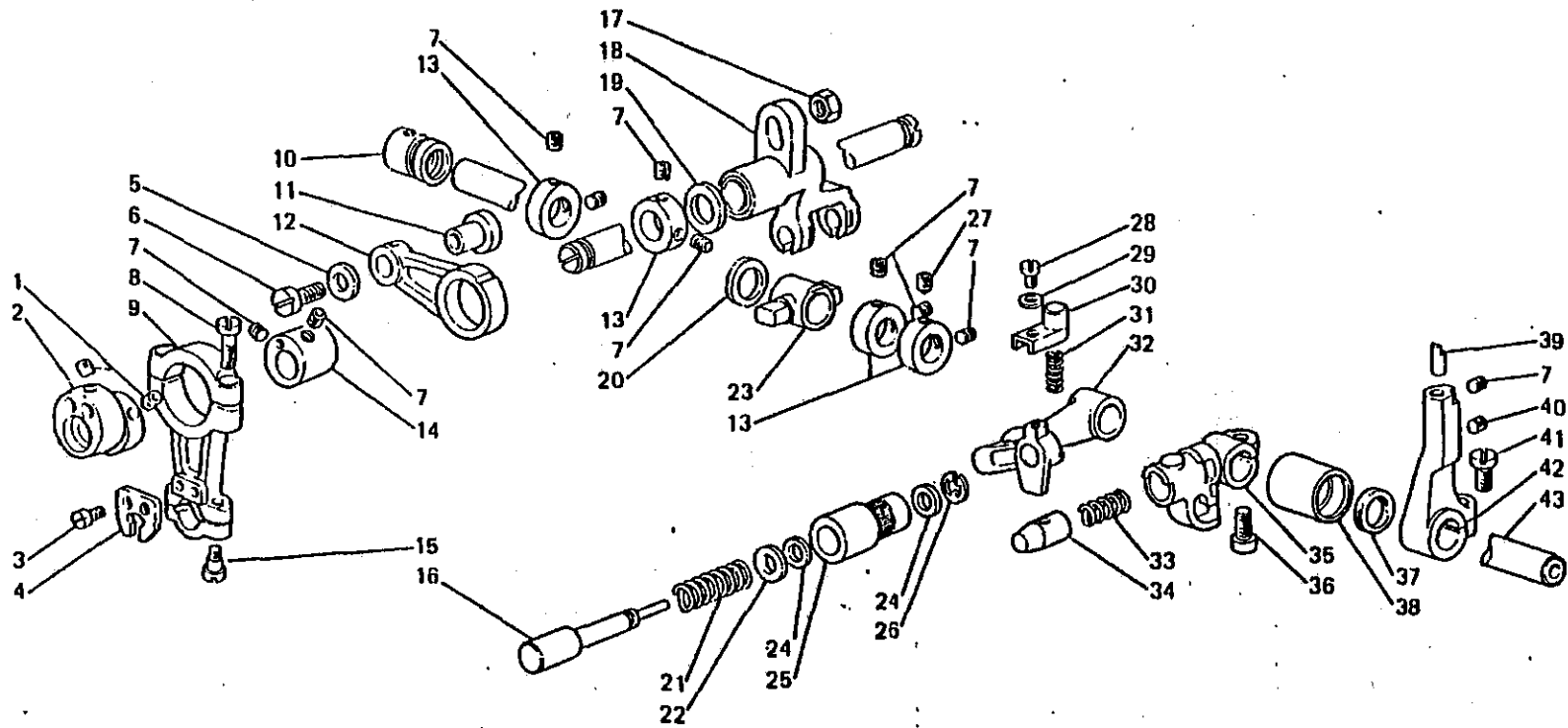
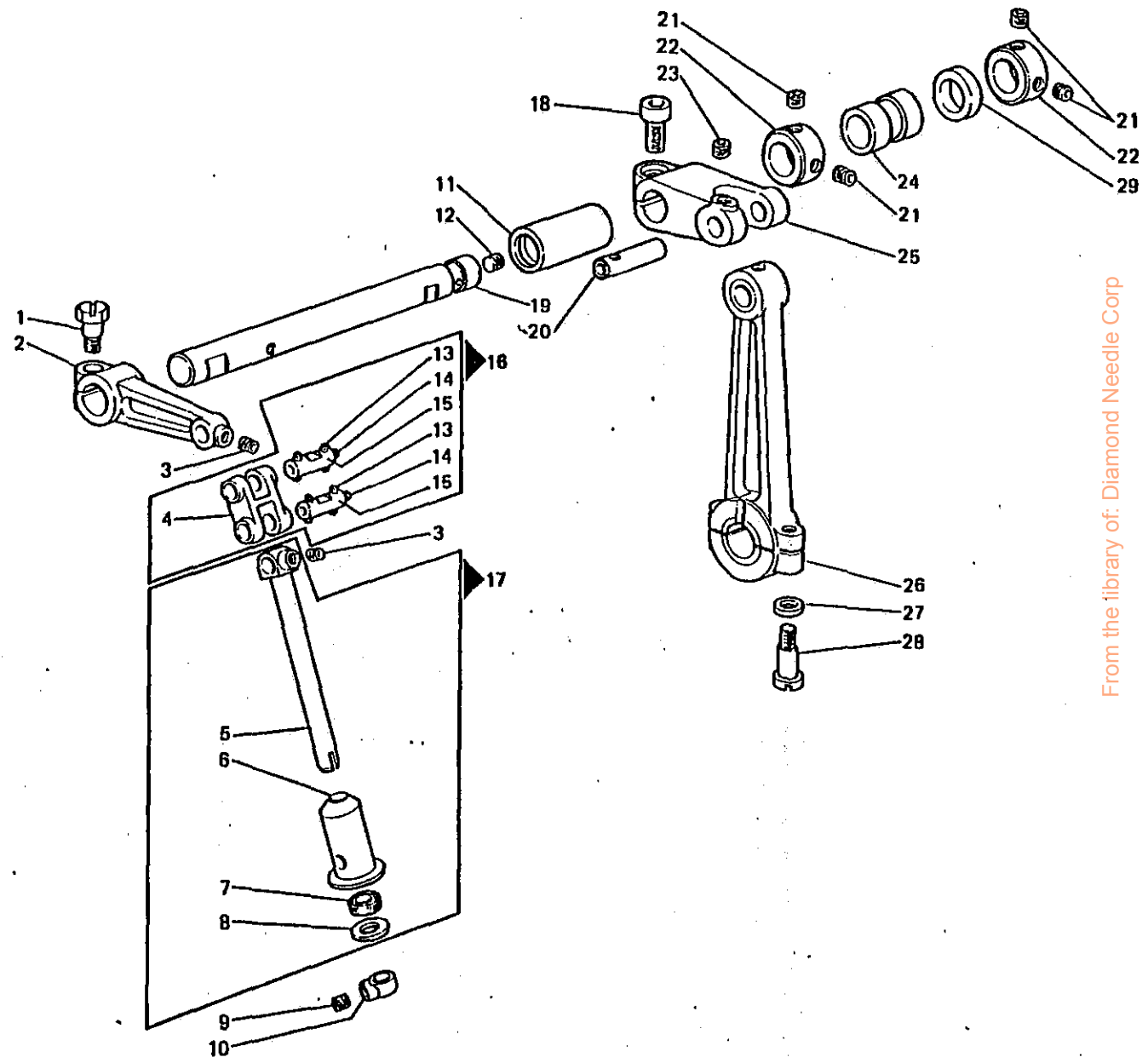

Fig. N.	Part N. Piece N.	Qt.
1	745815-2-00	2
2	209318-2-00	1
3	741558-0-00	2
4	207700-0-00	1
5	705008-0-00	1
6	740277-2-00	1
7	745812-2-00	10
8	741387-2-00	2
9	209309-2-01	1
10	209200-0-00	1
11	209297-0-00	1
12	209296-0-00	1
13	206606-0-00	4
14	209299-2-00	1
15	743243-2-00	2
16	209307-0-00	1
17	733507-2-00	1
18	209293-2-01	1
19	704841-0-00	1
20	704860-0-00	1
21	202408-0-10	1
22	704314-2-00	1
23	209308-0-00	1
24	701004-0-00	2
25	209303-0-00	1
26	700207-0-00	1
27	730022-2-00	1
28	722400-2-00	1
29	704302-4-00	1
30	209282-0-00	1
31	209283-0-00	1
32	209300-0-00	1
33	304195-0-10	1
34	304172-0-10	1
35	209301-2-00	1
36	722443-2-00	1
37	307651-0-00	1
38	211290-0-00	1
39	209258-0-00	1
40	745800-2-00	1
41	742232-2-00	1
42	209311-2-00	1
43	209280-0-00	1

# Rim<sup>®</sup> TAV. 9

## BARRA AGO - NEEDLE BAR - BARRE AIGUILLE - NADELSTANGE - BARRA DE AGUJA

Fig. N.	Part N. / Piece N.	Qt.
1	201128-0-10	1
2	211115-2-00	1
3	745810-2-00	2
4	211118-0-00	1
5	211114-0-00	1
6	211112-0-00	1
7	211110-0-00	1
8	211111-0-00	1
9	745812-2-00	1
10	211125-0-00	1
11	211119-0-00	1
12	727036-2-00	1
13	778204-0-00	8
14	778445-0-00	2
15	211129-4-00	2
16	211132-3-00	1
17	211109-4-00	1
18	744334-2-00	1
19	211113-0-00	1
20	209143-0-01	1
21	729013-2-00	4
22	313060-2-00	2
23	730022-2-00	1
24	211117-0-00	1
25	211142-2-01	1
26	211106-2-00	1
27	704213-2-00	2
28	722149-2-00	2
29	704853-0-00	1



From the library of: Diamond Needle Corp



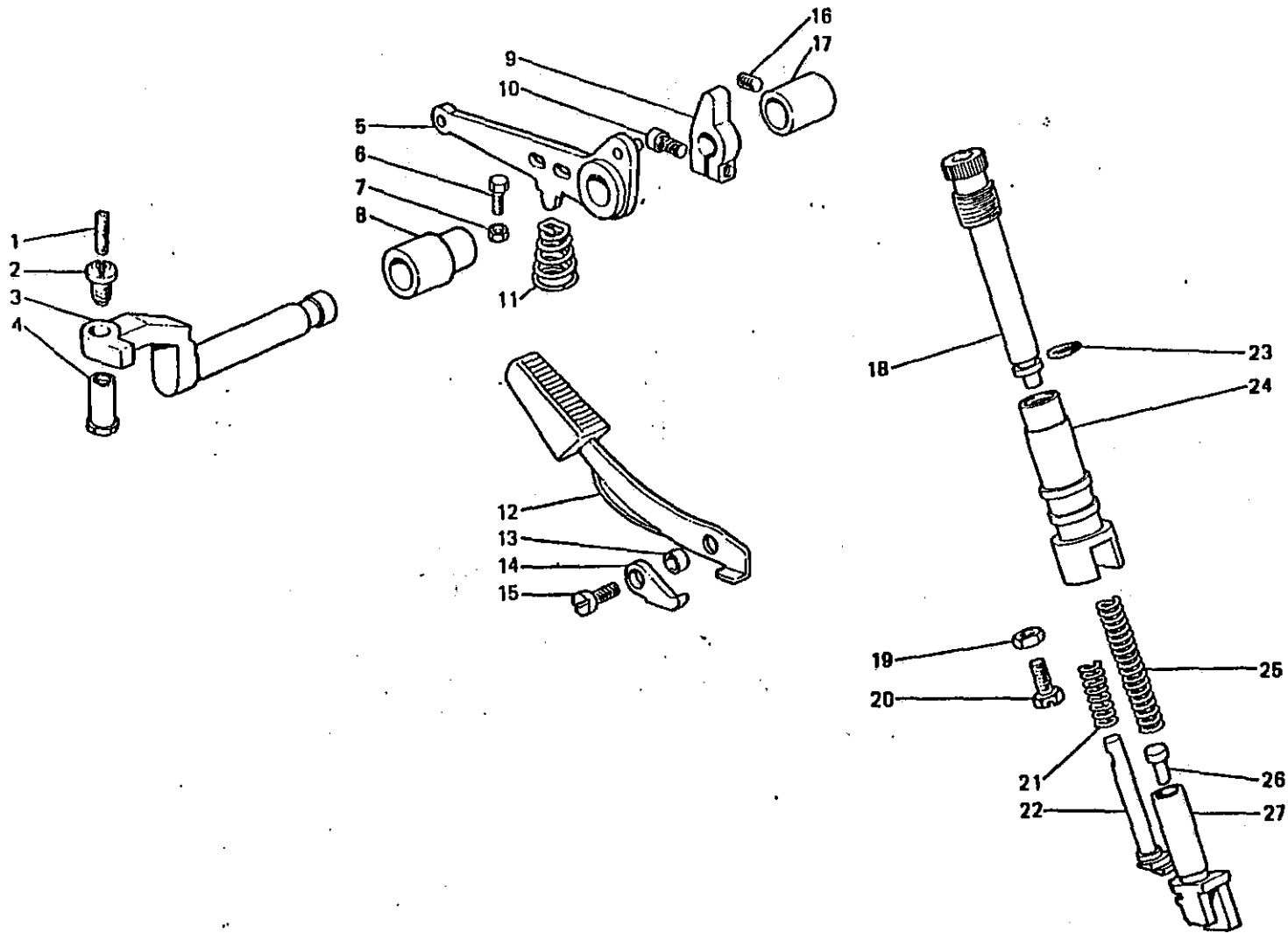
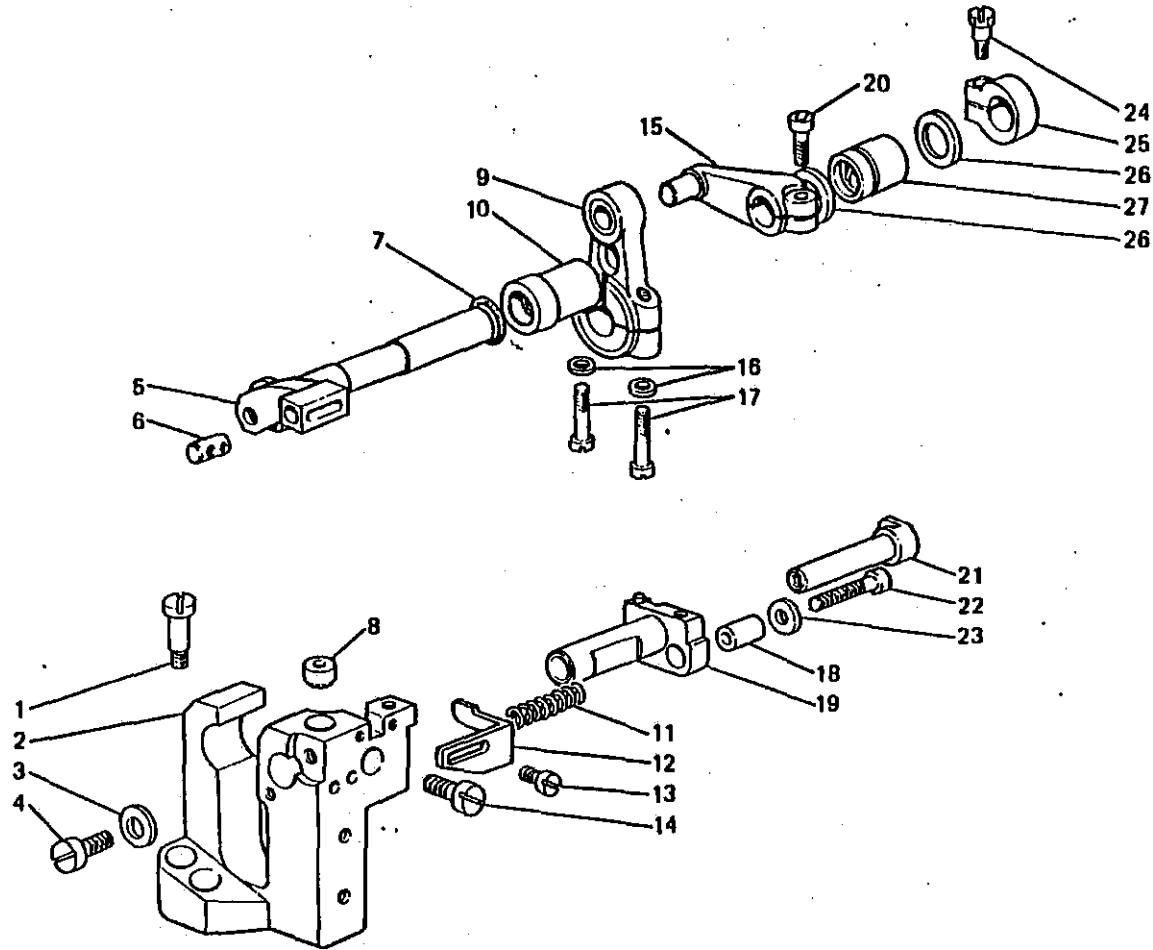

Fig. N.	Part N. Piece N.	Qt.
1	729031-2-00	1
2	202529-0-10	1
3	209500-0-10	1
4	206622-0-00	1
5	209501-0-11	1
6	740087-2-00	1
7	746021-2-00	1
8	209503-0-10	1
9	209522-2-00	1
10	740277-2-00	1
11	209521-0-00	1
12	209524-2-00	1
13	206637-0-00	1
14	206635-0-00	1
15	722421-2-00	1
16	745812-2-00	1
17	209504-0-10	1
18	211061-0-00	1
19	746007-2-00	1
20	202214-0-11	1
21	926273-0-01	1
22	207959-0-00	1
23	701008-0-00	1
24	211060-0-00	1
25	205021-0-10	1
26	207626-0-00	1
27	207625-0-00	1

From the library of: Diamond-Needle Corp

Fig. N.	Part. N. Piece N.	Qt.
1	209587-0-00	2
2	211031-2-00	1
3	704409-2-00	1
4	742457-2-00	1
5	209561-0-01	1
6	202130-0-11	1
7	701114-0-00	1
8	207958-0-01	1
9	209569-2-02	1
10	209588-0-11	1
11	202128-0-10	1
12	209577-0-01	1
13	721443-2-00	1
14	742758-0-00	1
15	209580-2-01	1
16	704213-2-00	2
17	722149-2-00	2
18	202129-0-10	1
19	209574-2-00	1
20	744334-2-00	1
21	209579-0-00	1
22	722471-2-00	1
23	704406-2-00	1
24	300482-0-10	1
25	209589-2-00	1
26	704863-0-00	2
27	209583-0-01	1



From the library of: Diamond Needle Corp

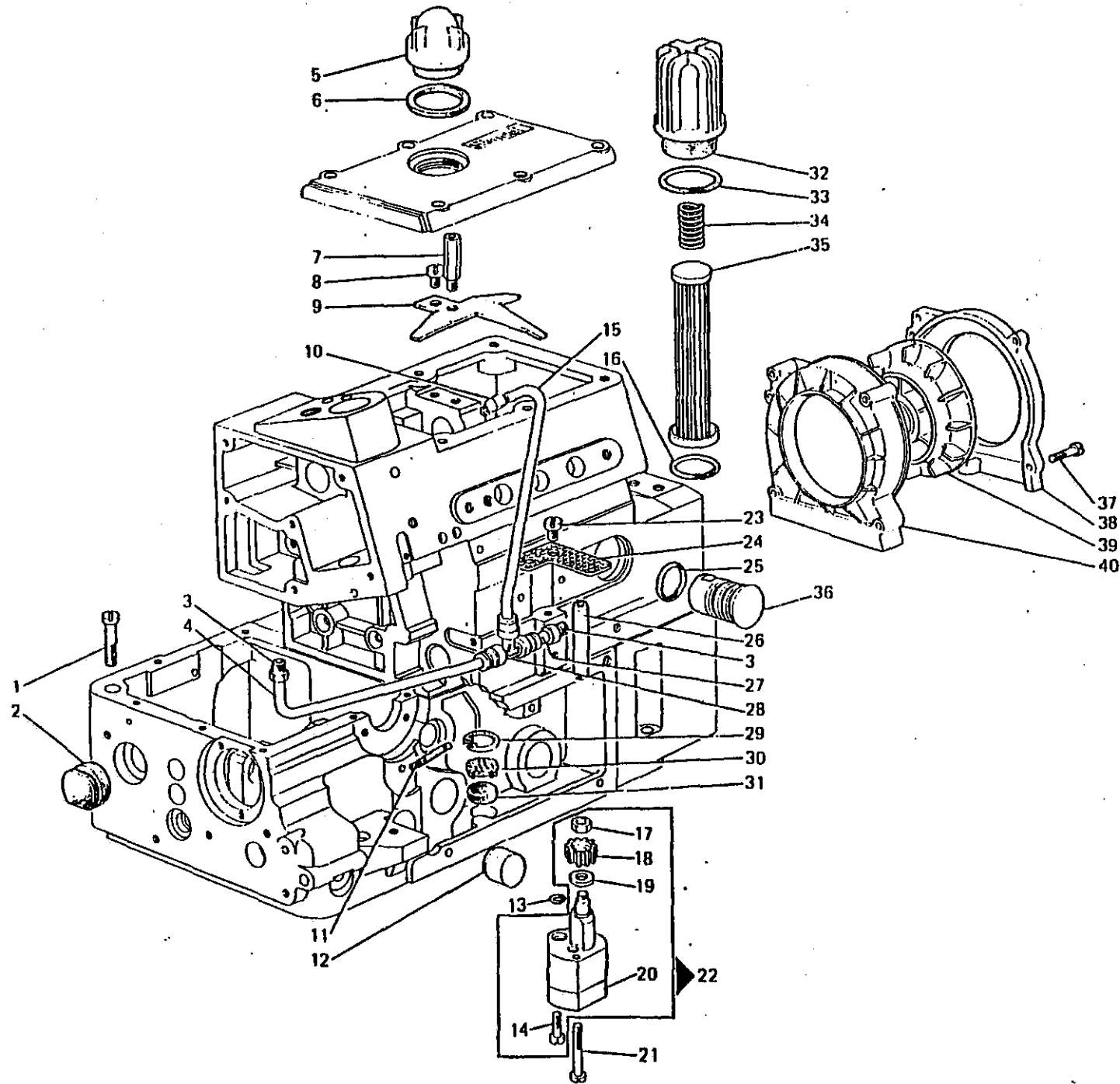

From the library of Diamond Needle Corp

Fig. N.	Part. N. Piece N.	Qt.
1	742086-2-00	5
2	211414-0-00	1
3	209541-0-00	2
4	790706-0-00	1
5	207973-0-01	1
6	705970-0-00	1
7	211063-0-00	1
8	722063-2-00	1
9	211062-0-00	1
10	926409-0-01	1
11	209383-0-00	1
12	209316-0-00	1
13	701004-0-00	1
14	741387-2-00	2
15	790716-0-00	1
16	701123-0-00	1
17	733507-2-00	1
18	206437-0-00	1
19	704813-0-00	1
20	206554-0-10	1
21	722511-2-00	2
22	206550-4-05	1
23	741925-2-00	1
24	209533-0-00	1
25	701031-0-00	1
26	209627-0-00	1
27	790700-0-00	1
28	941538-4-00	1
29	700116-0-00	1
30	315895-0-00	1
31	211128-0-00	1
32	211053-0-01	1
33	701042-0-00	1
34	922369-0-00	1
35	211052-0-00	1
36	211051-3-00	1
37	722143-2-00	4
38	206687-2-00	1
39	206690-2-00	1
40	206688-0-00	1

# Rim<sup>®</sup> TAV. 13

## BACINELLA OLIO - OIL BUMP - RESERVOIR HUILE - OELWANNE - TANQUE ACEITE

Fig. N.	Part. N. Piese N.	Qt.
1	701015-0-00	1
2	321206-0-00	1
3	209615-0-01	1
4	701006-0-00	1
5	720411-2-00	1
6	209624-0-11	1
7	206665-2-00	1
8	211013-0-00	1
9	209048-3-10	1
10	211675-0-00	1

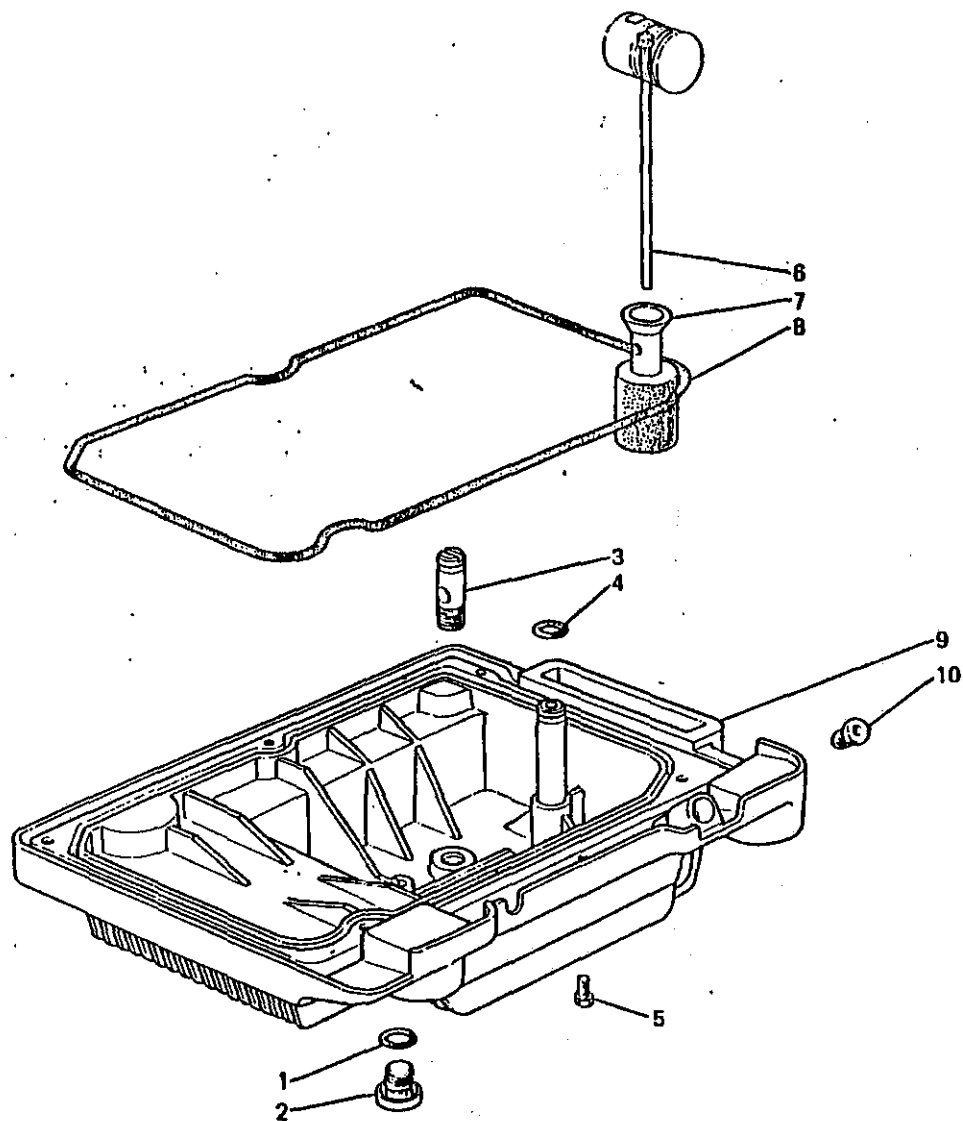

From the library of: Diamond Needle Corp

PIAZZAMENTO NORMALE  
 NORMAL SETTING  
 PLACEMENT NORMAL  
 NORMAL AUFSTELLUNG  
 COLOCACION NORMAL

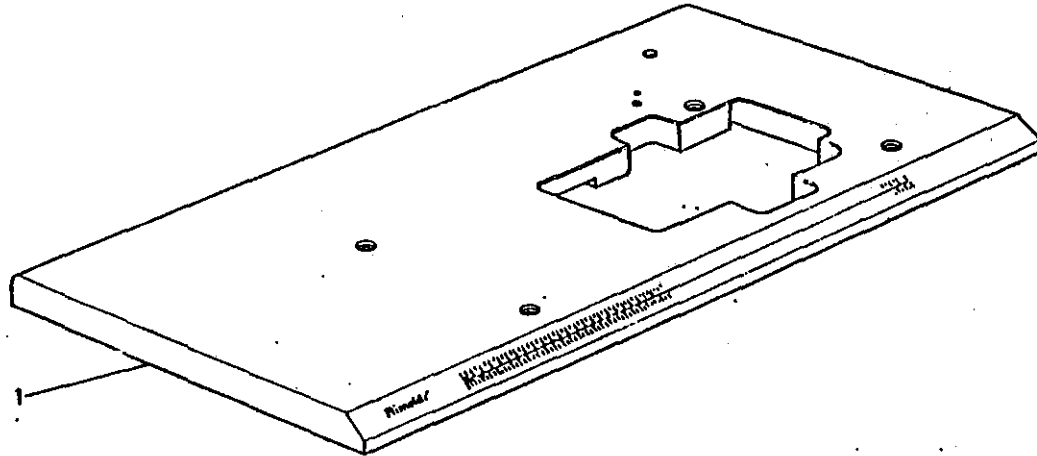

PIAZZAMENTO INCASSATO  
 SUBMERGED SETTING  
 PLACEMENT ENCASTRE  
 VERSENKT AUFSTELLUNG  
 COLOCACION SUMERGIDA

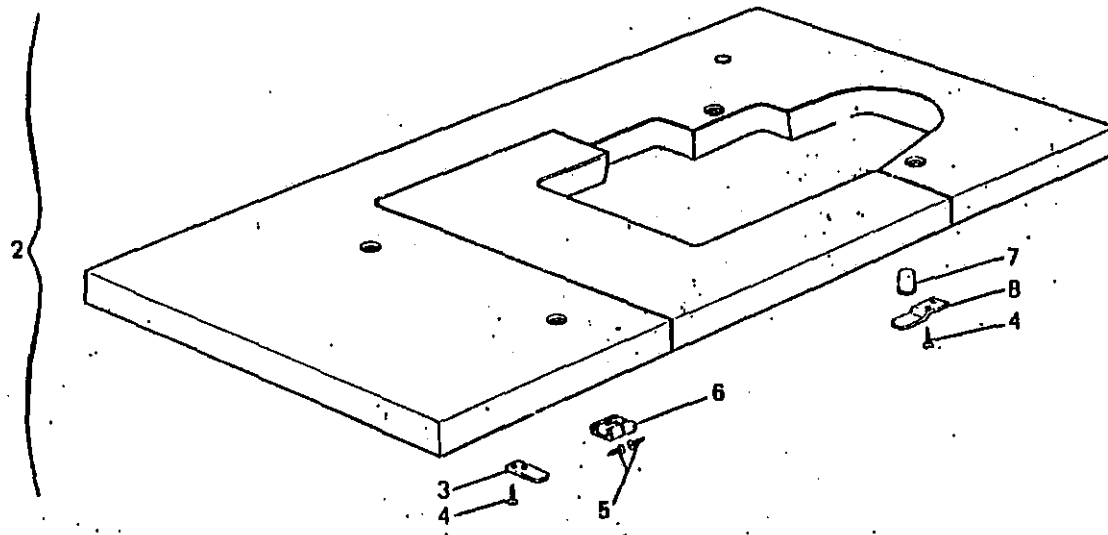

Fig. N.	Part. N. Piece N.	Qt.
1	901112-2-01	1
2	901113-4-01	1
3	900288-0-00	1
4	732425-0-00	4
5	732429-0-00	12
6	900285-0-00	3
7	900286-0-00	1
8	900249-0-00	1

From the library of: Diamond Needle Corp

# Rim<sup>®</sup> TAV. 15

PIAZZAMENTO NORMALE - NORMAL SETTING - PLACEMENT NORMAL - NORMAL AUFSTELLUNG - COLOCACION NORMAL

Fig. N.	Part. N. Piece N.	Qt.
1	722912-2-00	2
2	704346-2-00	14
3	901152-0-00	2
4	901101-0-00	8
5	901151-0-00	2
6	901102-0-00	4
7	733008-2-00	10
8	720546-2-00	2
9	700205-0-00	3
10	990314-0-10	1
11	990311-0-10	3
12	746402-2-00	2
13	990310-0-10	2
14	990312-0-10	1
15	900204-0-10	1
16	746409-2-00	1
17	704424-2-00	1
18	990988-0-00	4
19	900694-0-11	4
20	991349-0-00	1
21	990179-4-11	1
22	704013-2-00	4
23	722920-2-00	2
24	991750-0-01	1
25	901153-0-00	2
26	M488972020	
27	991187-0-01	1
28	900203-0-10	4

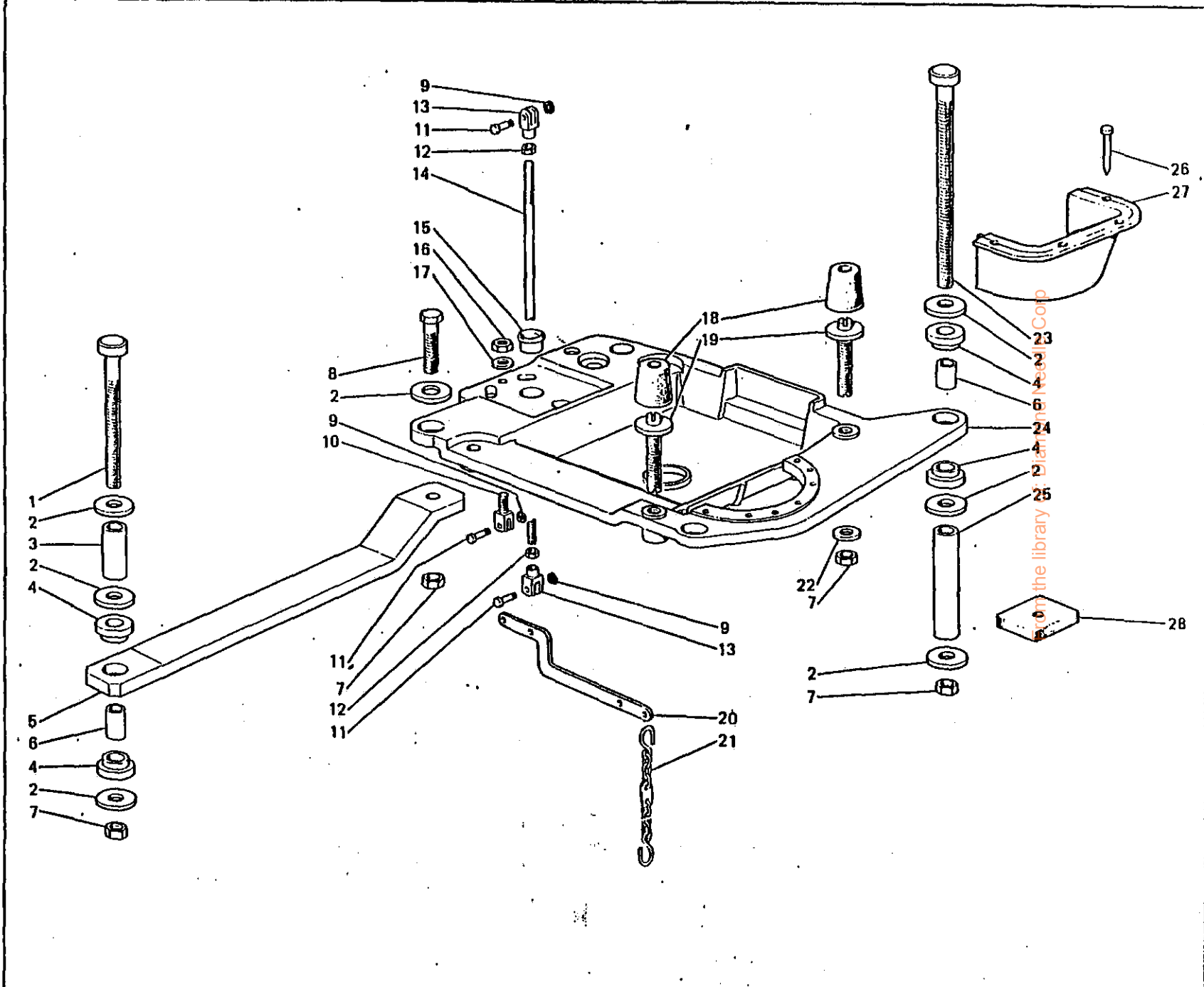

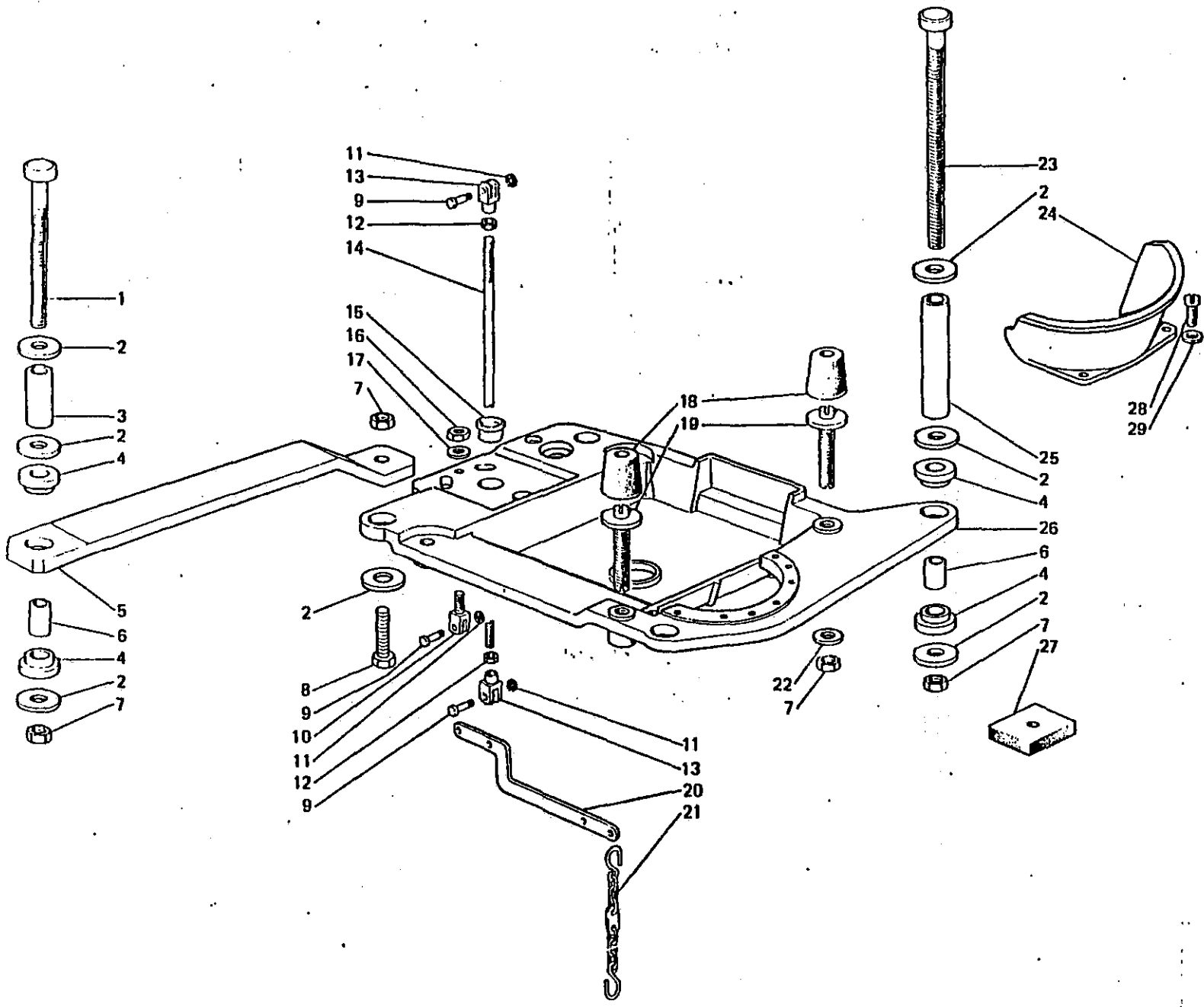

From the library of: Diamond Needle Corp

Fig. N.	Part. N. Piece N.	Qt.
1	722912-2-00	2
2	704346-2-00	14
3	901162-0-00	2
4	901101-0-00	8
5	901151-0-00	2
6	901102-0-00	4
7	733008-2-00	10
8	720546-2-00	2
9	990311-0-10	3
10	990314-0-10	1
11	700205-0-00	3
12	746402-2-00	2
13	990310-0-10	2
14	990312-0-10	1
15	900204-0-10	1
16	748409-2-00	1
17	704424-2-00	1
18	990988-0-00	4
19	900694-0-11	4
20	991349-0-00	1
21	990179-4-11	1
22	704013-2-00	4
23	722920-2-00	2
24	991188-0-02	1
25	901153-0-00	2
26	991750-0-01	1
27	900203-0-10	4
28	721475-2-00	2
29	704409-2-00	2

# Rim<sup>o</sup> TAV. 17

## PORTA BOBINE - BOBBIN CARRIER - PORTE BOBINES - GARNSTAENDER - PORTA CONOS

Fig. N.	Part. N. Piece N.	Qt.
1	991135-5-02	1
2	729034-2-00	3
3	991269-2-00	1
4	991137-2-02	2
5	991268-0-00	24
6	703005-0-00	5
7	722431-2-00	4
8	991134-0-00	6
9	991111-2-00	6
10	991179-0-01	6
11	991112-0-00	6
12	991199-0-00	3
13	733508-2-00	6
14	925433-0-00	6
15	733211-2-00	4
16	991172-0-00	3
17	991219-0-00	1
18	991143-0-10	2
19	991246-2-00	1
20	733505-2-00	2
21	991193-4-00	1
22	991264-2-00	1
23	991279-2-00	1
24	733806-0-00	1
25	991206-0-00	1
26	991267-0-00	1
27	704017-2-00	2
28	991383-0-10	1

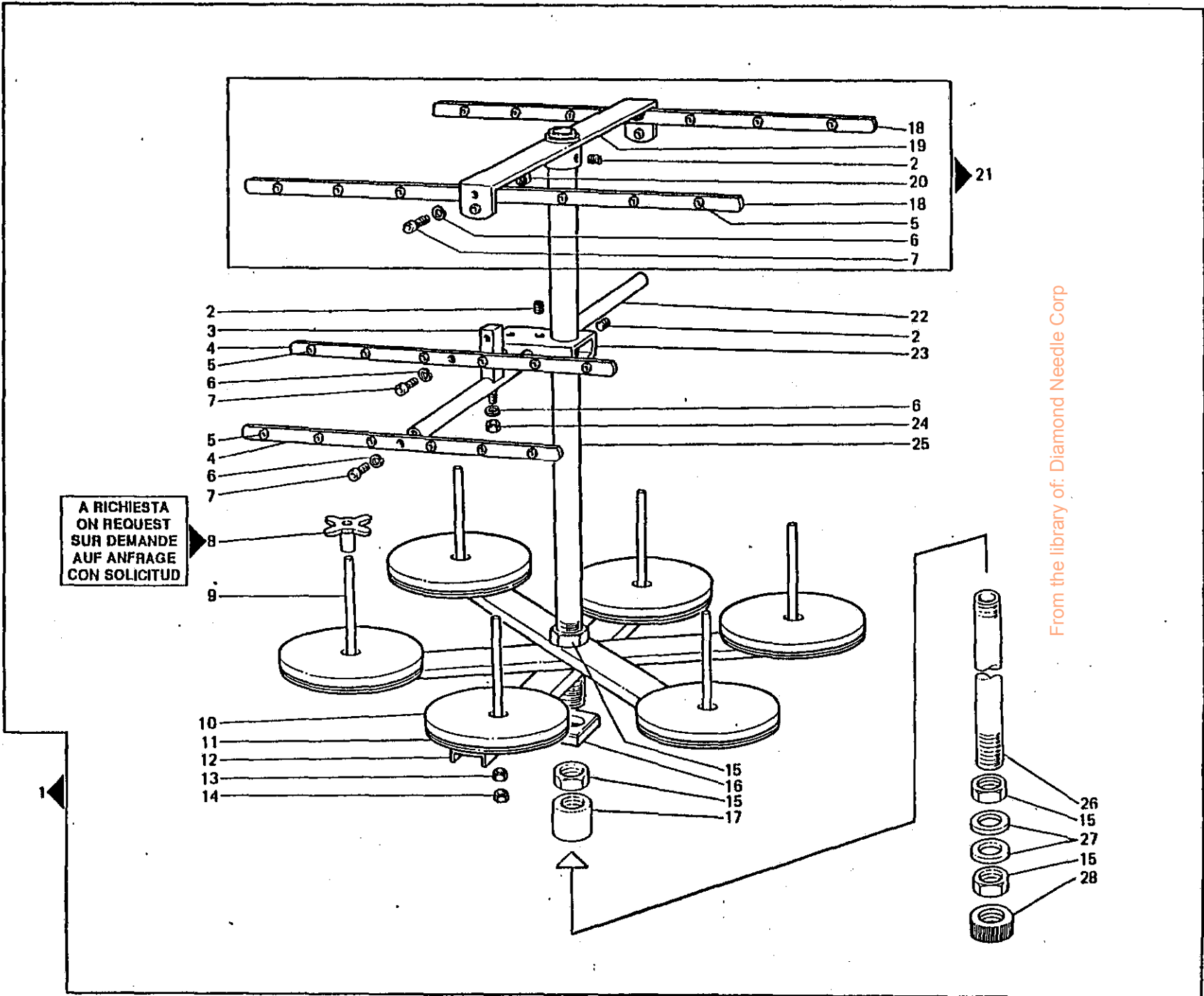

A RICHIESTA  
ON REQUEST  
SUR DEMANDE  
AUF ANFRAGE  
CON SOLICITUD

From the library of: Diamond Needle Corp



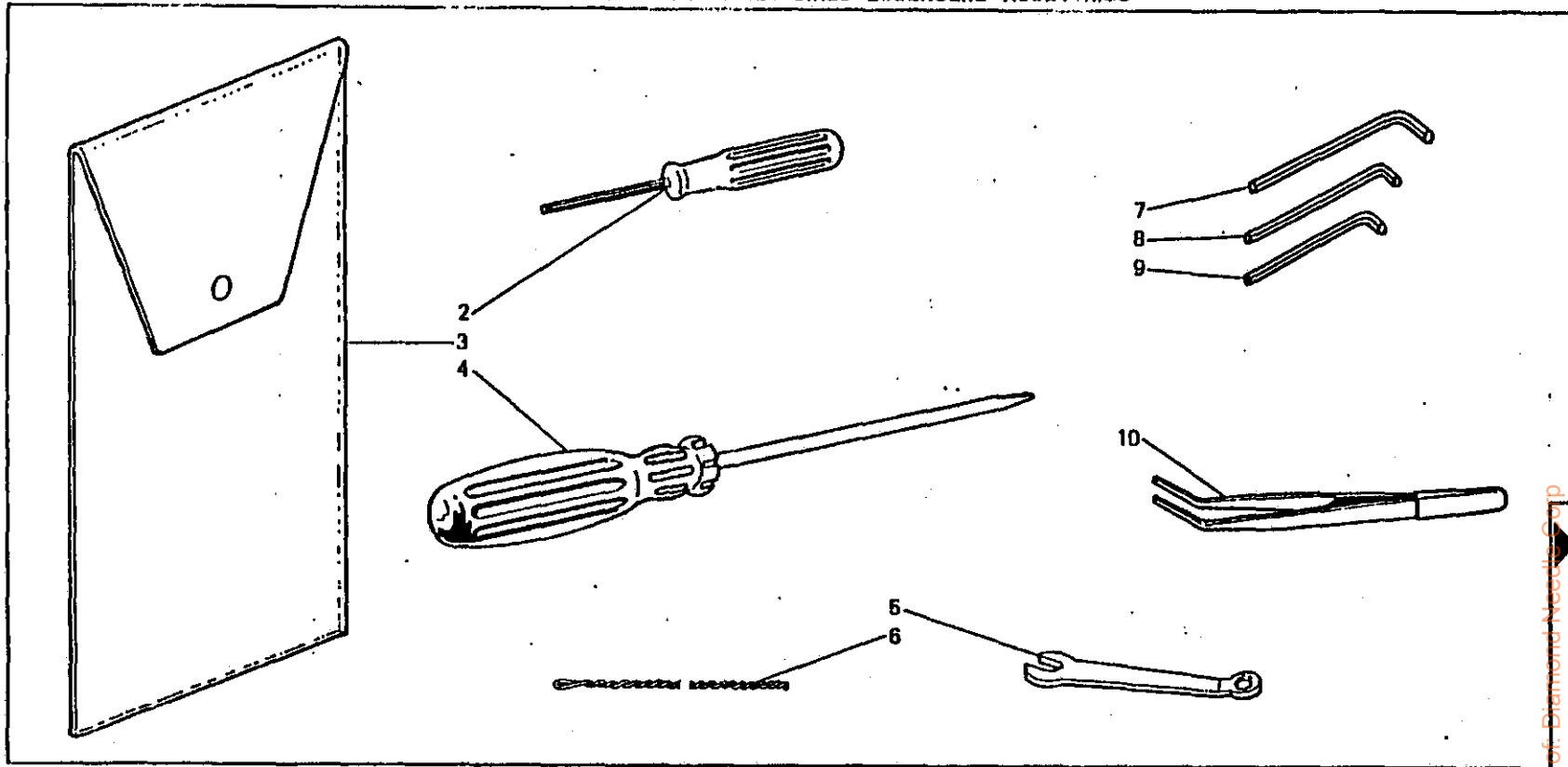

From the library of: Diamond Needle Corp

Fig. N.	Part N. Piece N.	Qt.
1	991466-4-00	1
2	990474-0-11	1
3	991415-0-00	1
4	990723-0-00	1
5	991650-0-00	1
6	990223-0-02	1
7	990639-0-10	1
8	990685-0-10	1
9	990325-0-10	1
10	990176-0-10	1
11	990979-0-00	1
12	991512-0-00	1
13	722063-2-00	2
14	209020-0-00	1

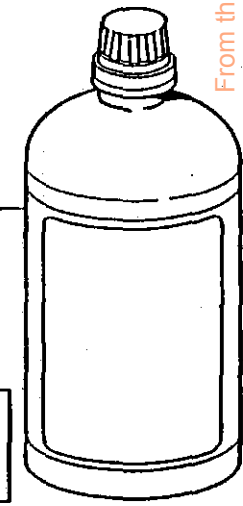
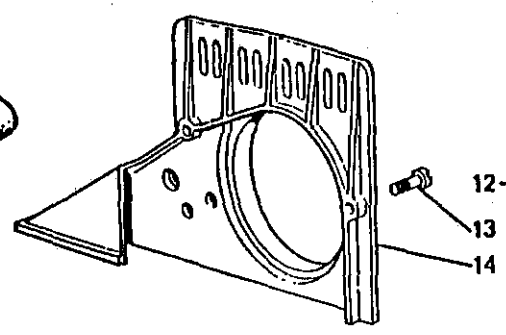
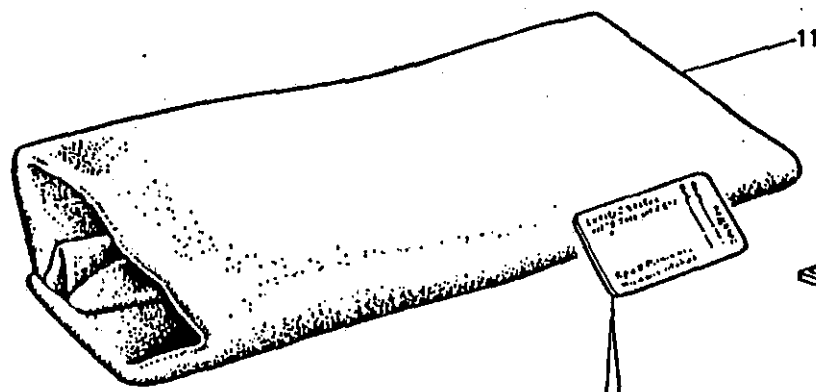

Per l'ordinazione della bustina aghi citare lo stesso simbolo dell'ago montato sulla testa.

To order packet of needles please specify symbol of needle fitted on machine.

Pour commander un sachet d'aiguilles donner le symbol de l'aiguille montee sur la tête.

Um die Nadelnpackung zu bestellen bitte das gleiche Nadelsymbol wie die an Naehekopf umgebautete Nadel zu geben.

Para el pedido de un paquete de agujas, citar el mismo simbolo de la aguja montada en el cabezal.

From the library of: Diamond Needle Corp

GRUPPI DI COMPOSIZIONE - COMPOSITION KITS - GROUPES DE KIT - KIT GRUPPEN - GRUPOS DE COMPOSICION

TENSIONI  
TENSIONS  
TENSIONS  
SPANNUNG  
TENDEHILOS

WFS-6C

From the library of: Dainippon Ink & Chemicals Corp

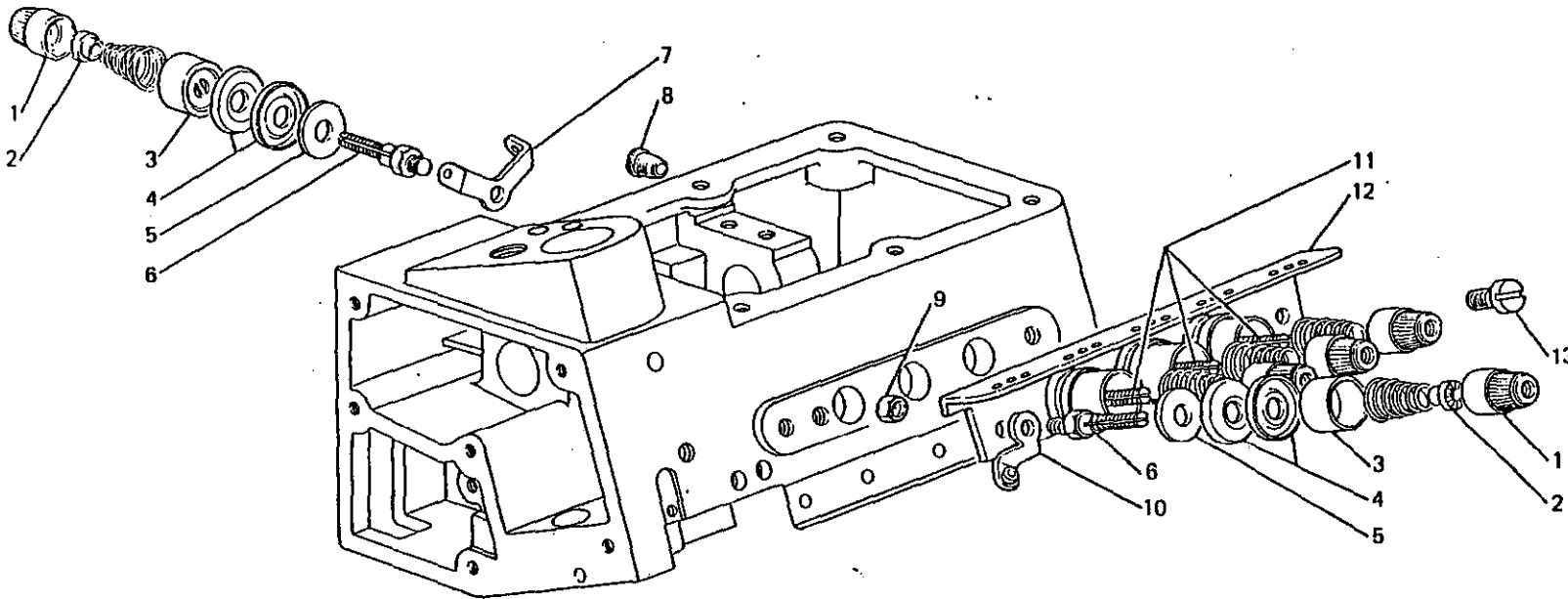

Fig. N.	Part. N. Piece N.	Qt.
1	202558-0-11	5
2	202229-0-11	5
3	202556-0-01	5
4	300218-0-10	10
5	206754-0-00	5
6	208169-0-01	2
7	308503-0-01	1
8	207893-0-00	1
9	746406-2-00	3
10	206713-2-00	1
11	206747-0-02	3
12	209753-0-00	1
13	202397-0-10	1

From the library of: Diamond Testers Corp

GRUPPI DI COMPOSIZIONE - COMPOSITION KITS - GROUPES DE KIT - KIT GRUPPEN - GRUPOS DE COMPOSICION

ATTREZZATURE VARIE  
VARIOUS EQUIPMENT  
EQUIPEMENT DIVERS  
ANDERE BAUTEILE  
EQUIPOS VARIOS

WFS-65

From the library of: Diamond Video Corp

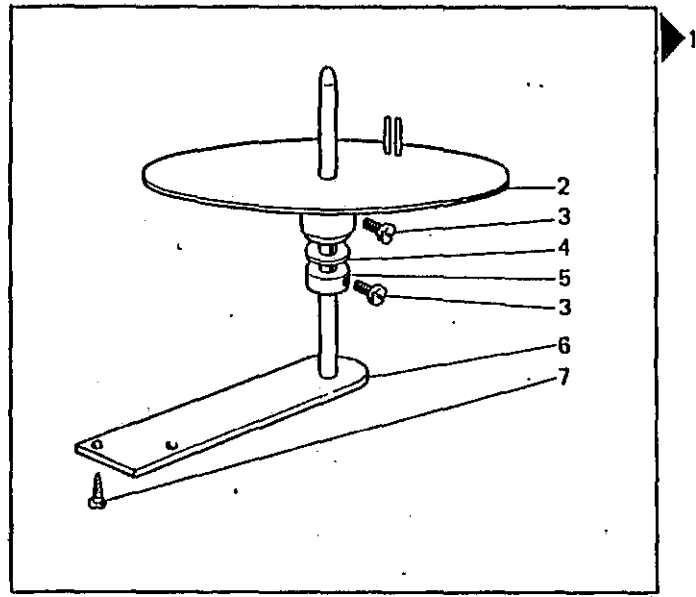

From the library of Diamond Needle Corp.

Fig. N.	Part N. Piece N.	Qt.
1	991589-4-00	1
2	991590-2-00	1
3	723266-2-00	2
4	311408-0-00	1
5	991581-2-00	1
6	991321-2-00	1
7	731107-2-00	2

GRUPPI DI COMPOSIZIONE - COMPOSITION KITS - GROUPES DE KIT - KIT GRUPPEN - GRUPOS DE COMPOSICION

GRUPPO COMANDO  
CONTROL ASSEMBLY  
GROUPE COMMANDE  
WALZENSTEUERUNG  
GRUPO MANDO

From the library of: *Defense* Corp

WFS-66

GINOCCHIELLO PER PIAZZAMENTO NORMALE  
 KNEE-PRESS FOR NORMAL SETTING  
 GENOILLERE POUR PLACEMENT NORMAL  
 KNEHEBEL FUER NORMAL AUFSTELLUNG  
 RODILLERA PARA COLOCACION NORMAL

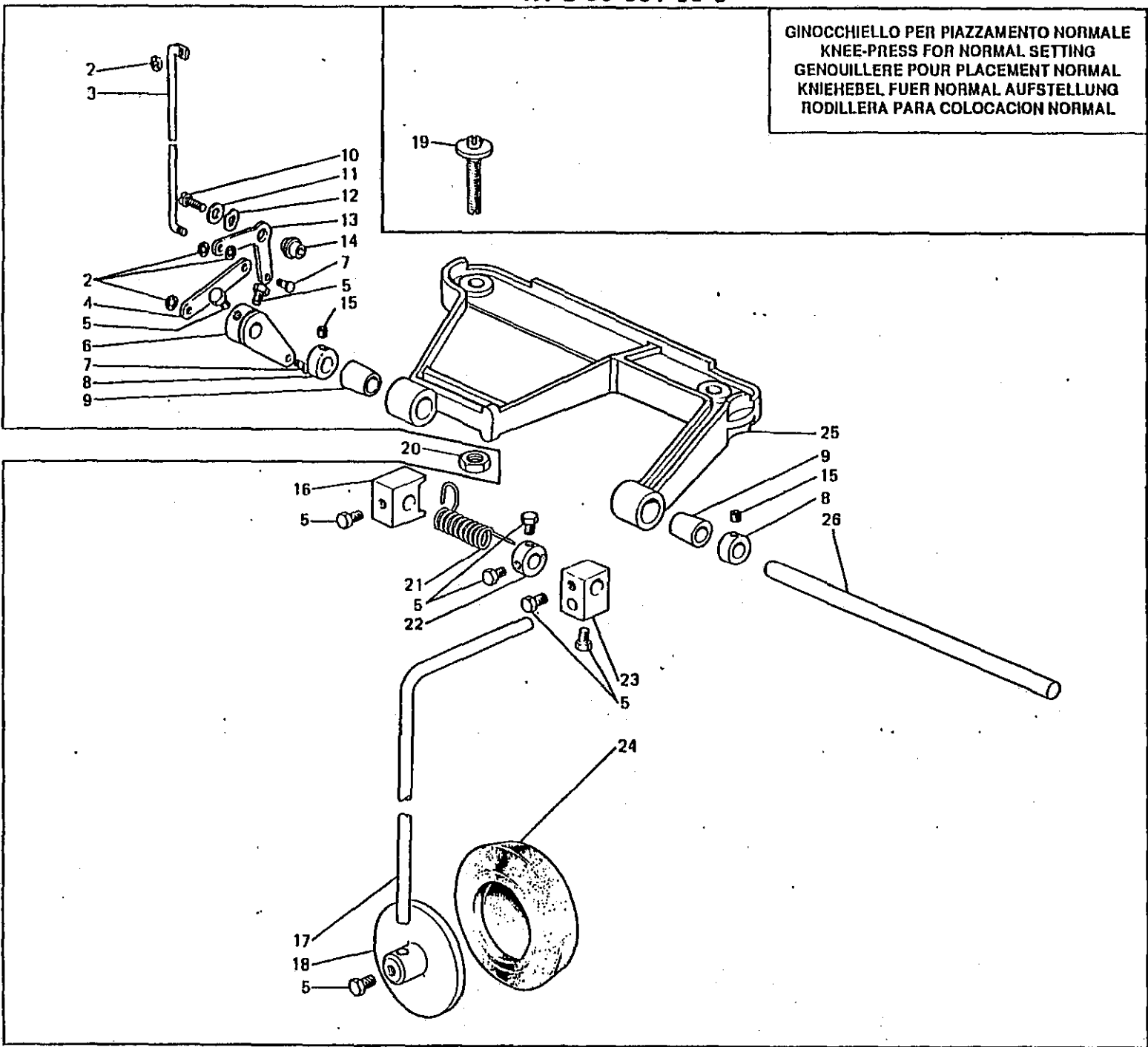
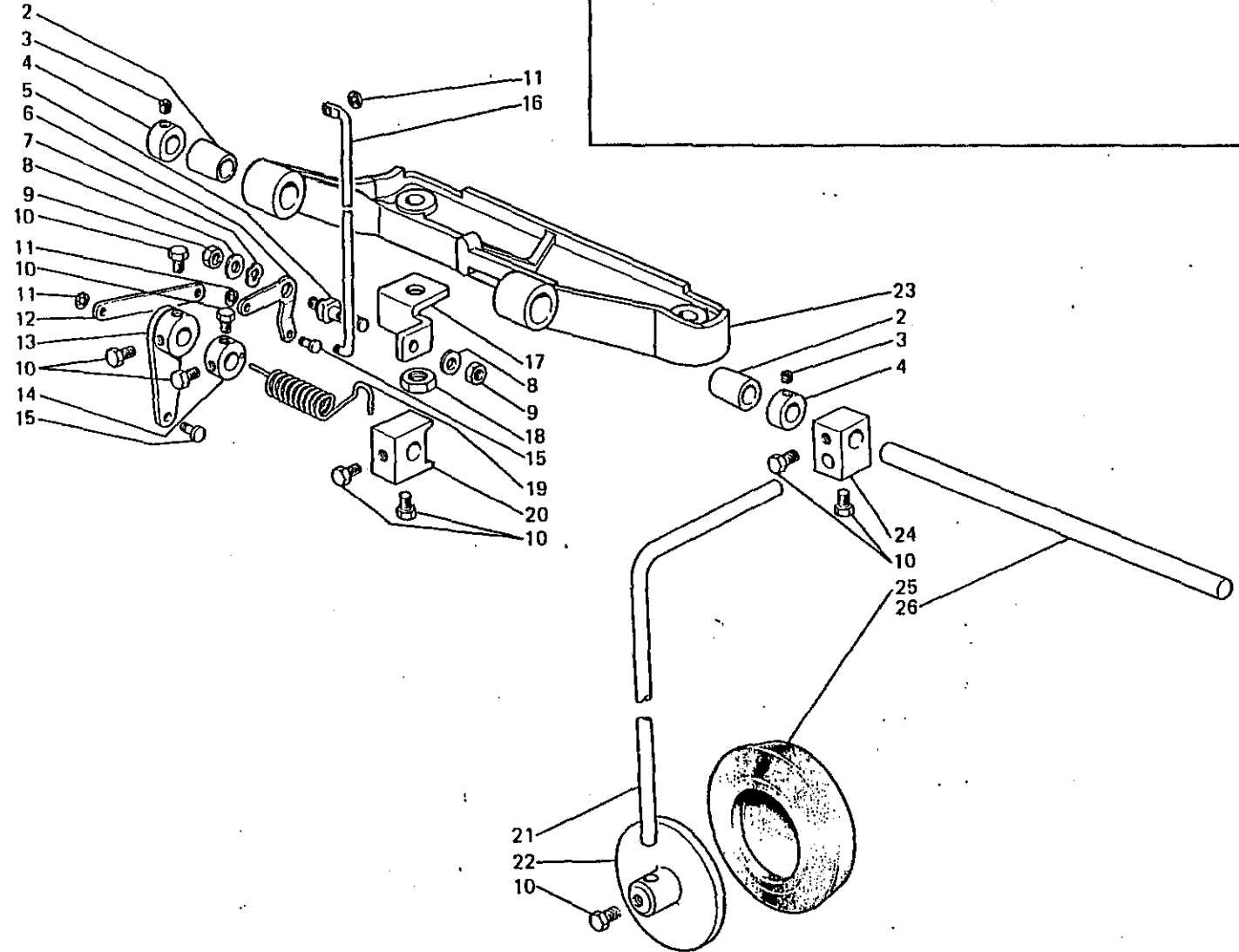

Fig. N.	Part N. Pieco N.	Qt.
1	920177-4-00	1
2	700206-0-00	4
3	920626-0-00	1
4	920625-0-00	1
5	740035-0-00	9
6	920623-2-00	1
7	920178-0-00	2
8	920242-2-00	2
9	920231-0-00	2
10	742068-2-00	1
11	704218-2-00	1
12	208220-0-00	1
13	920624-0-00	1
14	920621-0-00	1
15	729013-2-00	2
16	920128-0-00	1
17	920490-0-10	1
18	920105-0-10	1
19	901265-0-00	1
20	733008-2-00	2
21	920235-0-00	1
22	920114-0-10	1
23	920103-0-11	1
24	920113-0-11	1
25	920627-0-00	1
26	920230-0-00	1

From the library of: Diamond Needle Corp



GINOCCHIELLO PER PIAZZAMENTO INCASSATO  
 KNEE-PRESS FOR SUBMERGED SETTING  
 GENUILLERE POUR PLACEMENT ENCASTRE  
 KNIHEBEL FUER VERSENKT AUFSTELLUNG  
 RODILLERA PARA COLOCACION SUMERGIDA



Rim®

Fig. N.	Part. N. Piece N.	Qt.
1	920176-4-00	1
2	920231-0-00	2
3	729013-2-00	2
4	920242-2-00	2
5	920957-0-00	1
6	920956-0-00	1
7	208220-0-00	1
8	704216-2-00	2
9	733507-2-00	2
10	740035-0-00	9
11	700206-0-00	4
12	920179-0-00	1
13	920960-2-00	1
14	920114-0-10	1
15	920178-0-00	2
16	920961-0-00	1
17	920958-0-00	1
18	733008-2-00	1
19	920106-0-10	1
20	920128-0-00	1
21	920490-0-10	1
22	920105-0-10	1
23	920241-0-01	1
24	920103-0-11	1
25	920113-0-11	1
26	920230-0-00	1

From the library of: Diamond Needle Corp

GRUPPI DI COMPOSIZIONE - COMPOSITION KITS - GROUPES DE KIT - KIT GRUPPEN - GRUPOS DE COMPOSICION

CARTER  
COVER  
CARTER  
CARTER  
TAPADERAS

WFS-68

From the Library of: Diamond Speed Corp

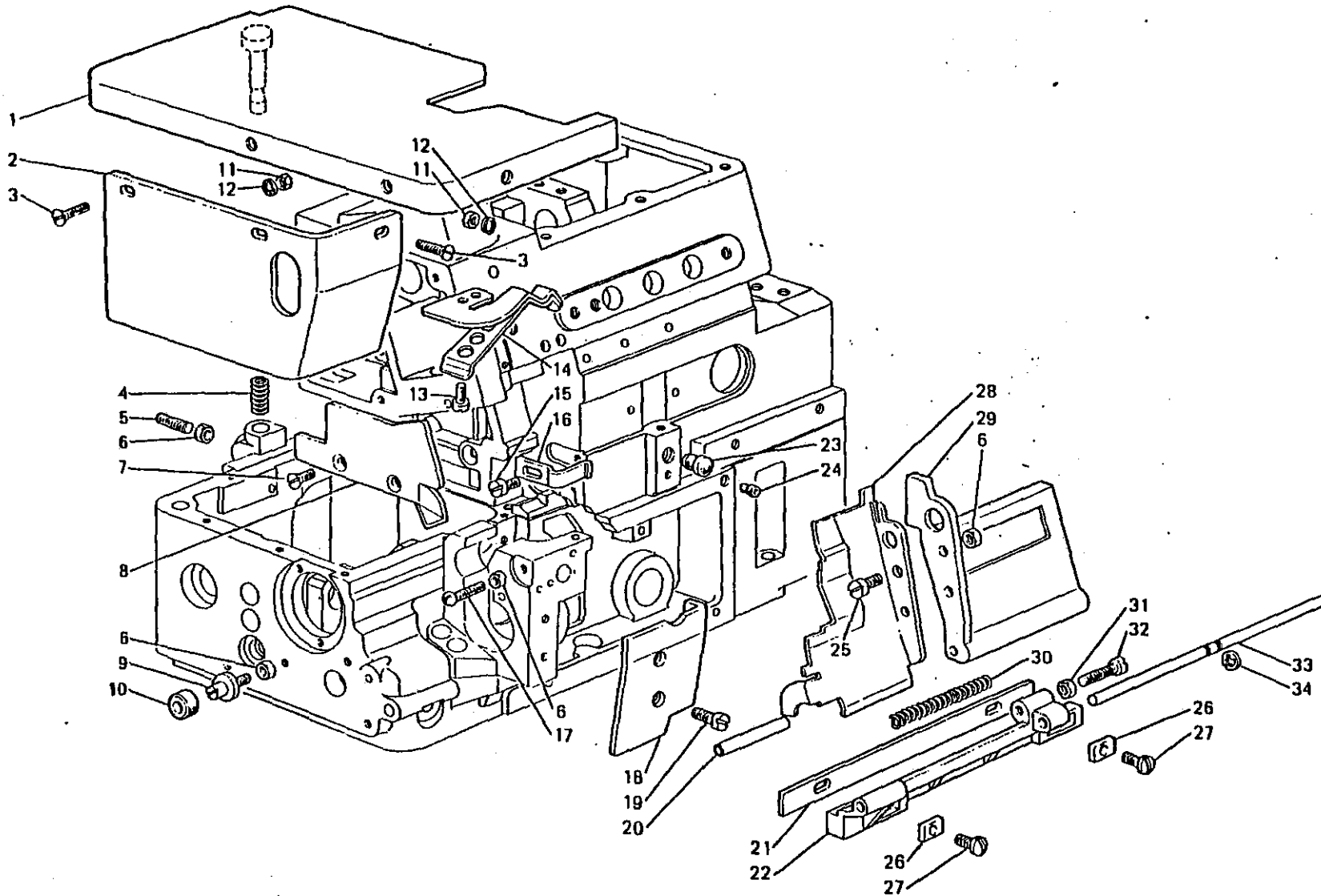
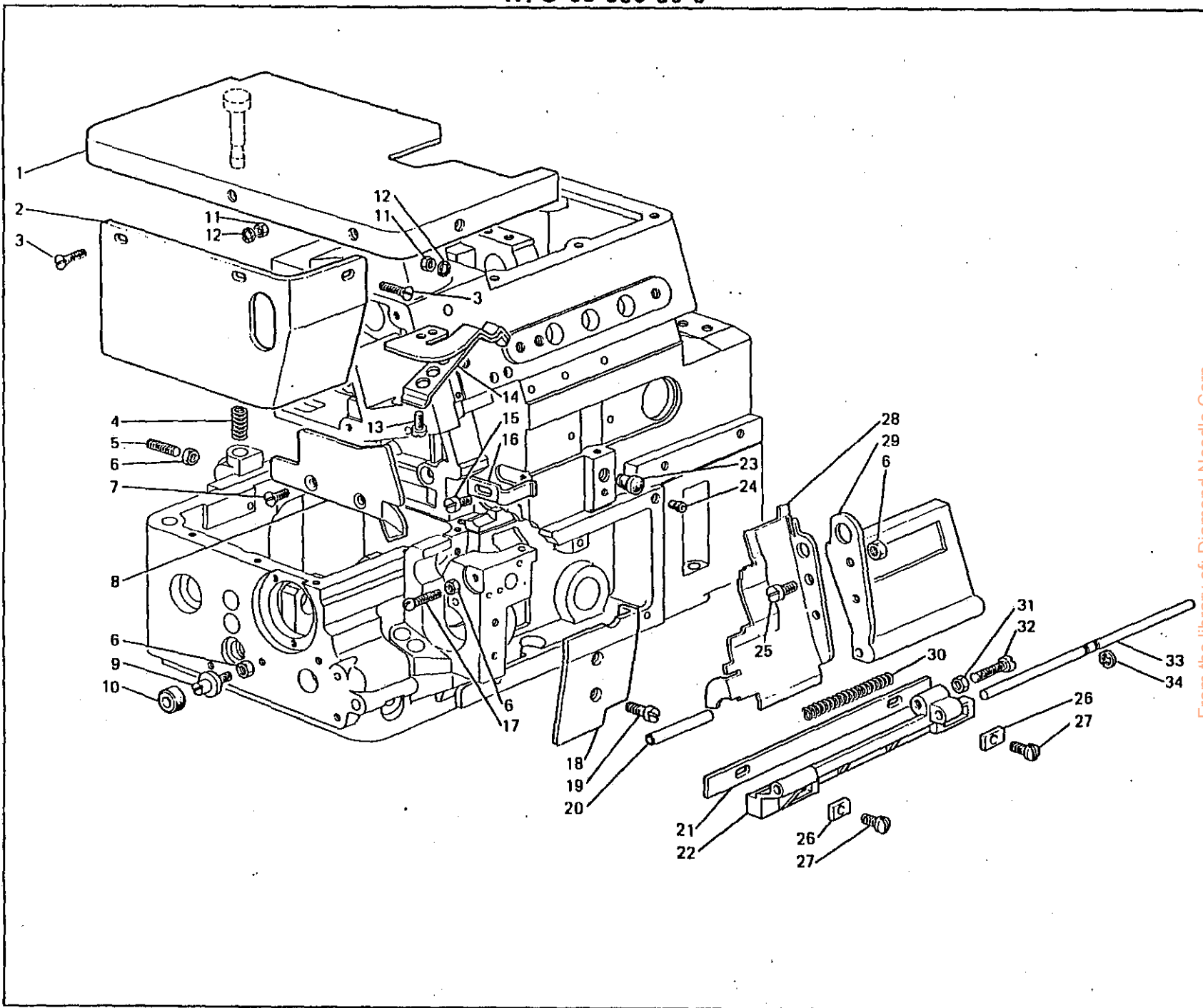

Fig. N.	Part N. Piece N.	Qt.
1	211704-2-00	1
2	211689-0-00	1
3	744651-0-00	3
4	211410-0-00	1
5	211409-0-00	1
6	746007-2-00	5
7	744730-2-00	2
8	211714-0-00	1
9	211694-0-00	1
10	211028-0-00	1
11	746003-0-00	3
12	703203-0-00	3
13	721423-0-00	2
14	211703-2-00	1
15	721454-2-00	1
16	211686-0-00	1
17	211715-0-00	1
18	211692-0-00	1
19	741967-2-00	2
20	211682-0-00	1
21	211539-0-00	1
22	211582-0-00	1
23	202398-0-10	1
24	207856-0-00	1
25	200356-0-10	2
26	209720-0-00	2
27	722441-2-00	2
28	209685-0-00	1
29	211681-0-00	1
30	209683-0-00	1
31	733806-2-00	1
32	722143-2-00	1
33	211583-0-01	1
34	700207-0-00	1

From the library of Diamond Needle Corp.



From the library of: Diamond Needle Corp.

Fig. N.	Part. N. Place N.	Qt.
1	211704-2-00	1
2	211689-0-00	1
3	744651-0-00	3
4	211410-0-00	1
5	211409-0-00	1
6	746007-2-00	5
7	744730-2-00	2
8	211714-0-00	1
9	211694-0-00	1
10	211028-0-00	1
11	746003-0-00	3
12	703203-0-00	3
13	721423-0-00	2
14	211703-2-00	1
15	721454-2-00	1
16	211686-0-00	1
17	211715-0-00	1
18	211692-0-00	1
19	741967-2-00	2
20	211682-0-00	1
21	211539-0-00	1
22	211582-0-00	1
23	202398-0-10	1
24	207856-0-00	1
25	200356-0-10	2
26	209720-0-00	2
27	722441-2-00	2
28	209706-0-00	1
29	211651-0-00	1
30	209683-0-00	1
31	733806-2-00	1
32	722143-2-00	1
33	211583-0-01	1
34	700207-0-00	1

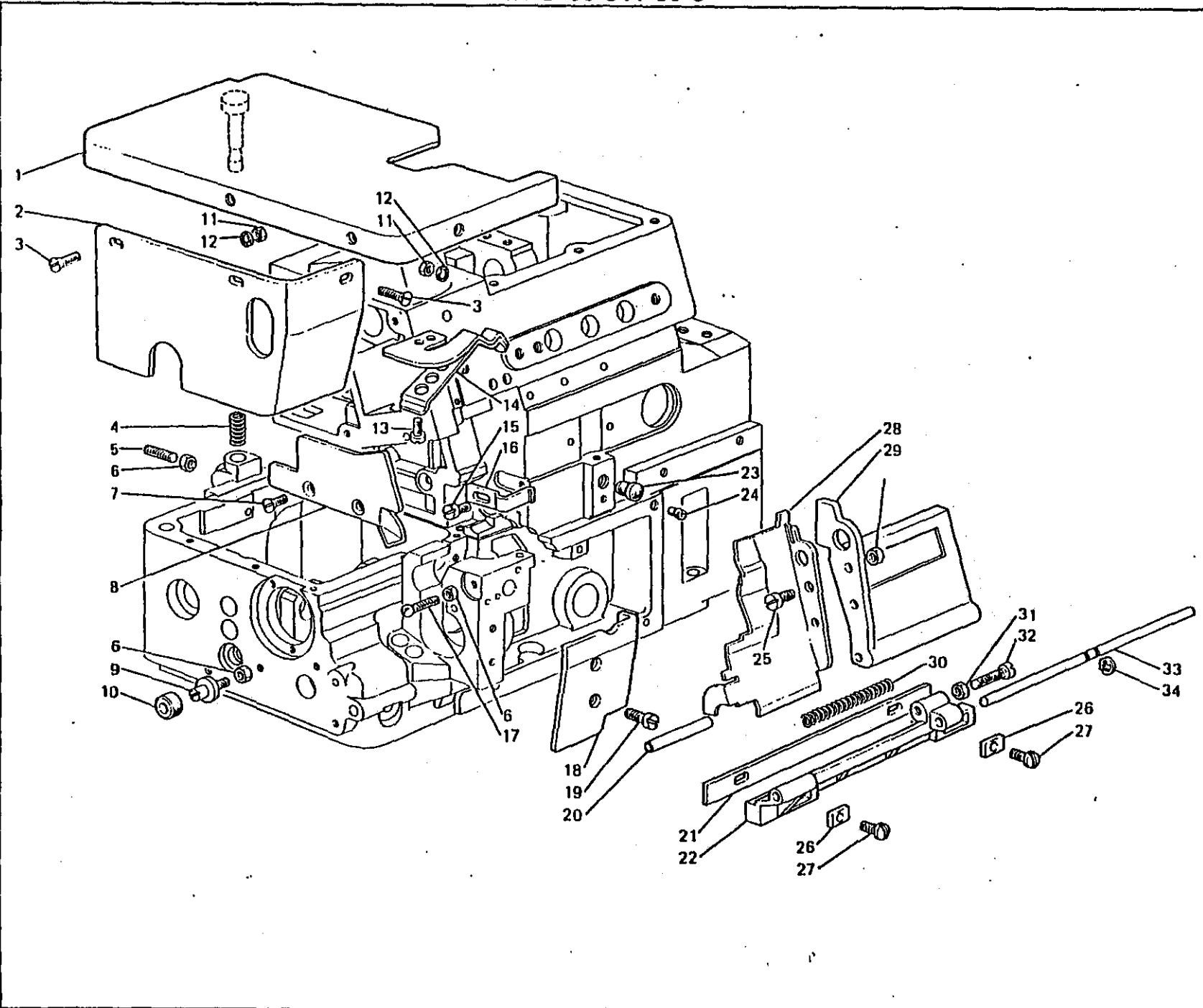

Fig. N.	Part. N. Piece N.	Qt.
1	211704-2-00	1
2	211693-0-00	1
3	744651-0-00	3
4	211410-0-00	1
5	211409-0-00	1
6	746007-2-00	5
7	744730-2-00	2
8	211714-0-00	1
9	211694-0-00	1
10	211028-0-00	1
11	746003-0-00	3
12	703203-0-00	3
13	721423-0-00	2
14	211703-2-00	1
15	721454-2-00	1
16	211686-0-00	1
17	211715-0-00	1
18	211692-0-00	1
19	741967-2-00	2
20	211682-0-00	1
21	211539-0-00	1
22	211582-0-00	1
23	202398-0-10	1
24	207856-0-00	1
25	200356-0-10	2
26	209720-0-00	2
27	722441-2-00	2
28	209685-0-00	1
29	211681-0-00	1
30	209683-0-00	1
31	733806-2-00	1
32	722143-2-00	1
33	211583-0-01	1
34	700207-0-00	1

From the library of Drummond Messers Corp

GRUPPI DI COMPOSIZIONE - COMPOSITION KITS - GROUPES DE KIT - KIT GRUPPEN - GRUPOS DE COMPOSICION

KIT DI CAMPIONATURA  
SETTING KIT  
KIT DE ECHANTILLONAGE  
KIT PROBEENTNAHME  
KIT DE MUESTRARIO

WFS-69

From the library of: D. J. P. M. V. S. Corp

1

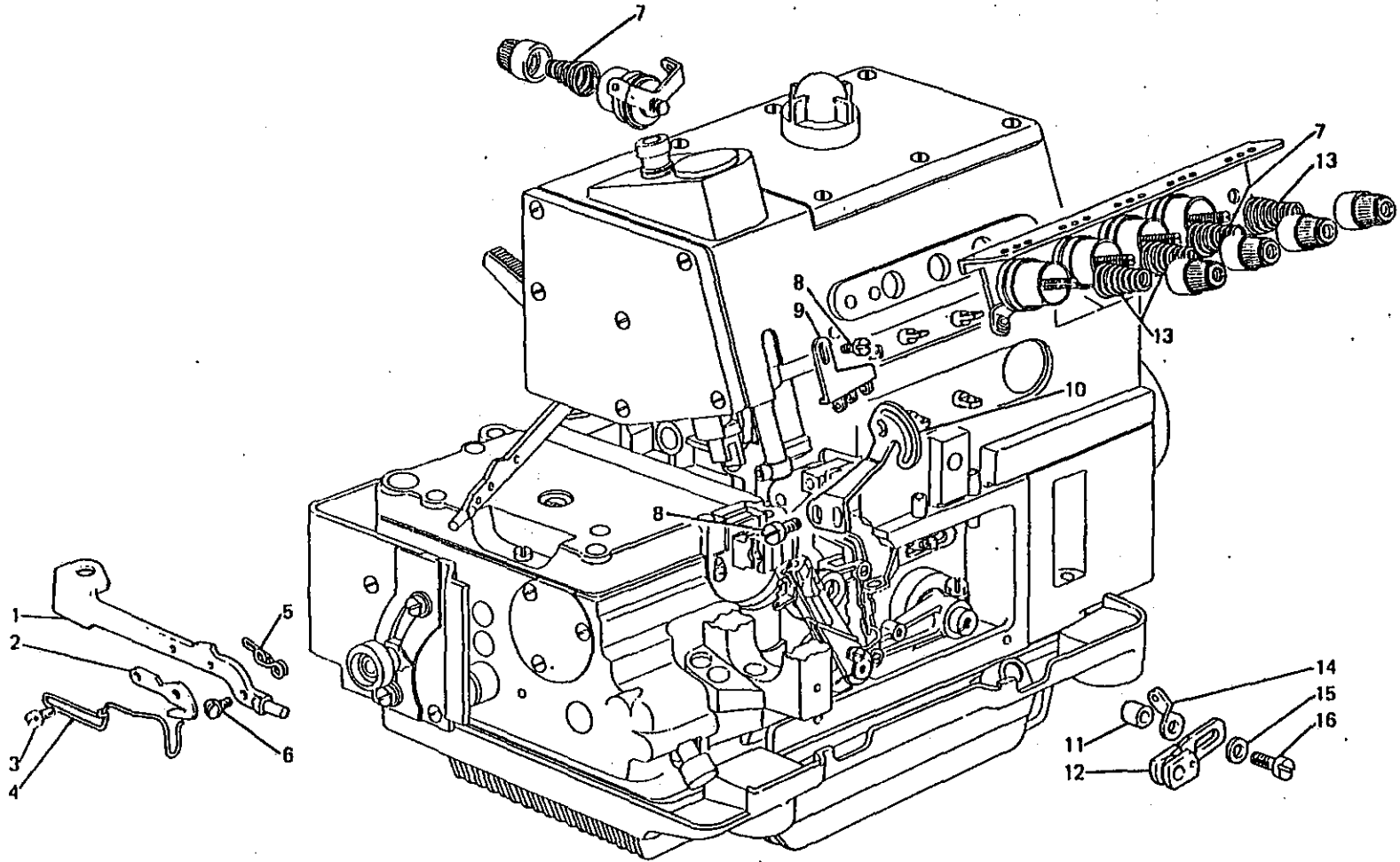
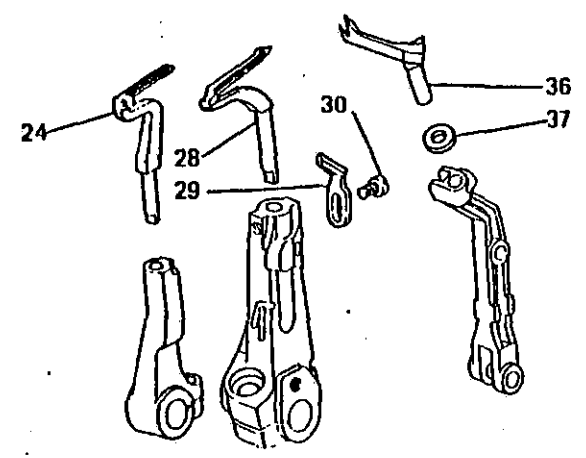
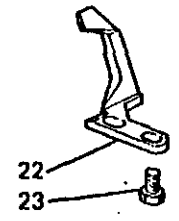
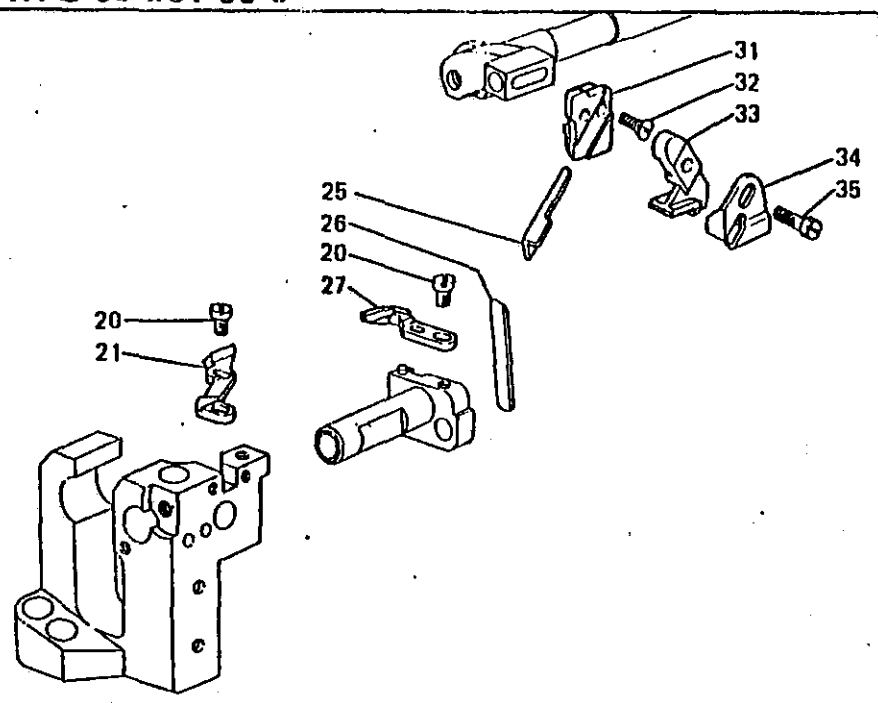
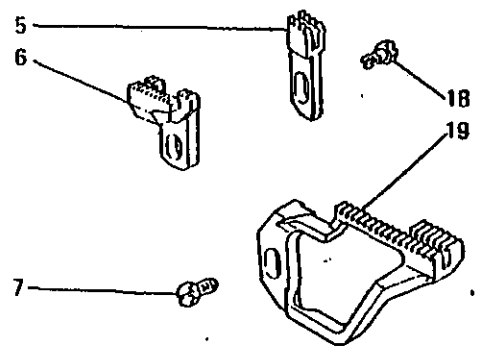
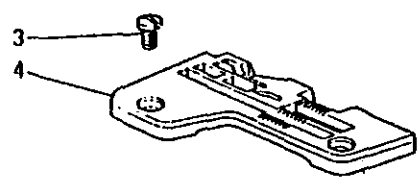
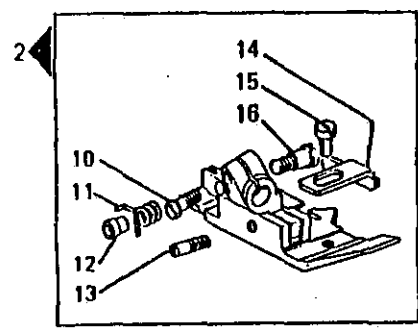
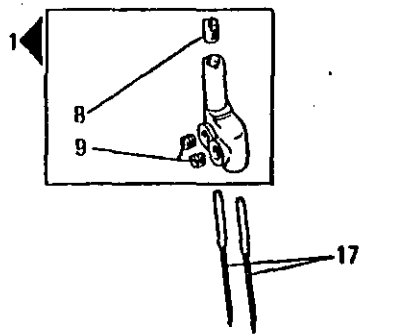

Fig. N.	Part. N. Place N.	Qt.
1	209511-0-00	1
2	202194-0-11	1
3	741433-2-00	2
4	991612-0-00	1
5	204891-0-20	1
6	203187-0-10	1
7	202681-0-10	2
8	741558-0-00	3
9	211143-0-00	1
10	211146-0-00	1
11	211742-0-00	1
12	211743-0-00	1
13	202227-0-10	3
14	211748-0-00	1
15	704104-2-00	1
16	722440-2-00	1

From the library of: Diamond Needle Corp

SEGUE  
FOLLOWS



Fornice Intercontinental Messico Corp.

Fig. N.	Part. N. / Tracca N.	Qt.
1	207524-2-00	1
2	204950-3-12	1
3	744742-2-00	2
4	211638-0-00	1
5	202609-0-10	1
6	211638-0-00	1
7	202489-0-10	1
8	727021-0-00	1
9	745810-2-00	2
10	204947-0-10	1
11	204894-0-11	1
12	204895-0-11	1
13	204869-0-11	1
14	204878-0-11	1
15	741413-2-00	1
16	204889-0-10	1
17	765510-1-80	7
18	202488-0-10	1
19	204666-0-13	1
20	741531-2-00	2
21	209192-0-00	1
22	209279-0-00	1
23	740230-2-00	2
24	211310-0-00	1
25	209356-0-00	2
26	204693-0-11	2
27	209195-0-00	1
28	209264-0-10	1
29	209261-0-00	1
30	741538-2-00	1
31	207650-0-01	1
32	744573-0-00	1
33	207653-0-01	1
34	211137-0-00	1
35	207417-0-01	1
36	211247-0-00	1
37	211301-0-00	1

SEGUE  
FOLLOWS



**CARATTERISTICHE E FUNZIONI DEI PARTICOLARI A RICHIESTA**  
**CHARACTERISTICS AND FUNCTIONS OF REQUESTED SPARE PARTS**  
**CARACTERISTIQUES ET FONCTIONS DES REFERENCES SUR DEMANDE**  
**KENNZEICHEN UND FUNKTIONEN DER TEILE AUF ANFRAGE**  
**CHARACTERISTICAS Y FUNCIONES DE LOS REPUESTOS POR SOLICITUD**

001/3

Fig. N.	X	Y	DESCRIZIONE	DESCRIPTION	DESCRIPTION	BENENNUNG	DESCRIPCION
1	5,5						
2	4,2						
3*		G					
4●		1,5	Per tessuti rigidi.	For rigid fabrics.	Pour tissus rigides.	Für feste Stoffe.	Para tejidos rígidos.
5▲		1,5	Con cromatura antiusura.	With anti-wear plating.	Avec chromage anti-usure.	Mit Chromierung gegen Verschleiss.	Con cromado anti desgaste.
6*		G					
7●		1,5	Per tessuti rigidi.	For rigid fabrics.	Pour tissus rigides.	Für feste Stoffe.	Para tejidos rígidos.
8▲		1,5	Con cromatura antiusura.	With anti-wear plating.	Avec chromage anti-usure.	Mit Chromierung gegen Verschleiss.	Con cromado anti desgaste.
9		W					
10		W	Crochet loro ø 0,7 mm.	Looper hole ø 0,7 mm.	Crochet trou ø 0,7 mm.	Greifer Bohrung ø 0,7 mm.	Garfio orificio ø 0,7 mm.
11		W					
12		WD					
13		AD					
14			Crochet loro ø 0,7 mm.	Looper hole ø 0,7 mm.	Crochet trou ø 0,7 mm.	Greifer Bohrung ø 0,7 mm.	Garfio orificio ø 0,7 mm.

From the library of: Diamond Needle Corp

X	=	LARGHEZZA COSTA	WIDTH OF BIGHT	LARGEUR DE SURJET	UEBERWENDLICHBREITE	ANCHO COSTURA
Y	=	PASSO/FINITURA	DISTANCE/FINISHING	PAS/FINITION	TEILUNG/BEHANDLUNG	PASO/ACABADO
A	=	ACCIAIO	STEEL	ACIER	STAHL	ACERO
D	=	DENTATO	TOOTHED	DENTE	GEZAEHNT	DENTADO
G	=	GOMMATA	RUBBERED	CAOUTCHOUTEE	GUMMIBELEGTEN	ENGOMADO
W	=	WIDIA	WIDIA	WIDIA	WIDIA	WIDIA
* ▲ ●	=	ABBINAMENTI OBBLIGATORI	FIXED COUPLINGS	JUMELAGES OBLIGES	PFLICHT KOPPELUNGEN	COMBINACIONES OBLIGATORIAS

A RICHIESTA PER - ON REQUEST FOR - SUR DEMANDE POUR - AUF ANFRAGE FUER - CON SOLICITUD PARA WFS-69-001-00:0

3

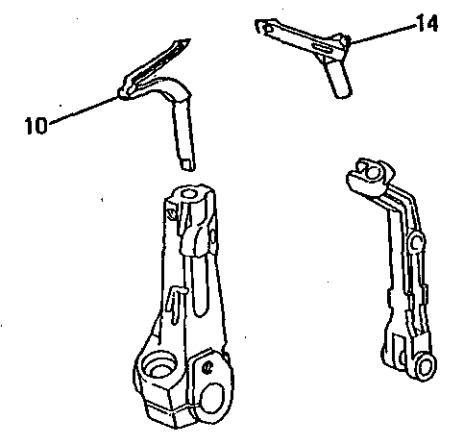
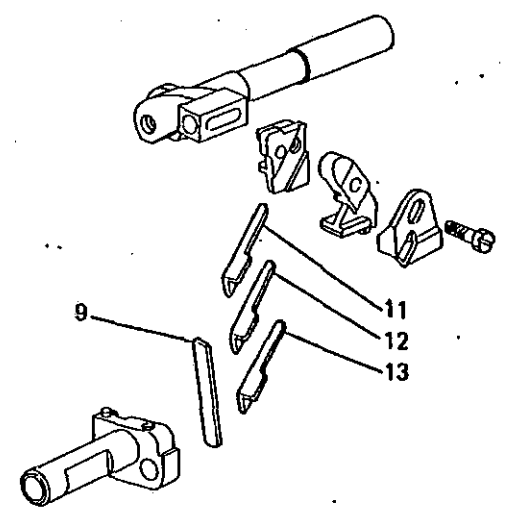
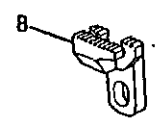
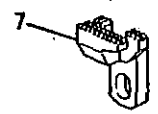
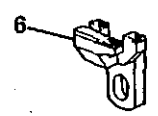
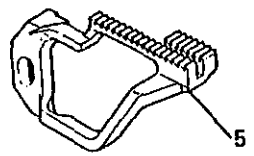
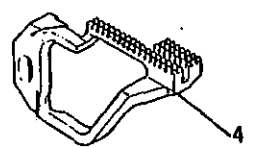
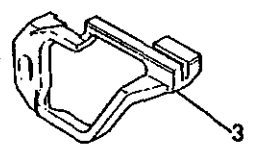
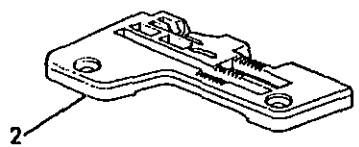
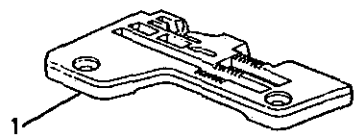

From the library of Diamond Needle Corp

Fig. N.	Part. N. Piece N.	Qt.
1	211636-0-00	1
2	211637-0-00	1
3	204806-2-12	1
4	204998-0-01	1
5	205537-0-01	1
6	211641-2-00	1
7	211642-0-00	1
8	211640-0-00	1
9	207020-2-01	1
10	209268-0-00	1
11	209355-0-00	1
12	209357-0-00	1
13	209358-0-00	2
14	211248-0-00	1

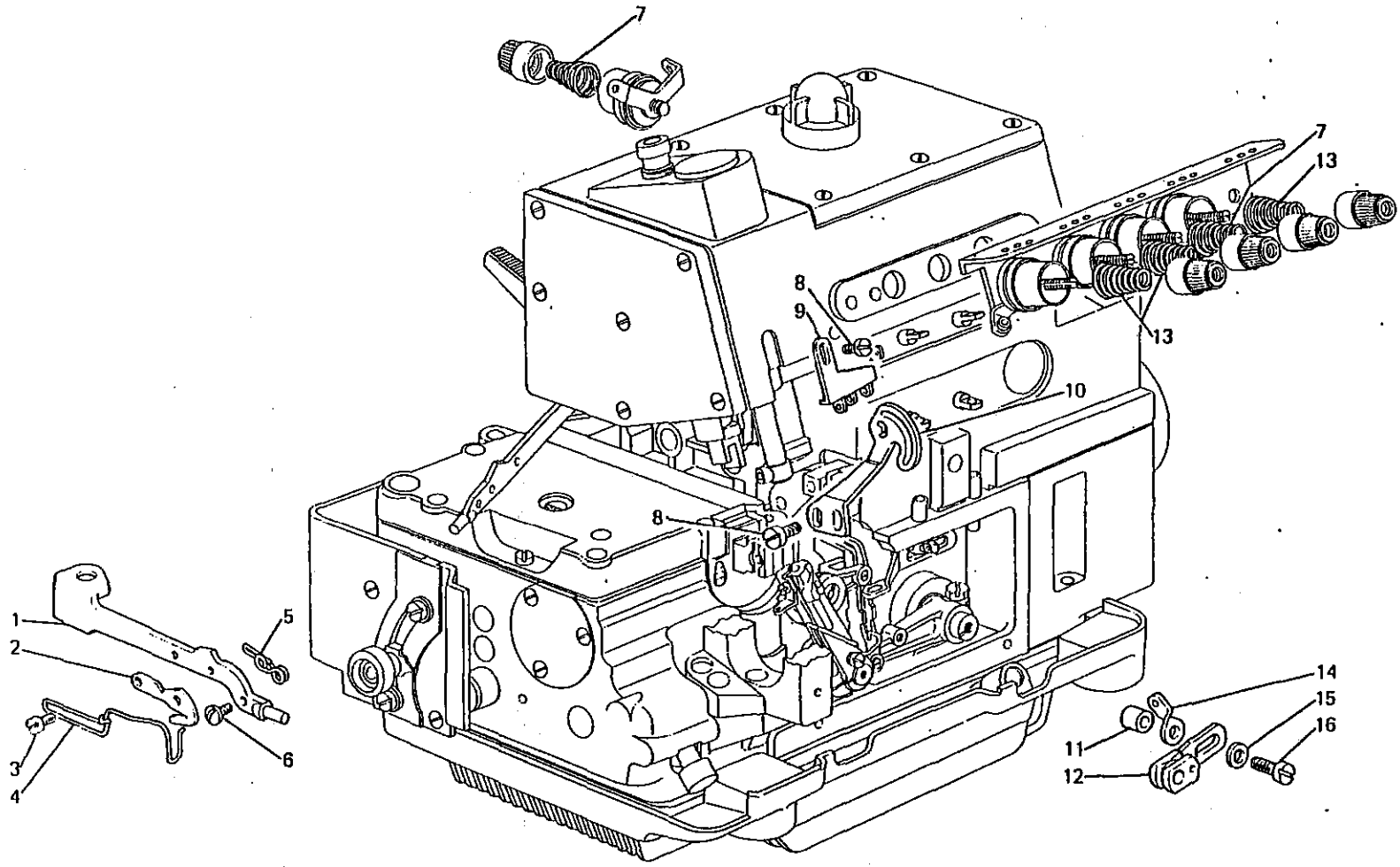

From the library of: Diamond Needle Corp

Fig. N.	Part. N. Piece N.	Qt.
1	209511-0-00	1
2	202194-0-11	1
3	741433-2-00	2
4	991612-0-00	1
5	204891-0-20	1
6	203187-0-10	1
7	202681-0-10	2
8	741558-0-00	3
9	211143-0-00	1
10	211146-0-00	1
11	211742-0-00	1
12	211743-0-00	1
13	202227-0-10	3
14	211748-0-00	1
15	704104-2-00	1
16	722440-2-00	1

SEGUE  
FOLLOWS

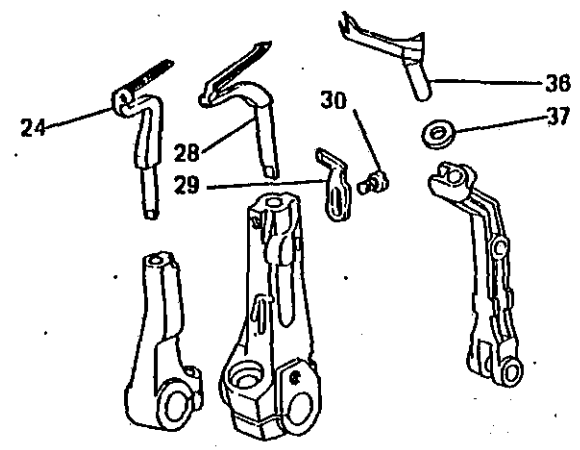
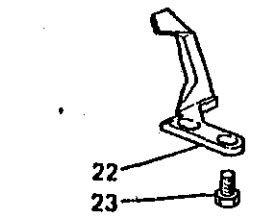
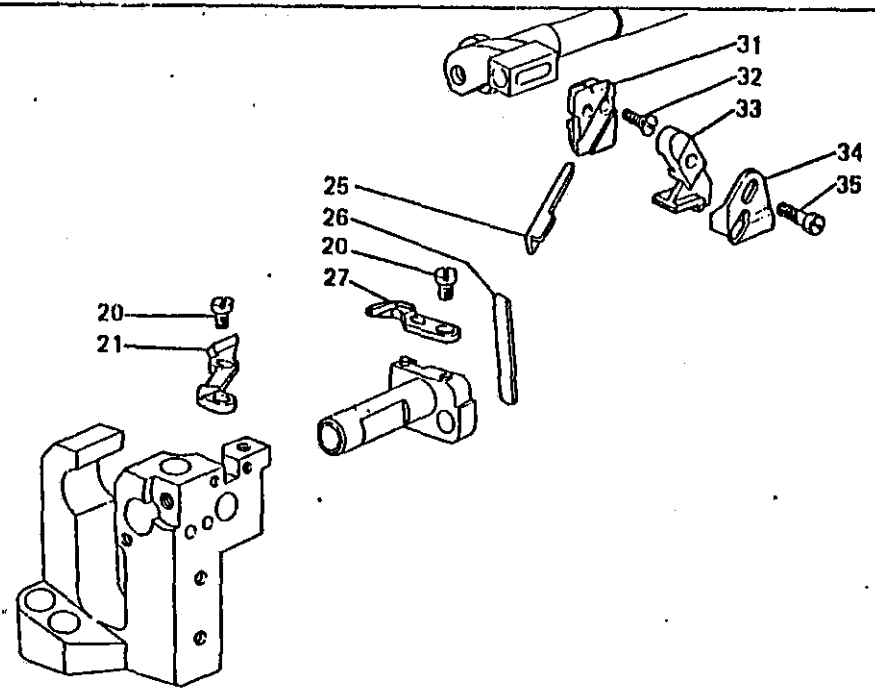
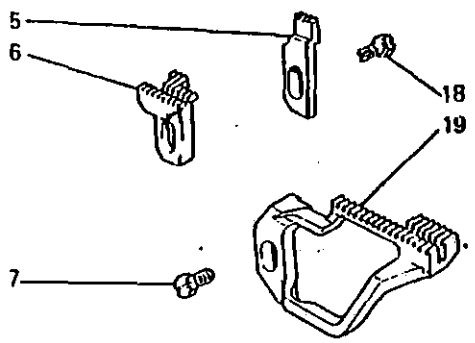
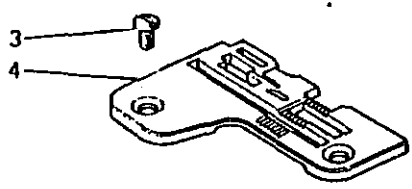
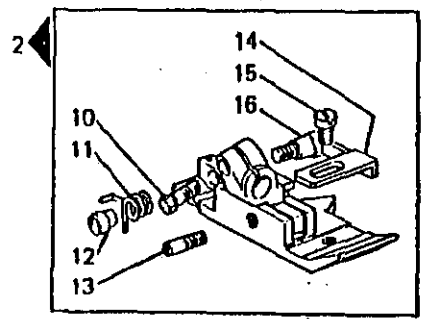
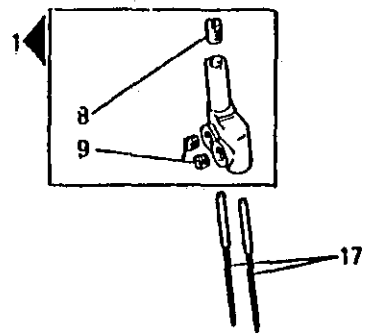

From the library of Diamond Needs Corp

Fig. N.	Part. N. Piece N.	Qt.
1	207525-2-00	1
2	204826-3-11	1
3	744742-2-00	2
4	204821-0-12	1
5	204819-0-10	1
6	204816-0-10	1
7	202489-0-10	1
8	727021-0-00	1
9	745810-2-00	2
10	204947-0-10	1
11	204894-0-11	1
12	204895-0-11	1
13	204869-0-11	1
14	204878-0-11	1
15	741413-2-00	1
16	204889-0-10	1
17	765510-1-80	7
18	202488-0-10	1
19	204813-0-13	1
20	741531-2-00	2
21	209192-0-00	1
22	209279-0-00	1
23	740230-2-00	2
24	211310-0-00	1
25	209356-0-00	2
26	204693-0-11	2
27	209188-0-00	1
28	209264-0-10	1
29	209261-0-00	1
30	741538-2-00	1
31	207650-0-01	1
32	744573-0-00	1
33	207653-0-01	1
34	211137-0-00	1
35	207417-0-01	1
36	211247-0-00	1
37	211301-0-00	1

SEQUE  
FOLLOWS

**CARATTERISTICHE E FUNZIONI DEI PARTICOLARI A RICHIESTA**  
**CHARACTERISTICS AND FUNCTIONS OF REQUESTED SPARE PARTS**  
**CARACTERISTIQUES ET FONCTIONS DES REFERENCES SUR DEMANDE**  
**KENNZEICHEN UND FUNKTIONEN DER TEILE AUF ANFRAGE**  
**CARACTERISTICAS Y FUNCIONES DE LOS REPUESTOS POR SOLICITUD**

002/3

Fig. N.	X	Y	DESCRIZIONE	DESCRIPTION	DESCRIPTION	BENENNUNG	DESCRIPCION
1●			Per evitare lo sfilacciamento con tessuti leggeri.	For preventing fraying with light fabrics.	Pour éviter l'effilochables avec tissus légers.	Um die Auffaserung mit leichten Stoffen zu vermeiden.	Para evitar el deshilachado con tejidos ligeros.
9	3,2						
10	5						
11●	2,5						
12▲		1,5					
13▲		1,5					
14		W					
15			Crochet loro ø 0,7.	Looper hole ø 0,7.	Crochet trou ø 0,7.	Greifer Bohrung ø 0,7.	Garfo orificio ø 0,7.
16		W					
17		WD					
18		AD					
19			Crochet loro ø 0,7.	Looper hole ø 0,7.	Crochet trou ø 0,7.	Greifer Bohrung ø 0,7.	Garfo orificio ø 0,7.

From the library of: Diamond Needle Corp

X	-	LARGHEZZA COSTA	WIDTH OF BIGHT	LARGEUR DE SURJET	UEBERWENDLICHBREITE	ANCHO COSTURA
Y	-	PASSO/FINITURA	DISTANCE/FINISHING	PAS/FINITION	TEILUNG/BEHANDLUNG	PASO/ACABADO
A	-	ACCIAIO	STEEL	ACIER	STAHL	ACERO
D	-	DENTATO	TOOTHED	DENTE	GEZAEHNT	DENTADO
G	-	GOMMATA	RUBBERED	CAOUTCHOUTEE	GUMMIBELEGTEN	ENGOMADO
W	-	WIDIA	WIDIA	WIDIA	WIDIA	WIDIA
* ▲ ■ ●	-	ABBINAMENTI OBBLIGATORI	FIXED COUPLINGS	JUMELAGES OBLIGES	PFLICHT KOPPELUNGEN	COMBINACIONES OBLIGATORIAS

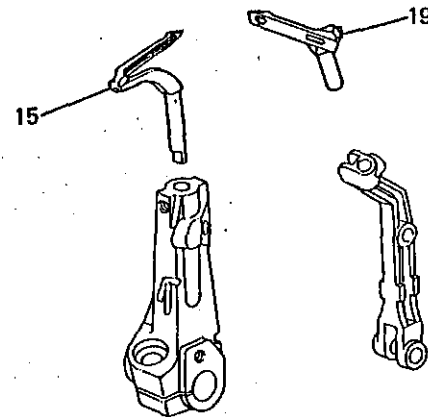
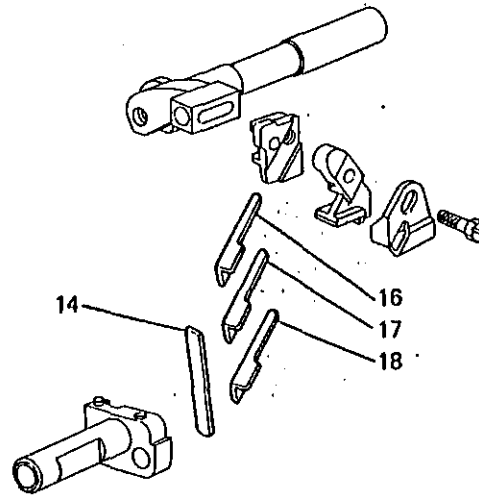
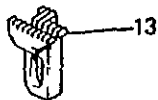
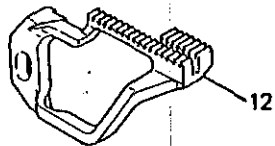
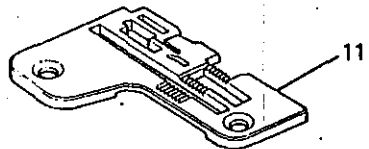
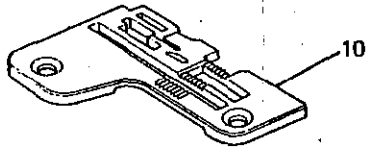
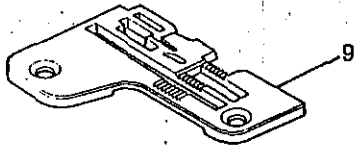
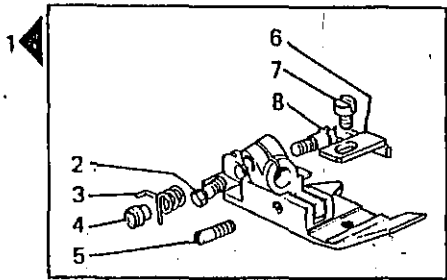

From the library of: Diamond Needle Corp

Fig. N.	Part. N. Piece N.	Qt.
1	205084-3-11	1
2	204947-0-10	1
3	204894-0-11	1
4	204895-0-11	1
5	204869-0-11	1
6	205088-0-11	1
7	741433-2-00	1
8	204889-0-10	1
9	204837-0-01	1
10	204838-0-01	1
11	205082-0-11	1
12	205539-0-01	1
13	205538-0-00	1
14	207020-2-01	1
15	209268-0-00	1
16	209355-0-00	1
17	209357-0-00	1
18	209358-0-00	2
19	211248-0-00	1

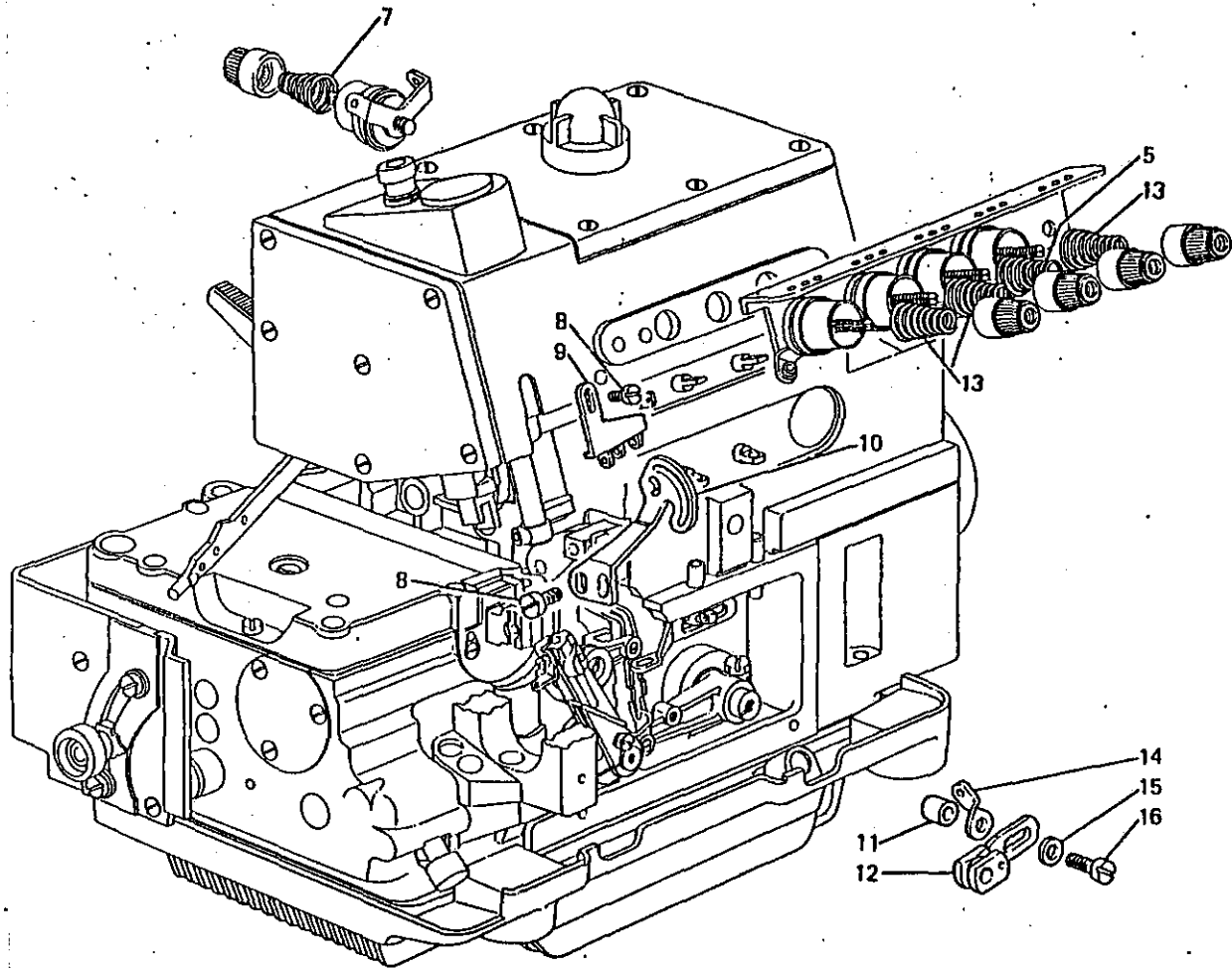
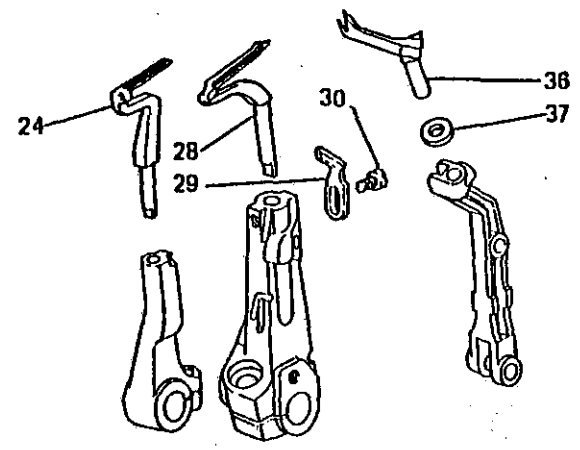
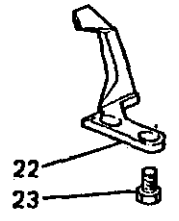
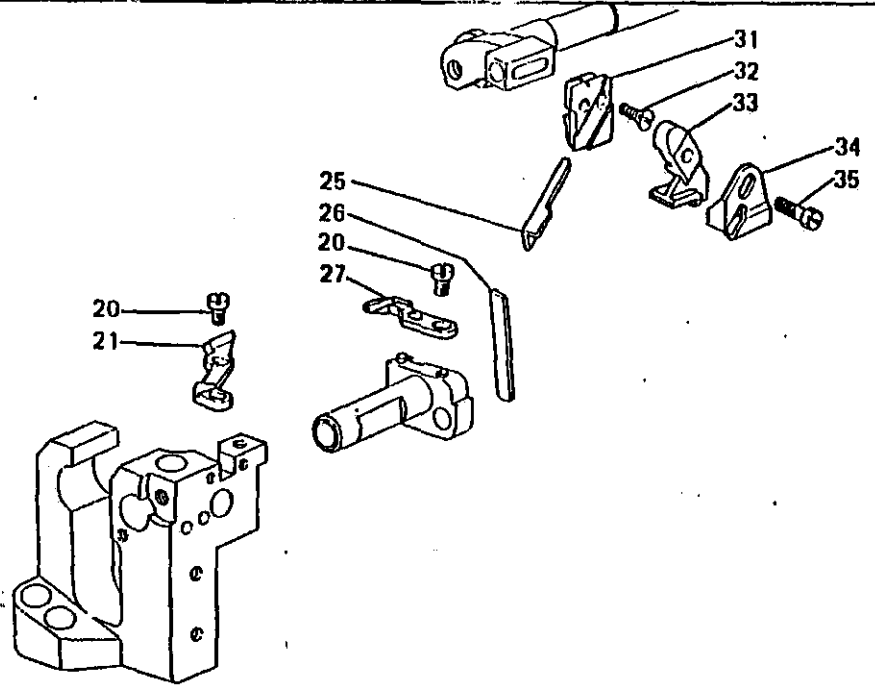
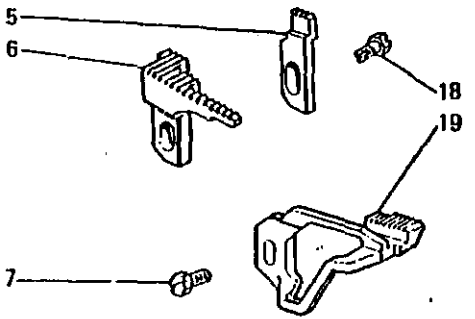
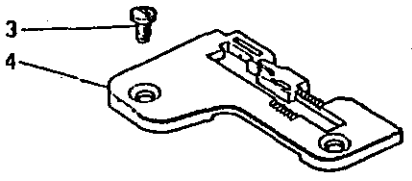
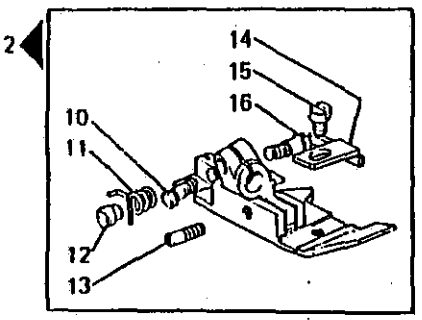
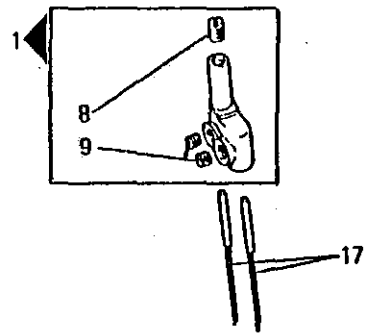

Fig. N.	Part. N. Piece N.	Qt.
1	209511-0-00	1
2	202194-0-11	1
3	741433-2-00	2
4	991612-0-00	1
5	204836-0-10	1
6	203187-0-10	1
7	202681-0-10	2
8	741558-0-00	3
9	211143-0-00	1
10	211146-0-00	1
11	211742-0-00	1
12	211743-0-00	1
13	202227-0-10	3
14	211748-0-00	1
15	704104-2-00	1
16	722440-2-00	1

From the library of: Diamond Needle Corp

SEGUE  
FOLLOWS



From the library of Diamond Needle Corp

Fig. N.	Part N. Piece It.	Qt.
1	207525-2-00	1
2	204827-3-11	1
3	744742-2-00	2
4	208075-0-00	1
5	204819-0-10	1
6	204817-0-10	1
7	202489-0-10	1
8	727021-0-00	1
9	745810-2-00	2
10	204947-0-10	1
11	204894-0-11	1
12	204895-0-11	1
13	204869-0-11	1
14	204878-0-11	1
15	741413-2-00	1
16	204889-0-10	1
17	765510-1-80	7
18	202488-0-10	1
19	208076-0-00	1
20	741531-2-00	2
21	209192-0-00	1
22	209279-0-00	1
23	740230-2-00	2
24	211310-0-00	1
25	209356-0-00	2
26	204693-0-11	2
27	209188-0-00	1
28	209264-0-10	1
29	209261-0-00	1
30	741538-2-00	1
31	207650-0-01	1
32	744573-0-00	1
33	207653-0-01	1
34	211137-0-00	1
35	207417-0-01	1
36	211247-0-00	1
37	211301-0-00	1

SEGUE  
FOLLOWS



**CARATTERISTICHE E FUNZIONI DEI PARTICOLARI A RICHIESTA**  
**CHARACTERISTICS AND FUNCTIONS OF REQUESTED SPARE PARTS**  
**CARACTERISTIQUES ET FONCTIONS DES REFERENCES SUR DEMANDE**  
**KENNZEICHEN UND FUNKTIONEN DER TEILE AUF ANFRAGE**  
**CARACTERISTICAS Y FUNCIONES DE LOS REPUESTOS POR SOLICITUD**

003/3

Fig. N.	X	Y	DESCRIZIONE	DESCRIPTION	DESCRIPTION	BENENNUNG	DESCRIPCION
1			Per evitare lo sfilacciamento con tessuti leggeri.	For preventing fraying with light fabrics.	Pour éviter l'effilochables avec tissus légers.	Um die Auffaserung mit leichten Stoffen zu vermeiden.	Para evitar el deshilachado con tejidos ligeros.
9		W					
10			Crochet loro ø 0,7.	Looper hole ø 0,7.	Crochet trou ø 0,7.	Greifer Bohrung ø 0,7.	Garfio orificio ø 0,7.
11		W					
12		WD					
13		AD					
14			Crochet loro ø 0,7.	Looper hole ø 0,7.	Crochet trou ø 0,7.	Greifer Bohrung ø 0,7.	Garfio orificio ø 0,7.

From the library of: Diamond Needle Corp.

- |         |   |                         |                    |                   |                     |                            |
|---------|---|-------------------------|--------------------|-------------------|---------------------|----------------------------|
| X       | - | LARGHEZZA COSTA         | WIDTH OF BIGHT     | LARGEUR DE SURJET | UEBERWENDLICHBREITE | ANCHO COSTURA              |
| Y       | - | PASSO/FINITURA          | DISTANCE/FINISHING | PAS/FINITION      | TEILUNG/BEHANDLUNG  | PASO/ACABADO               |
| A       | - | ACCIAIO                 | STEEL              | ACIER             | STAHL               | ACERO                      |
| D       | - | DENTATO                 | TOOTHED            | DENTE             | GEZAEHNT            | DENTADO                    |
| G       | - | GOMMATA                 | RUBBERED           | CAOUTCHOUTEE      | GUMMIBELEGTEN       | ENGOMADO                   |
| W       | - | WIDIA                   | WIDIA              | WIDIA             | WIDIA               | WIDIA                      |
| * ▲ ■ ● | - | ABBINAMENTI OBBLIGATORI | FIXED COUPLINGS    | JUMELAGES OBLIGES | PFLICHT KOPPELUNGEN | COMBINACIONES OBLIGATORIAS |

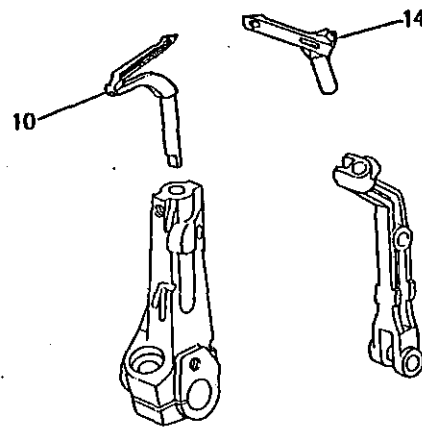
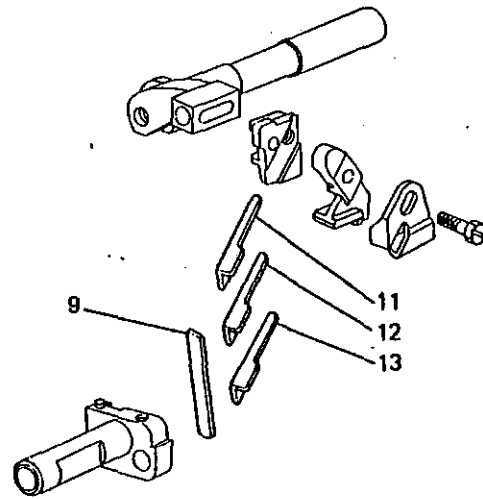
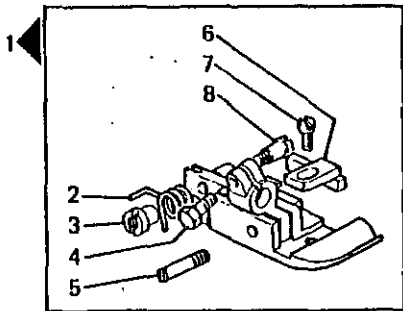

From the library of: Diamond Needle Corp

Fig. N.	Part. N. Piese N.	Qt.
1	205085-3-11	1
2	204894-0-11	1
3	204895-0-11	1
4	204947-0-10	1
5	204869-0-11	1
6	205088-0-11	1
7	741433-2-00	1
8	204889-0-10	1
9	207020-2-01	1
10	209268-0-00	1
11	209355-0-00	1
12	209357-0-00	1
13	209358-0-00	2
14	211248-0-00	1

1

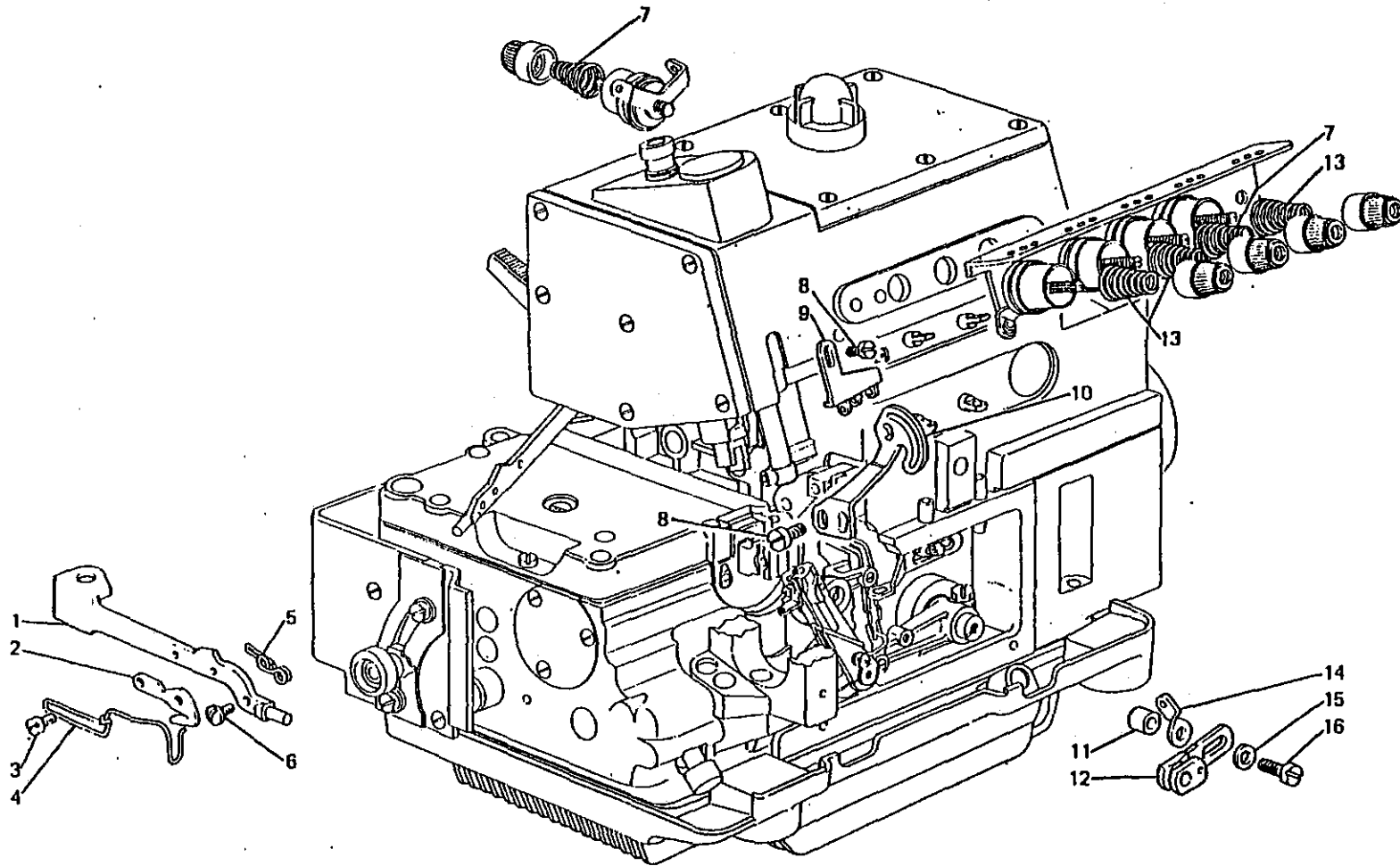
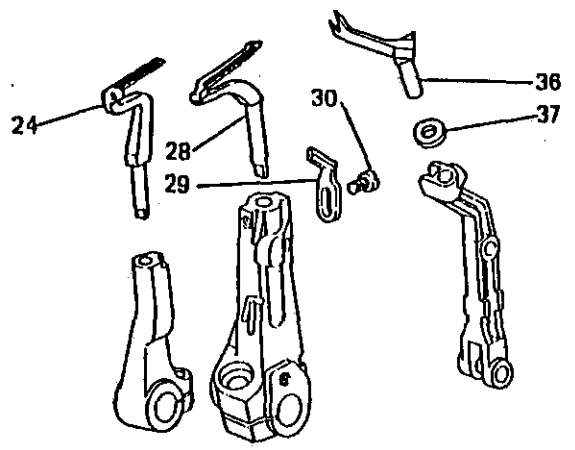
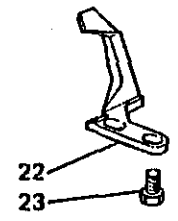
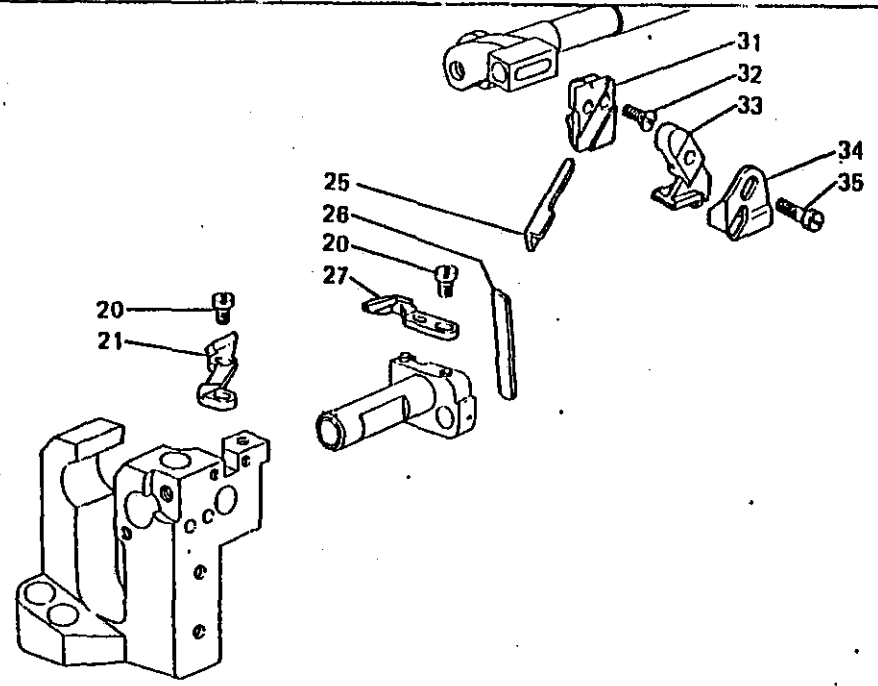
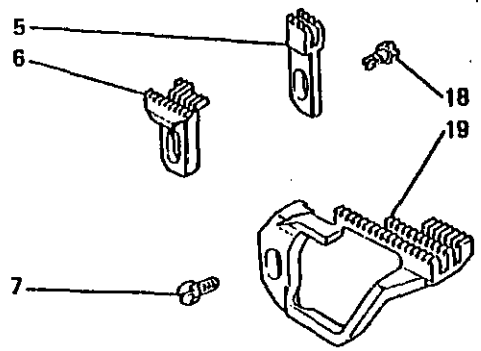
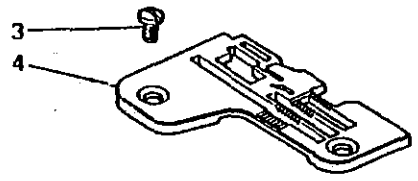
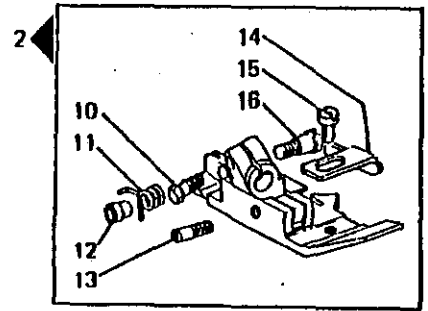
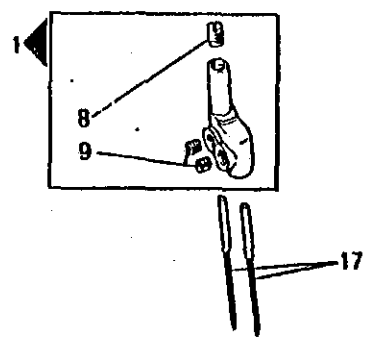

Fig. N.	Part. N. Piece N.	Qt.
1	209511-0-00	1
2	202194-0-11	1
3	741433-2-00	2
4	891612-0-00	1
5	204891-0-20	1
6	203187-0-10	1
7	202681-0-10	2
8	741558-0-00	3
9	211143-0-00	1
10	211146-0-00	1
11	211742-0-00	1
12	211743-0-00	1
13	202227-0-10	3
14	211748-0-00	1
15	704104-2-00	1
16	722440-2-00	1

From the library of: Diamond Needle Corp

SEGUE  
FOLLOWS



From the library of: Diamond Needle Corp

Fig. N.	Part N. Piece N.	Qt.
1	207524-2-00	1
2	204950-3-12	1
3	744742-2-00	2
4	204864-0-13	1
5	202609-0-10	1
6	204850-0-10	1
7	202489-0-10	1
8	727021-0-00	1
9	745810-2-00	2
10	204947-0-10	1
11	204894-0-11	1
12	204895-0-11	1
13	204869-0-11	1
14	204878-0-11	1
15	741413-2-00	1
16	204889-0-10	1
17	765510-1-80	7
18	202488-0-10	1
19	204846-0-13	1
20	741531-2-00	2
21	209192-0-00	1
22	209279-0-00	1
23	740230-2-00	2
24	211310-0-00	1
25	209356-0-00	2
26	204693-0-11	2
27	209195-0-00	1
28	209264-0-10	1
29	209261-0-00	1
30	741538-2-00	1
31	207650-0-01	1
32	744573-0-00	1
33	207653-0-01	1
34	211137-0-00	1
35	207417-0-01	1
36	211247-0-00	1
37	211301-0-00	1

SEGUE  
FOLLOWS

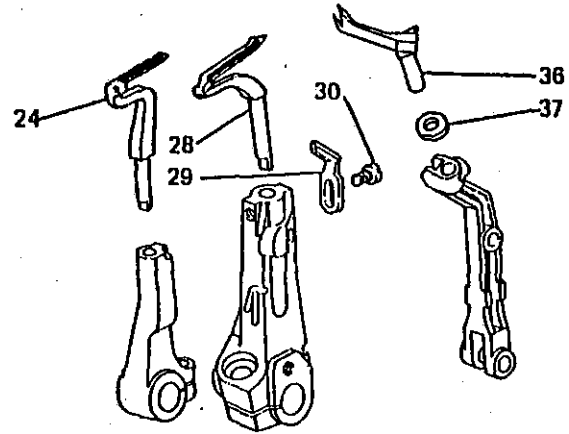
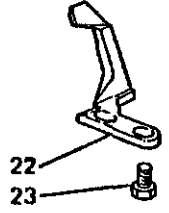
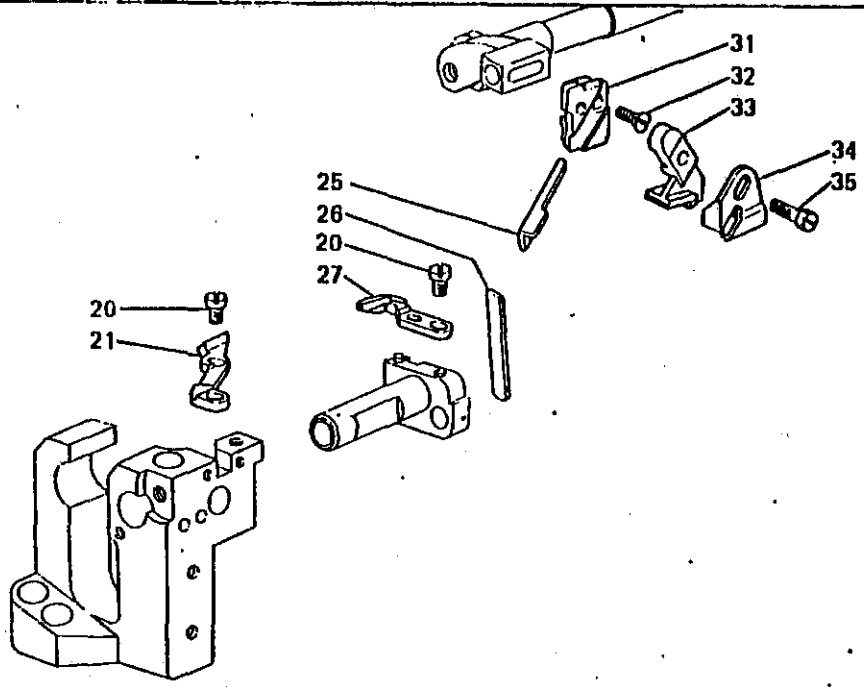
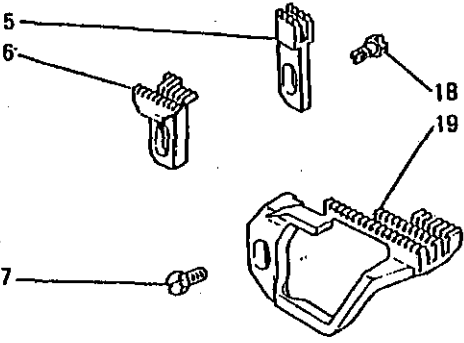
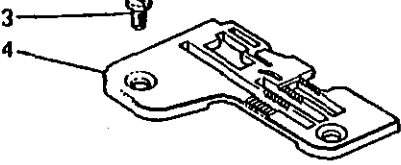
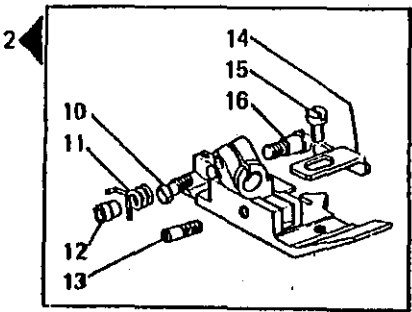
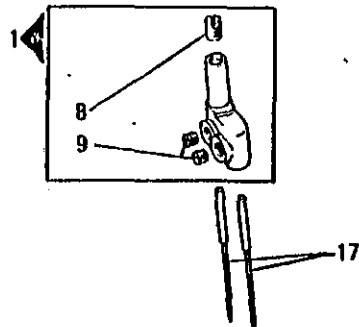
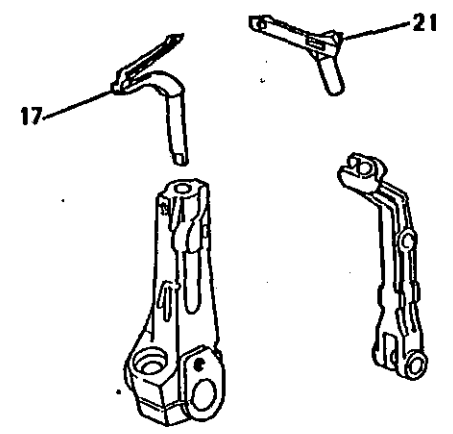
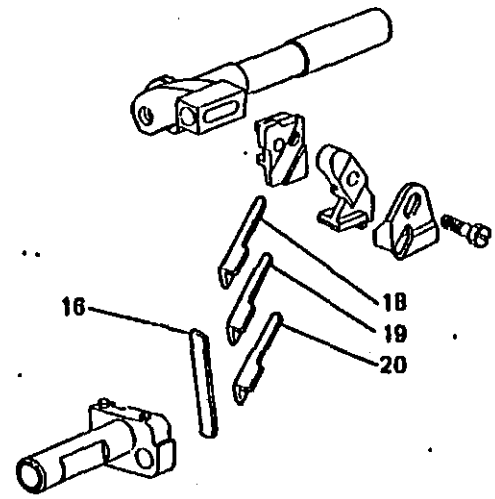
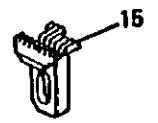
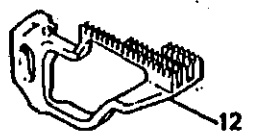
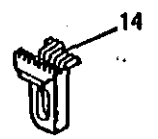
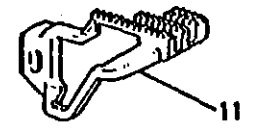
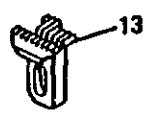
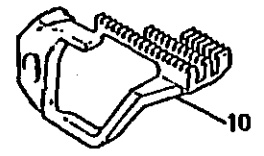
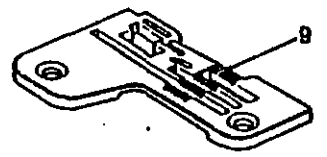
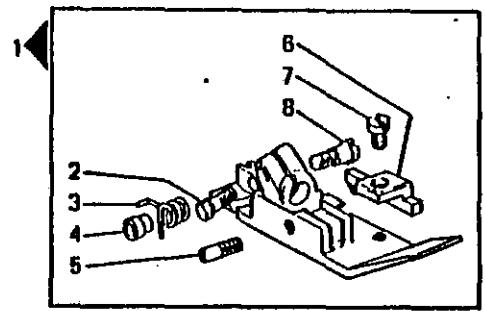

Fig. N.	Part N. Piece N.	Qt.
1	207524-2-00	1
2	204950-3-12	1
3	744742-2-00	2
4	204864-0-13	1
5	202609-0-10	1
6	204850-0-10	1
7	202489-0-10	1
8	727021-0-00	1
9	745810-2-00	2
10	204947-0-10	1
11	204894-0-11	1
12	204895-0-11	1
13	204869-0-11	1
14	204878-0-11	1
15	741413-2-00	1
16	204889-0-10	1
17	765510-1-90	7
18	202488-0-10	1
19	204846-0-13	1
20	741531-2-00	2
21	209192-0-00	1
22	209279-0-00	1
23	740230-2-00	2
24	211310-0-00	1
25	209356-0-00	2
26	204653-0-11	2
27	209195-0-00	1
28	209264-0-10	1
29	209261-0-00	1
30	741538-2-00	1
31	207650-0-01	1
32	744573-0-00	1
33	207653-0-01	1
34	211137-0-00	1
35	207417-0-01	1
36	211247-0-00	1
37	211301-0-00	1

From the library of Diamond Research Corp

SEGUE  
FOLLOWS



From the library of: Diamond Needle Corp

Fig. N.	Part. N. Piece N.	Qt.
1	205103-3-11	1
2	204947-0-10	1
3	204894-0-11	1
4	204895-0-11	1
5	204869-0-11	1
6	205105-0-11	1
7	741445-2-00	1
8	204889-0-10	1
9	205102-0-13	1
10	204940-0-13	1
11	204941-0-13	1
12	204897-0-01	1
13	204942-0-10	1
14	204943-0-11	1
15	204851-0-11	1
16	207020-2-01	1
17	209268-0-00	1
18	209355-0-00	1
19	209357-0-00	1
20	209358-0-00	2
21	211248-0-00	1

SEQUE  
FOLLOWS

**CARATTERISTICHE E FUNZIONI DEI PARTICOLARI A RICHIESTA**  
**CHARACTERISTICS AND FUNCTIONS OF REQUESTED SPARE PARTS**  
**CARACTERISTIQUES ET FONCTIONS DES REFERENCES SUR DEMANDE**  
**KENNZEICHEN UND FUNKTIONEN DER TEILE AUF ANFRAGE**  
**CARACTERISTICAS Y FUNCIONES DE LOS REPUESTOS POR SOLICITUD**

004/3

Fig. N.	X	Y	DESCRIZIONE	DESCRIPTION	DESCRIPTION	BENENNUNG	DESCRIPCION	
1■	3,5		Per risvoltare verso il basso con tessuti sfilacciabili.	For folding downwards fraying fabrics.	Pour replier en bas les tissus effilochables.	Um die Kanten aus Aufaserungstoffen nach unten aufzurollen.	Para doblar hacia abajo con tejidos deshilachables.	
9■								
10●		2						
11▲		2						
12★		1,5						
13●		2						
14▲		2						
15★		1,5						
16		W						
17		W		Crochet foro ø 0,7.	Looper hole ø 0,7.	Crochet trou ø 0,7.	Greifer Bohrung ø 0,7.	Garfio orificio ø 0,7.
18		WD						
19		AD						
20								
21				Crochet foro ø 0,7.	Looper hole ø 0,7.	Crochet trou ø 0,7.	Greifer Bohrung ø 0,7.	Garfio orificio ø 0,7.

From the library of: Diamond Needle Corp

X	=	LARGHEZZA COSTA	WIDTH OF BIGHT	LARGEUR DE SURJET	UEBERWENDLICHBREITE	ANCHO COSTURA
Y	=	PASSO/FINITURA	DISTANCE/FINISHING	PAS/FINITION	TEILUNG/BEHANDLUNG	PASO/ACABADO
A	=	ACCIAIO	STEEL	ACIER	STAHL	ACERO
D	=	DENTATO	TOOTHED	DENTE	GEZAEHNT	DENTADO
G	=	GOMMATA	RUBBERED	CAOUTCHOUTEE	GUMMIBELEGTEN	ENGOMADO
W	=	WIDIA	WIDIA	WIDIA	WIDIA	WIDIA
★ ▲ ■ ●	=	ABBINAMENTI OBBLIGATORI	FIXED COUPLINGS	JUMELAGES OBLIGES	PFLICHT KOPPELUNGEN	COMBINACIONES OBLIGATORIAS

**CARATTERISTICHE E FUNZIONI DEI PARTICOLARI A RICHIESTA**  
**CHARACTERISTICS AND FUNCTIONS OF REQUESTED SPARE PARTS**  
**CARACTERISTIQUES ET FONCTIONS DES REFERENCES SUR DEMANDE**  
**KENNZEICHEN UND FUNKTIONEN DER TEILE AUF ANFRAGE**  
**CARACTERISTICAS Y FUNCIONES DE LOS REPUESTOS POR SOLICITUD**

004/3

Fig. N.	X	Y	DESCRIZIONE	DESCRIPTION	DESCRIPTION	BENENNUNG	DESCRIPCION
1			Per risvoltare verso il basso con tessuti stilacciabili.	For folding downwards traying fabrics.	Pour replier en bas les tissus effilochables.	Um die Kanten aus Aufzaserungstoffen nach unten aufzurollen.	Para doblar hacia abajo con tejidos deshilachables.
9	3,5						
10		2					
11A		2					
12*		1,5					
13		2					
14A		2					
15*		1,5					
16		W					
17		W	Crochet foro ø 0,7.	Looper hole ø 0,7.	Crochet trou ø 0,7.	Greifer Bohrung ø 0,7.	Garfo orificio ø 0,7.
18		W					
19		WD					
20		AD					
21			Crochet foro ø 0,7.	Looper hole ø 0,7.	Crochet trou ø 0,7.	Greifer Bohrung ø 0,7.	Garfo orificio ø 0,7.

From the library of: Diamond Needle Corp

X	-	LARGHEZZA COSTA	WIDTH OF BIGHT	LARGEUR DE SURJET	UEBERWENDLICHBREITE	ANCHO COSTURA
Y	-	PASSO/FINITURA	DISTANCE/FINISHING	PAS/FINITION	TEILUNG/BEHANDLUNG	PASO/ACABADO
A	-	ACCIAIO	STEEL	ACIER	STAHL	ACERO
D	-	DENTATO	TOOTHED	DENTE	GEZAEHNT	DENTADO
G	-	GOMMATA	RUBBERED	CAOUTCHOUTEE	GUMMIBELGTE	ENGOMADO
W	-	WIDIA	WIDIA	WIDIA	WIDIA	WIDIA
* ▲ ■ ●	-	ABBINAMENTI OBBLIGATORI	FIXED COUPLINGS	JUMELAGES OBLIGES	PFLICHT KOPPELUNGEN	COMBINACIONES OBLIGATORIAS



A RICHIESTA PER · ON REQUEST FOR · SUR DEMANDE POUR · AUF ANFRAGE FUER · CON SOLICITUD PARA WFS-69-004-D0-D

4

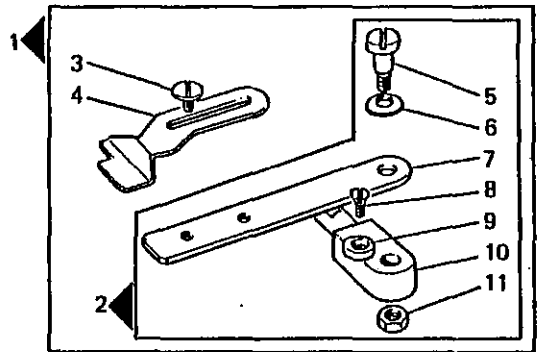
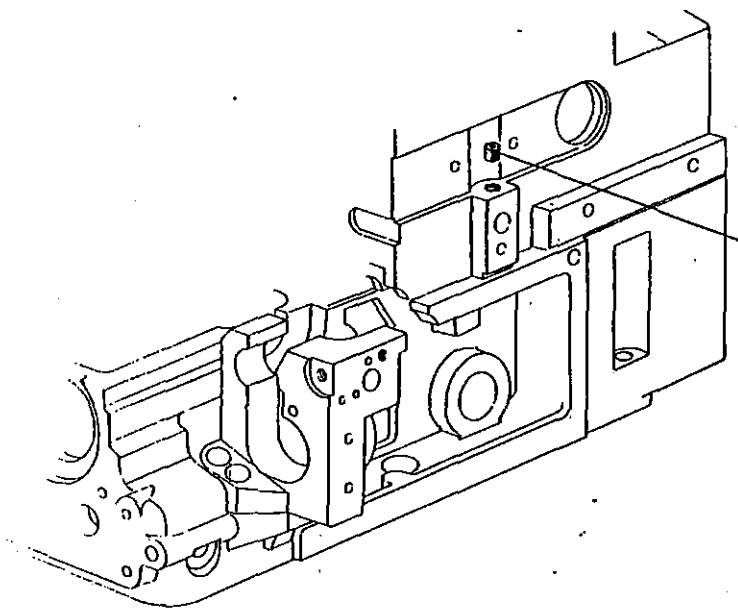

Fig. N.	Part. N. Piece N.	Qt.
1	204919-4-11	1
2	204960-4-00	1
3	201236-0-10	2
4	204920-0-20	1
5	743464-2-00	1
6	702406-0-00	1
7	204647-0-00	1
8	744730-2-00	1
9	300710-0-10	1
10	202970-0-20	1
11	746007-2-00	1
12	729013-2-00	1

From the library of: Diamond Needle Corp

**CARATTERISTICHE E FUNZIONI DEI PARTICOLARI A RICHIESTA**  
**CHARACTERISTICS AND FUNCTIONS OF REQUESTED SPARE PARTS**  
**CARACTERISTIQUES ET FONCTIONS DES REFERENCES SUR DEMANDE**  
**KENNZEICHEN UND FUNKTIONEN DER TEILE AUF ANFRAGE**  
**CARACTERISTICAS Y FUNCIONES DE LOS REPUESTOS POR SOLICITUD**

004/4

Fig. N.	X	Y	DESCRIZIONE	DESCRIPTION	DESCRIPTION	BENENNUNG	DESCRIPCION
1			Guida ribaltabile per limitare l'altezza del taglio	Folder for limiting cutting thickness.	Guide escamotable pour limiter la hauteur de coupe.	Klappführung um die Schneidhöhe zu begrenzen.	Guía volcable para limitar la altura del corte.

From the library of: Diamond Needle Corp

X	-	LARGHEZZA COSTA	WIDTH OF BIGHT	LARGEUR DE SURJET	UEBERWENDLICHBREITE	ANCHO COSTURA
Y	-	PASSO/FINITURA	DISTANCE/FINISHING	PAS/FINITION	TEILUNG/BEHANDLUNG	PASO/ACABADO
A	-	ACCIAIO	STEEL	ACIER	STAHL	ACERO
D	-	DENTATO	TOOTHED	DENTE	GEZAEHNT	DENTADO
G	-	GOMMATA	RUBBERED	CAOUTCHOUTEE	GUMMIBELEGTEN	ENGOMADO
W	-	WIDIA	WIDIA	WIDIA	WIDIA	WIDIA
* ▲ ■ ●	-	ABBINAMENTI OBBLIGATORI	FIXED COUPLINGS	JUMELAGES OBLIGES	PFLICHT KOPPELUNGEN	COMBINACIONES OBLIGATORIAS

1

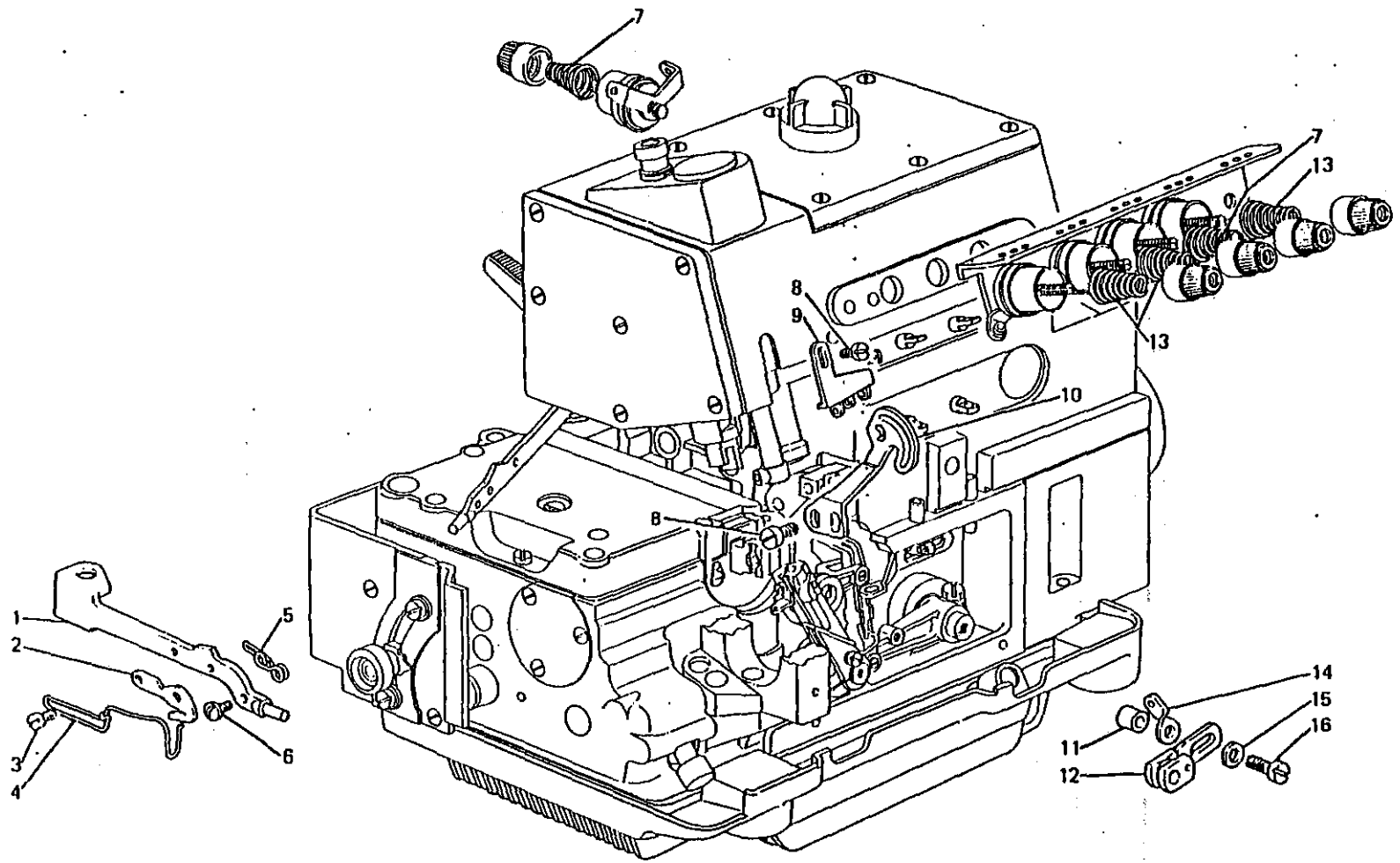
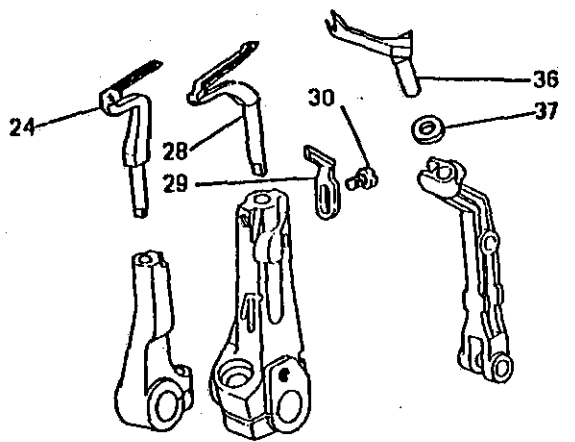
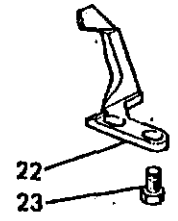
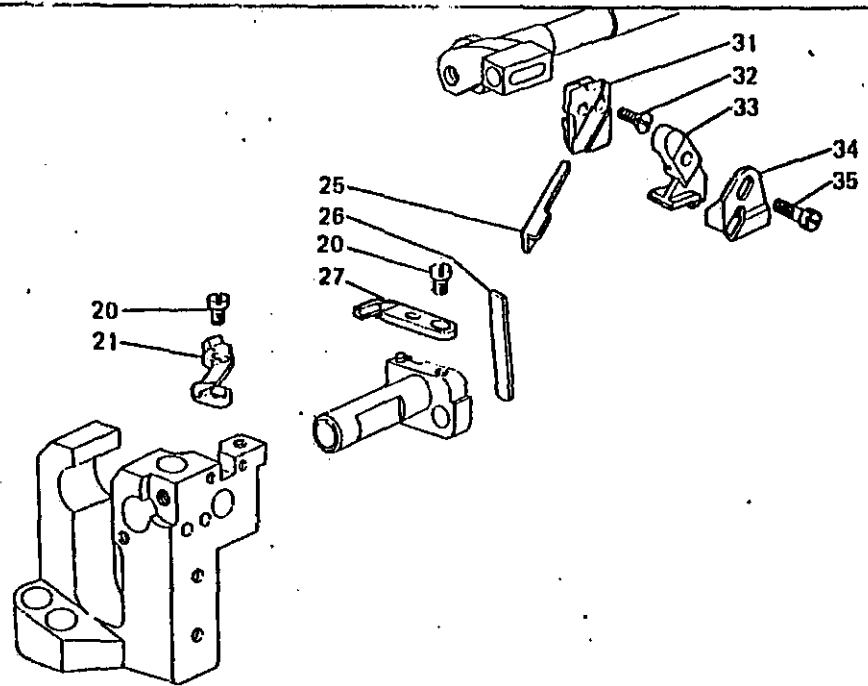
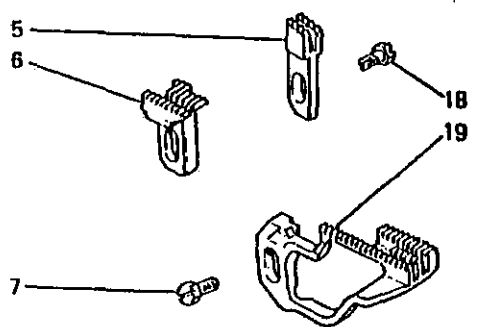
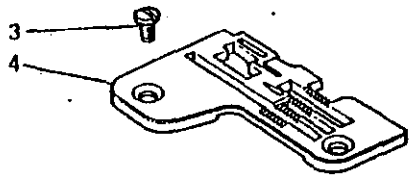
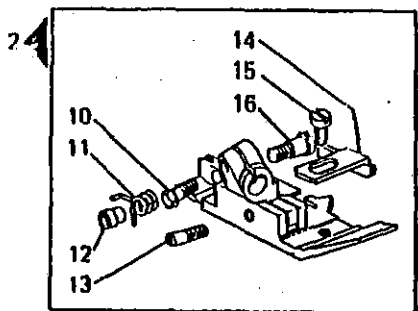
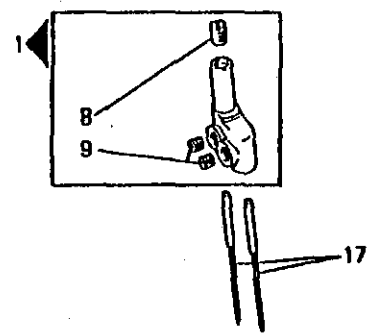

Fig. N.	Part. N. Piece N.	Qt.
1	209511-0-00	1
2	202194-0-11	1
3	741433-2-00	2
4	991612-0-00	1
5	205042-0-20	1
6	203187-0-10	1
7	202681-0-10	2
8	741558-0-00	3
9	211144-0-00	1
10	211146-0-00	1
11	211742-0-00	1
12	211743-0-00	1
13	202227-0-10	3
14	211748-0-00	1
15	704104-2-00	1
16	722440-2-00	1

From the library of: Diamond Needle Corp

SEGUE  
FOLLOWS



From the library of: Diamond Needle Corp

Fig. N.	Part N. Piece N.	Qt.
1	207526-2-00	1
2	205070-3-12	1
3	744742-2-00	2
4	205025-0-12	1
5	202609-0-10	1
6	205011-0-10	1
7	202489-0-10	1
8	727021-0-00	1
9	745010-2-00	2
10	204947-0-10	1
11	204894-0-11	1
12	204895-0-11	1
13	204869-0-11	1
14	204878-0-11	1
15	741413-2-00	1
16	204889-0-10	1
17	765510-1-10	7
18	202488-0-10	1
19	205007-0-13	1
20	741531-2-00	2
21	209945-0-00	1
22	209278-0-00	1
23	740230-2-00	2
24	211310-0-00	1
25	209355-0-00	1
26	207020-2-01	2
27	209194-0-00	1
28	209264-0-10	1
29	209261-0-00	1
30	741538-2-00	1
31	207650-0-01	1
32	744573-0-00	1
33	207653-0-01	1
34	211137-0-00	1
35	207417-0-01	1
36	211247-0-00	1
37	211301-0-00	1

SEGUE  
FOLLOWS

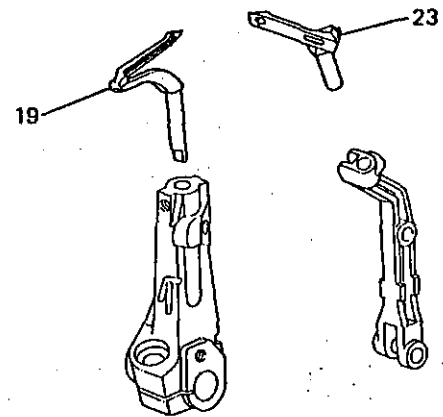
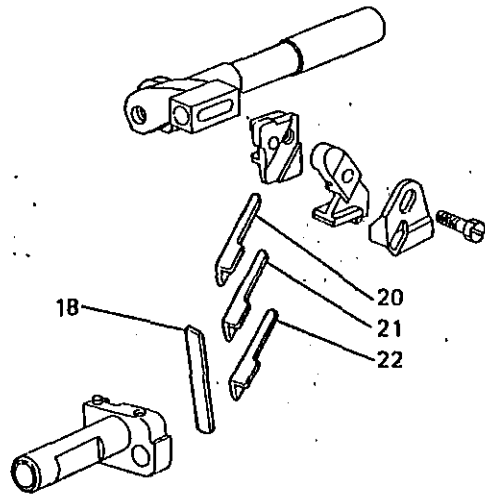
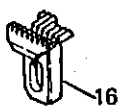
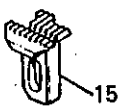
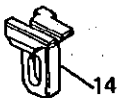
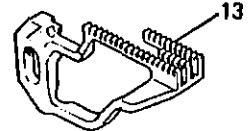
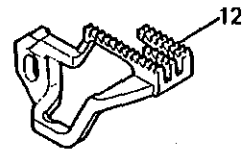
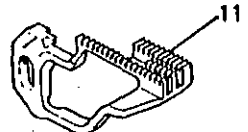
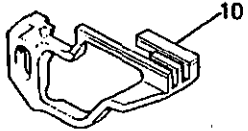
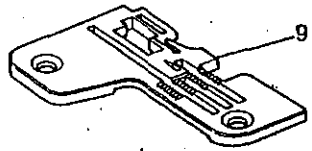
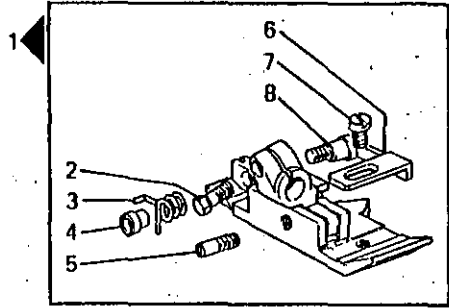

From the library of: Diamond Needle Corp

Fig. N.	Part. N. Piece N.	Qt.
1	207055-3-01	1
2	204947-0-10	1
3	204894-0-11	1
4	204895-0-11	1
5	204869-0-11	1
6	207053-0-01	1
7	741413-2-00	1
8	204889-0-10	1
9	207051-0-02	1
10	205009-2-12	1
11	205059-0-13	1
12	505060-0-13	1
13	207052-0-02	1
14	205013-2-11	1
15	205064-0-10	1
16	205065-0-10	1
17	205011-0-10	1
18	204693-0-01	2
19	209268-0-00	1
20	209356-0-00	1
21	209357-0-00	1
22	209358-0-00	2
23	211248-0-00	1

**CARATTERISTICHE E FUNZIONI DEI PARTICOLARI A RICHIESTA**  
**CHARACTERISTICS AND FUNCTIONS OF REQUESTED SPARE PARTS**  
**CHARACTERISTIQUES ET FONCTIONS DES REFERENCES SUR DEMANDE**  
**KENNZEICHEN UND FUNKTIONEN DER TEILE AUF ANFRAGE**  
**CARACTERISTICAS Y FUNCIONES DE LOS REPUESTOS POR SOLICITUD**

005/3

Fig. N.	X	Y	DESCRIZIONE	DESCRIPTION	DESCRIPTION	BENENNUNG	DESCRIPCION
1●			Per costa sopraggiunto da 2 mm.	For bight 2 mm.	Pour surjet de 2 mm.	Für Überwendlichkante von 2 mm.	Para ancho costura puntada de seguridad 2 mm.
9●	2						
10*		G					
11■		2					
12▲		2					
13●		1,5					
14*		G					
15■		2					
16▲		2					
17●		1,5	In dotazione.	Normal setting.	En dotation	Als Ausstattung.	En dotación.
18		A					
19			Crochet foro ø 0,7.	Looper hole ø 0,7.	Crochet trou ø 0,7.	Greifer Bohrung ø 0,7.	Garfio orificio ø 0,7.
20		A					
21		WD					
22		AD					
23			Crochet foro ø 0,7.	Looper hole ø 0,7.	Crochet trou ø 0,7.	Greifer Bohrung ø 0,7.	Garfio orificio ø 0,7.

From the library of: Diamond Needle Corp

X	-	LARGHEZZA COSTA	WIDTH OF BIGHT	LARGEUR DE SURJET	UEBERWENDLICHBREITE	ANCHO COSTURA
Y	-	PASSO/FINITURA	DISTANCE/FINISHING	PAS/FINITION	TEILUNG/BEHANDLUNG	PASO/ACABADO
A	-	ACCIAIO	STEEL	ACIER	STAHL	ACERO
D	-	DENTATO	TOOTHED	DENTE	GEZAEHNT	DENTADO
G	-	GOMMATA	RUBBERED	CAOUTCHOUTEE	GUMMIBELEGTEN	ENGOMADO
W	-	WIDIA	WIDIA	WIDIA	WIDIA	WIDIA
* ▲ ■ ●	-	ABBINAMENTI OBBLIGATORI	FIXED COUPLINGS	JUMELAGES OBLIGES	PFLICHT KOPPELUNGEN	COMBINACIONES OBLIGATORIAS

1

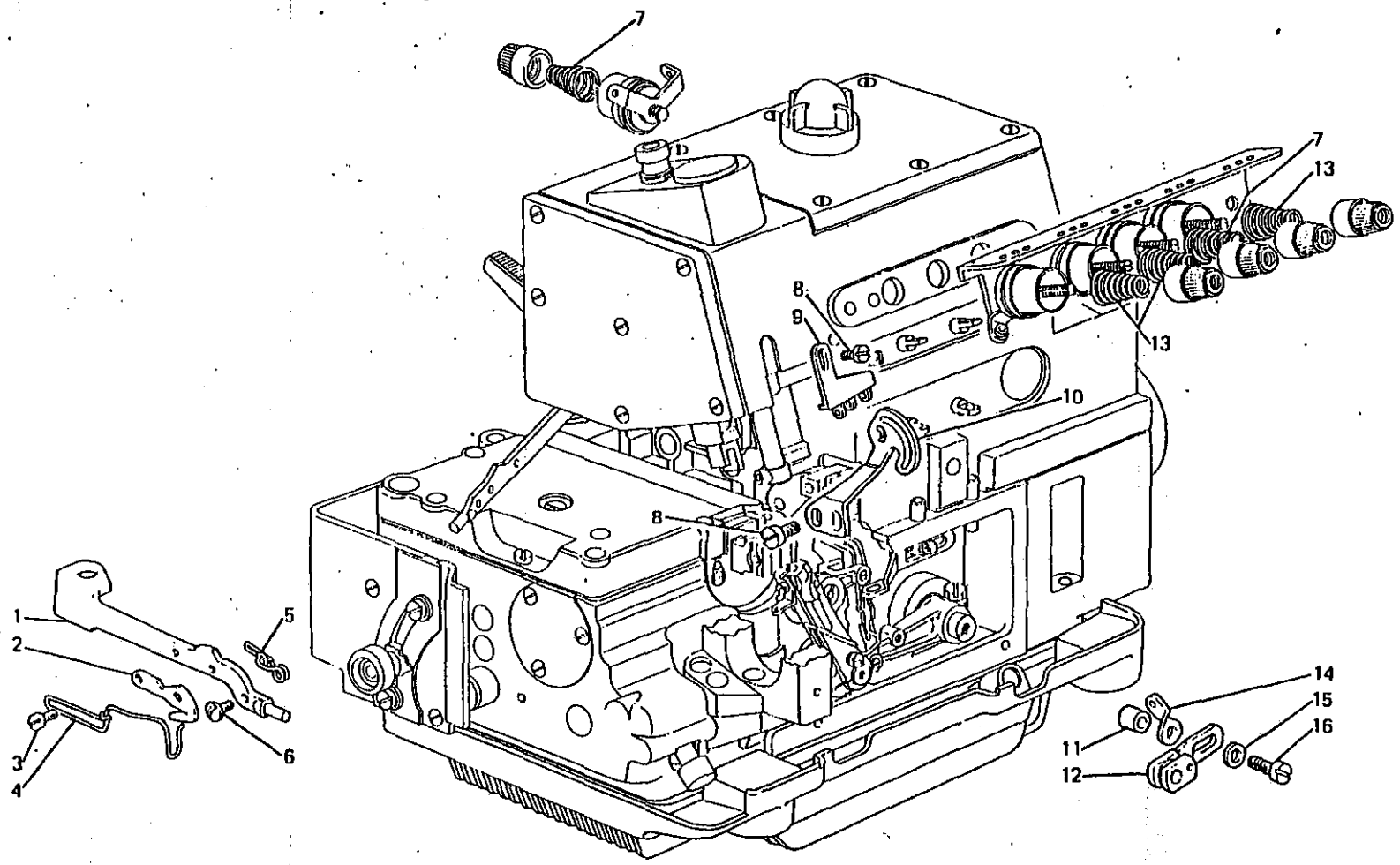

Flg. N.	Part. N. Piece N.	Qt.
1	209511-0-00	1
2	202194-0-11	1
3	741433-2-00	2
4	991812-0-00	1
5	205042-0-20	1
6	203187-0-10	1
7	202681-0-10	2
8	741558-0-00	3
9	211144-0-00	1
10	211146-0-00	1
11	211742-0-00	1
12	211743-0-00	1
13	202227-0-10	3
14	211748-0-00	1
15	704104-2-00	1
16	722440-2-00	1

From the library of: Diamond Needle Corp

SEGUE  
FOLLOWS

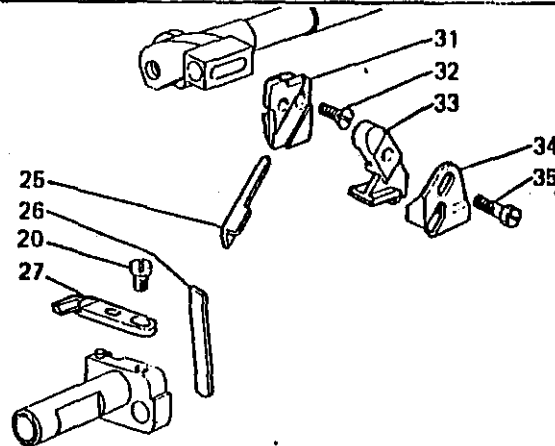
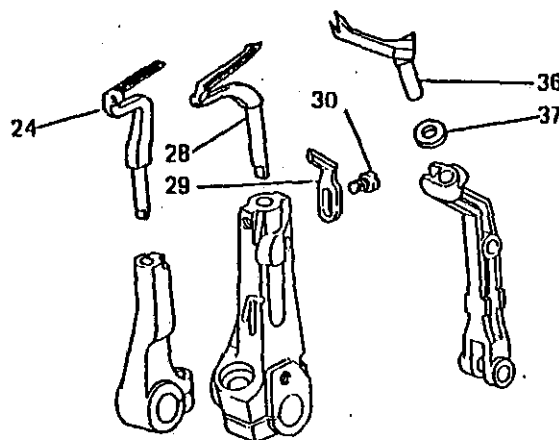
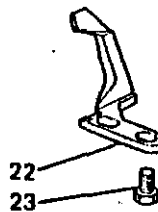
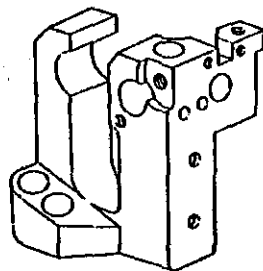
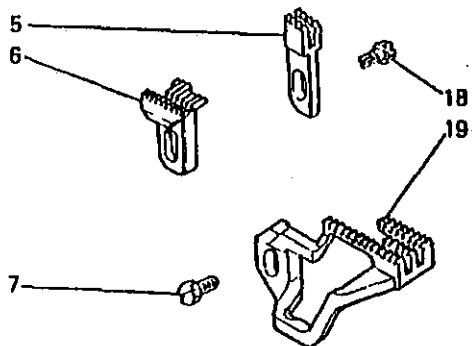
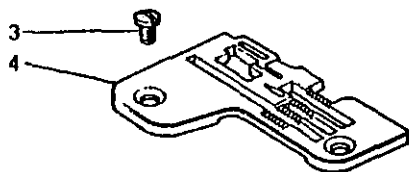
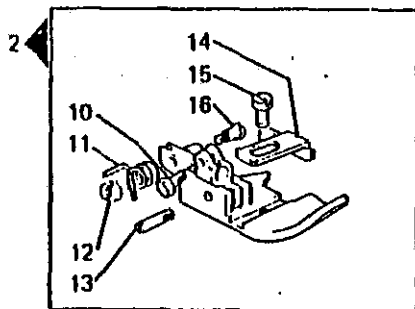
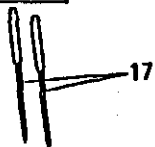
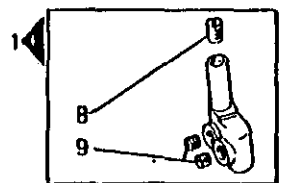

From the library of: Diamond Needle Corp

Qty N.	Part N. Piece N.	Qt.
1	207526-2-00	1
2	205118-3-12	1
3	744742-2-00	2
4	205025-0-12	1
5	202609-0-10	1
6	205065-0-10	1
7	202489-0-10	1
8	727021-0-00	1
9	745810-2-00	2
10	204947-0-10	1
11	204894-0-11	1
12	204895-0-11	1
13	204869-0-11	1
14	204878-0-11	1
15	741413-2-00	1
16	204889-0-10	1
17	765510-1-10	7
18	202488-0-10	1
19	205060-0-13	1
20	741531-2-00	2
21	209945-0-00	1
22	209279-0-00	1
23	740230-2-00	2
24	211310-0-00	1
25	209355-0-00	1
26	207020-2-01	1
27	209194-0-00	1
28	209264-0-10	1
29	209261-0-00	1
30	741538-2-00	1
31	207650-0-01	1
32	744573-0-00	1
33	207653-0-01	1
34	211137-0-00	1
35	207417-0-01	1
36	211247-0-00	1
37	211301-0-00	1

SEGUE  
FOLLOWS



**CARATTERISTICHE E FUNZIONI DEI PARTICOLARI A RICHIESTA**  
**CHARACTERISTICS AND FUNCTIONS OF REQUESTED SPARE PARTS**  
**CARACTERISTIQUES ET FONCTIONS DES REFERENCES SUR DEMANDE**  
**KENNZEICHEN UND FUNKTIONEN DER TEILE AUF ANFRAGE**  
**CARACTERISTICAS Y FUNCIONES DE LOS REPUESTOS POR SOLICITUD**

006/3

Fig. N.	X	Y	DESCRIZIONE	DESCRIPTION	DESCRIPTION	BENENNUNG	DESCRIPCION
1		1,5					
2*		G					
3●		2					
4		1,5					
5*		G					
6●		2					
7		A					
8		W	Crochet foro ø 0,7.	Looper hole ø 0,7.	Crochet trou ø 0,7.	Greifer Bohrung ø 0,7.	Garfio orificio ø 0,7.
9		WD					
10		AD					
11							
12			Crochet foro ø 0,7.	Looper hole ø 0,7.	Crochet trou ø 0,7.	Greifer Bohrung ø 0,7.	Garfio orificio ø 0,7.

From the library of: Diamond Needs Corp

X	-	LARGHEZZA COSTA	WIDTH OF BIGHT	LARGEUR DE SURJET	UEBERWENDLICHBREITE	ANCHO COSTURA
Y	-	PASSO/FINITURA	DISTANCE/FINISHING	PAS/FINITION	TEILUNG/BEHANDLUNG	PASO/ACABADO
A	-	ACCIAIO	STEEL	ACIER	STAHL	ACERO
D	-	DENTATO	TOOTHED	DENTE	GEZAEHNT	DENTADO
G	-	GOMMATA	RUBBERED	CAOUTCHOUTEE	GUMMIBELEGTEN	ENGOMADO
W	-	WIDIA	WIDIA	WIDIA	WIDIA	WIDIA
* ▲ ■ ●	-	ABBINAMENTI OBBLIGATORI	FIXED COUPLINGS	JUMELAGES OBLIGES	PFLICHT KOPPELUNGEN	COMBINACIONES OBLIGATORIAS

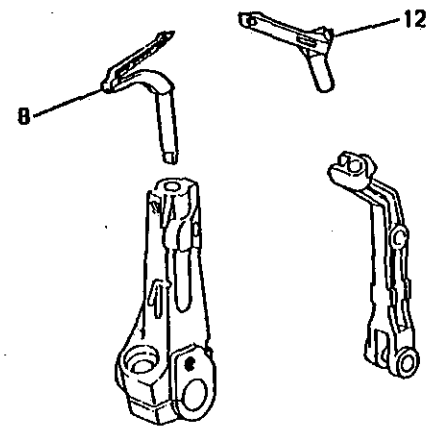
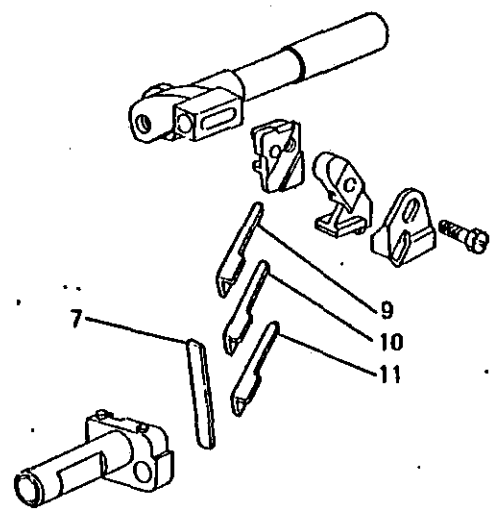
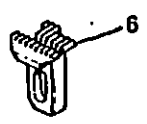
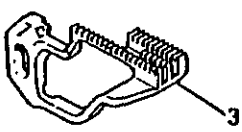
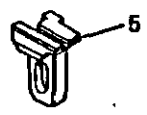
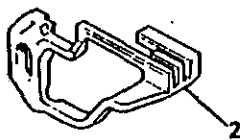
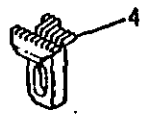
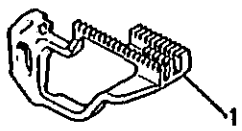

From the library of: Diamond Needle Corp.

Fig. N.	Part N. Piece N.	Qt.
1	205007-0-13	1
2	205009-2-12	1
3	205059-0-13	1
4	205011-0-10	1
5	205013-2-11	1
6	205064-0-10	1
7	204693-0-11	1
8	209268-0-00	1
9	209356-0-00	2
10	209357-0-00	1
11	209358-0-00	2
12	211248-0-00	1

SEQUE  
FOLLOWS

**CARATTERISTICHE E FUNZIONI DEI PARTICOLARI A RICHIESTA**  
**CHARACTERISTICS AND FUNCTIONS OF REQUESTED SPARE PARTS**  
**CARACTERISTIQUES ET FONCTIONS DES REFERENCES SUR DEMANDE**  
**KENNZEICHEN UND FUNKTIONEN DER TEILE AUF ANFRAGE**  
**CARACTERISTICAS Y FUNCIONES DE LOS REPUESTOS POR SOLICITUD**

006/4

Fig. N.	X	Y	DESCRIZIONE	DESCRIPTION	DESCRIPTION	BENENNUNG	DESCRIPCION
1			Guida ribaltabile per limitare l'altezza del taglio	Folder for limiting cutting thickness.	Guide escamotable pour limiter la hauteur de coupe.	Klappführung um die Schneidhöhe zu begrenzen.	Guía volcable para limitar la altura del corte.

From the library of: Diamond Needle Corp

X	-	LARGHEZZA COSTA	WIDTH OF BIGHT	LARGEUR DE SURJET	UEBERWENDLICHBREITE	ANCHO COSTURA
Y	-	PASSO/FINITURA	DISTANCE/FINISHING	PAS/FINITION	TEILUNG/BEHANDLUNG	PASO/ACABADO
A	-	ACCIAIO	STEEL	ACIER	STAHL	ACERO
D	-	DENTATO	TOOTHED	DENTE	GEZAEHNT	DENTADO
G	-	GOMMATA	RUBBERED	CAOUTCHOUTEE	GUMMIBELAGTEN	ENGOMADO
W	-	WIDIA	WIDIA	WIDIA	WIDIA	WIDIA
* ▲ ■ ●	-	ABBINAMENTI OBBLIGATORI	FIXED COUPLINGS	JUMELAGES OBLIGES	PFLICHT KOPPELUNGEN	COMBINACIONES OBLIGATORIAS

Fig. N.	Part N. / Piece N.	Qt.
1	204919-4-11	1
2	204960-4-00	1
3	201236-0-10	2
4	204920-0-20	1
5	743464-2-00	1
6	702406-0-00	1
7	204647-0-00	1
8	744730-2-00	1
9	300710-0-10	1
10	202970-0-20	1
11	746007-2-00	1
12	729013-2-00	1

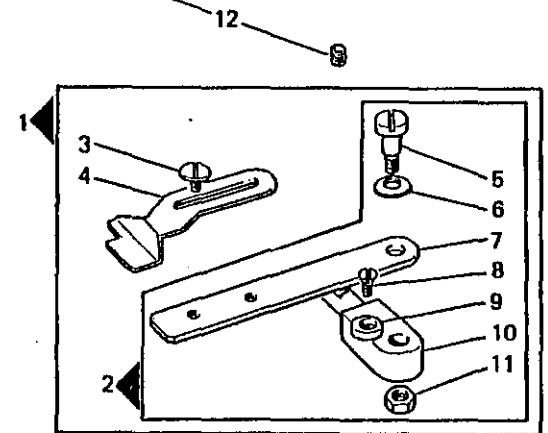
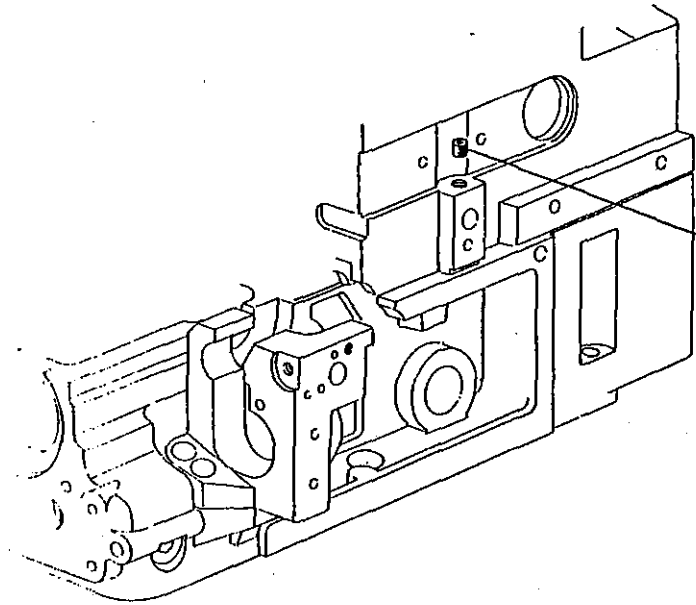

From the library of: Diamond Needle Corp

1

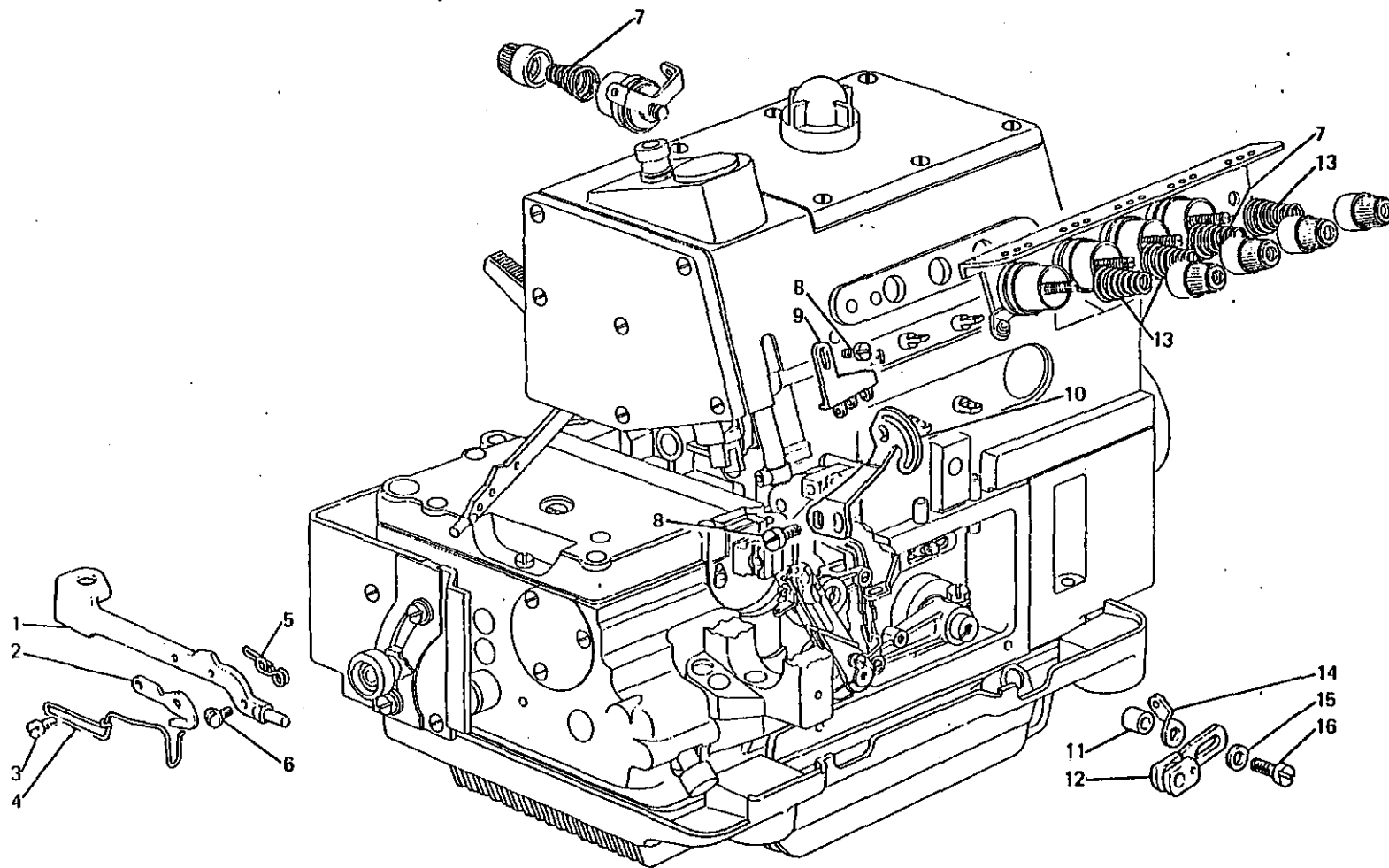
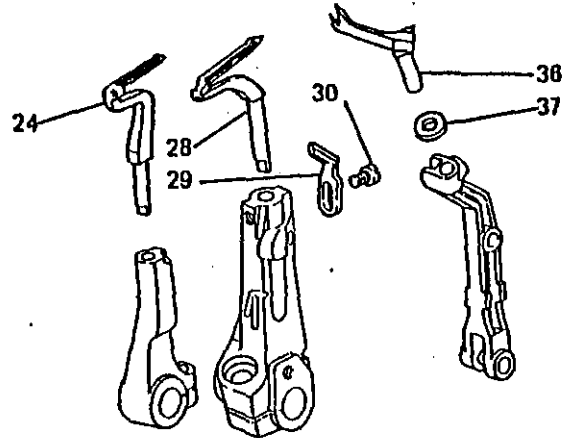
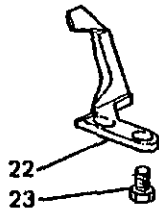
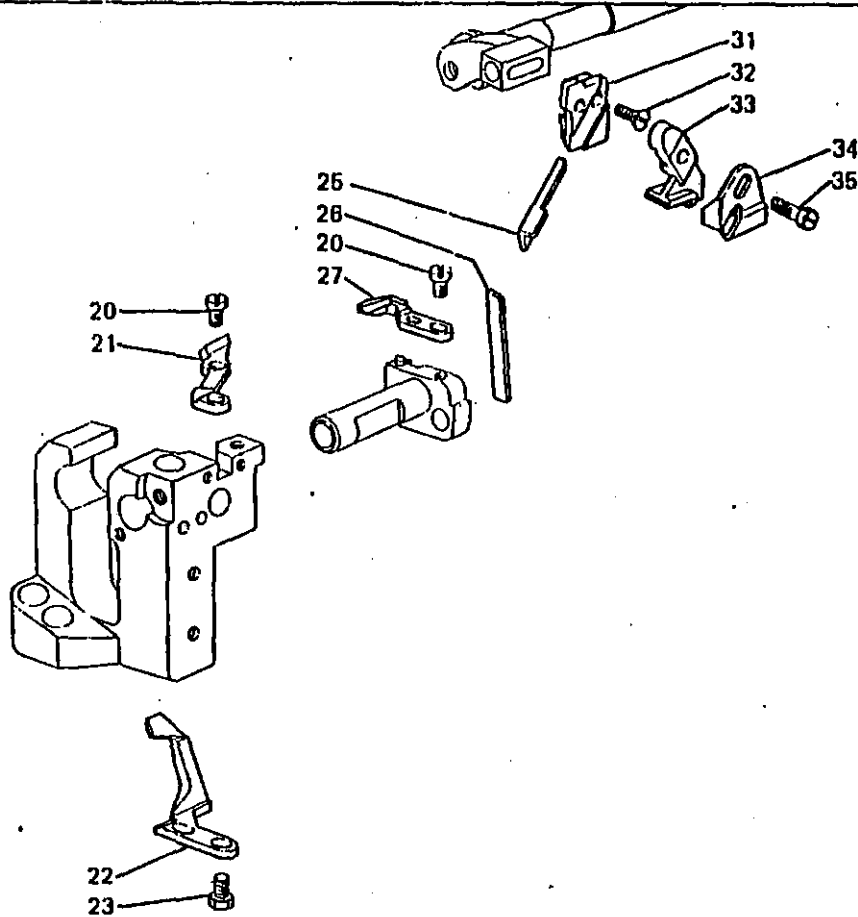
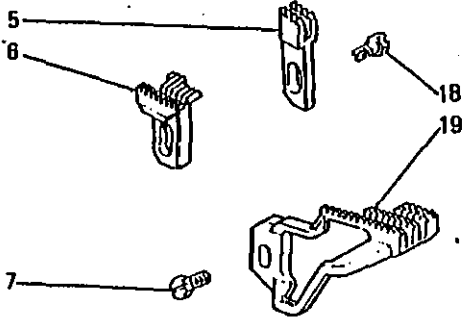
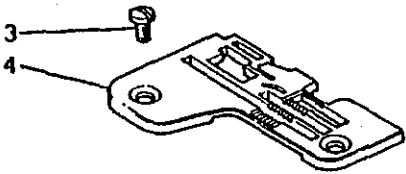
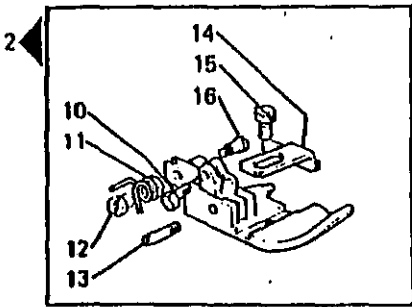
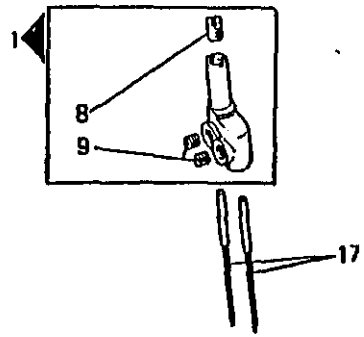

Fig. N.	Part. N. Piece N.	Qt.
1	209511-0-00	1
2	202194-0-11	1
3	741433-2-00	2
4	991612-0-00	1
5	204891-0-20	1
6	203187-0-10	1
7	202681-0-10	2
8	741558-0-00	3
9	211143-0-00	1
10	211146-0-00	1
11	211742-0-00	1
12	211743-0-00	1
13	202227-0-10	3
14	211748-0-00	1
15	704104-2-00	1
16	722440-2-00	1

From the library of: Diamond Needle Corp.

SEGUE  
FOLLOWS



From the library of: Diamond Needle Corp

Fig. N.	Part N. Piece It.	Qt.
1	207524-2-00	1
2	206002-3-02	1
3	744742-2-00	2
4	204864-0-13	1
5	202609-0-10	1
6	204943-0-11	1
7	202489-0-10	1
8	727021-0-00	1
9	745810-2-00	2
10	204947-0-10	1
11	204894-0-11	1
12	204895-0-11	1
13	204869-0-11	1
14	204878-0-11	1
15	741413-2-00	1
16	204883-0-10	1
17	765510-1-10	7
18	202408-0-10	1
19	204941-0-13	1
20	741531-2-00	2
21	209192-0-00	1
22	209279-0-00	1
23	740230-2-00	2
24	211310-0-00	1
25	209355-0-00	1
26	207020-2-01	2
27	209195-0-00	1
28	209264-0-10	1
29	209261-0-00	1
30	741538-2-00	1
31	207650-0-01	1
32	744573-0-00	1
33	207653-0-01	1
34	211137-0-00	1
35	207417-0-01	1
36	211247-0-00	1
37	211301-0-00	1

SEGUE  
FOLLOWS

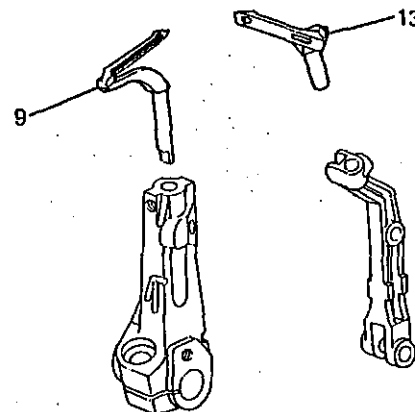
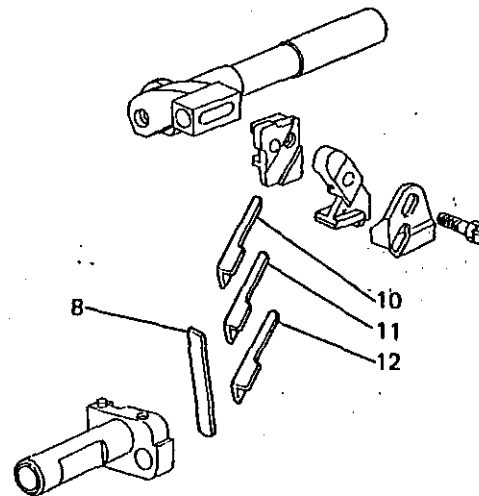
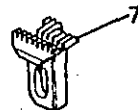
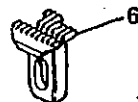
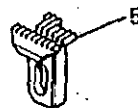
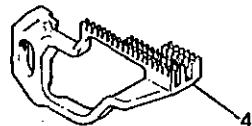
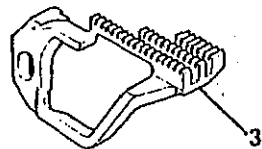
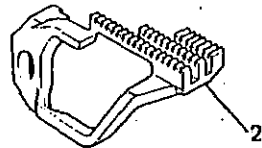
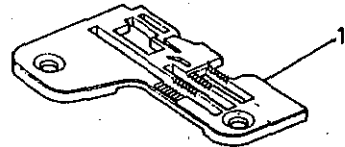

From the library of: Diamond Needle Corp.

Fig. N.	Part. N. Piece N.	Qt.
1	204948-0-13	1
2	204846-0-13	1
3	204940-0-13	1
4	204997-0-01	1
5	204850-0-10	1
6	204942-0-10	1
7	204851-0-11	1
8	204693-0-11	1
9	209268-0-00	1
10	209356-0-00	2
11	209357-0-00	1
12	209358-0-00	2
13	211248-0-00	1

**CARATTERISTICHE E FUNZIONI DEI PARTICOLARI A RICHIESTA**  
**CHARACTERISTICS AND FUNCTIONS OF REQUESTED SPARE PARTS**  
**CARACTERISTIQUES ET FONCTIONS DES REFERENCES SUR DEMANDE**  
**KENNZEICHEN UND FUNKTIONEN DER TEILE AUF ANFRAGE**  
**CARACTERISTICAS Y FUNCIONES DE LOS REPUESTOS POR SOLICITUD**

007/3

Fig. N.	X	Y	DESCRIZIONE	DESCRIPTION	DESCRIPTION	BENENNUNG	DESCRIPCION
1	4						
2		1,5					
3●		2					
4▲		1,5					
5		1,5					
6●		2					
7▲		1,5					
8		A					
9		A	Crochet foro ø 0,7.	Looper hole ø 0,7.	Crochet trou ø 0,7.	Greller Bohrung ø 0,7.	Garfio orificio ø 0,7.
10		A					
11		WD					
12		AD					
13			Crochet foro ø 0,7.	Looper hole ø 0,7.	Crochet trou ø 0,7.	Greifer Bohrung ø 0,7.	Garfio orificio ø 0,7.

From the library of: Diamond Needle Co.

- |         |   |                         |                    |                   |                     |                            |
|---------|---|-------------------------|--------------------|-------------------|---------------------|----------------------------|
| X       | - | LARGHEZZA COSTA         | WIDTH OF BIGHT     | LARGEUR DE SURJET | UEBERWENDLICHBREITE | ANCHO COSTURA              |
| Y       | - | PASSO/FINITURA          | DISTANCE/FINISHING | PAS/FINITION      | TEILUNG/BEHANDLUNG  | PASO/ACABADO               |
| A       | - | ACCIAIO                 | STEEL              | ACIER             | STAHL               | ACERO                      |
| D       | - | DENTATO                 | TOOTHED            | DENTE             | GEZAEHNT            | DENTADO                    |
| G       | - | GOMMATA                 | RUBBERED           | CAOUTCHOUTEE      | GUMMIBELEGTEN       | ENGOMADO                   |
| W       | - | WIDIA                   | WIDIA              | WIDIA             | WIDIA               | WIDIA                      |
| * ▲ ■ ● | - | ABBINAMENTI OBBLIGATORI | FIXED COUPLINGS    | JUMELAGES OBLIGES | PFLICHT KOPPELUNGEN | COMBINACIONES OBLIGATORIAS |



1

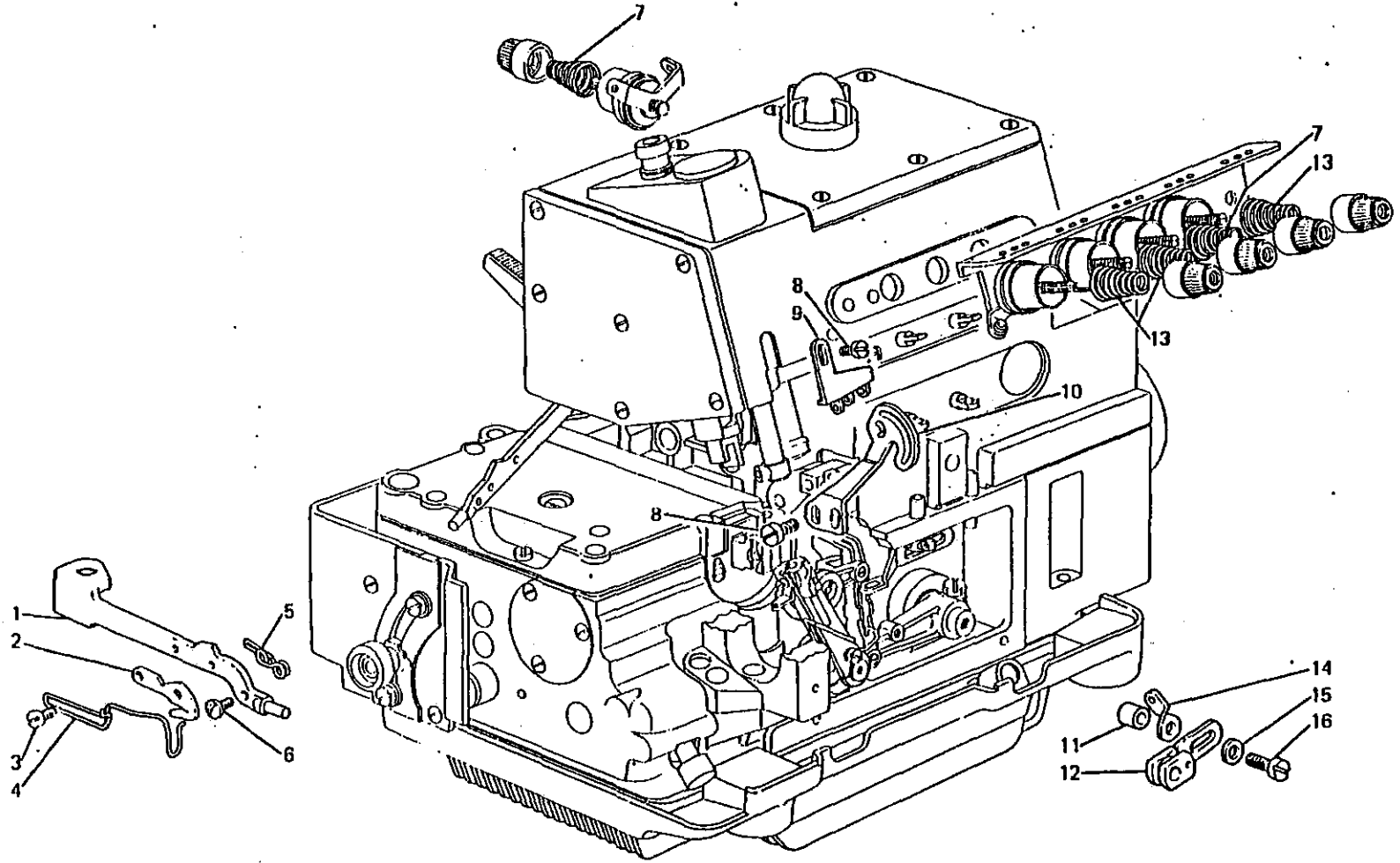
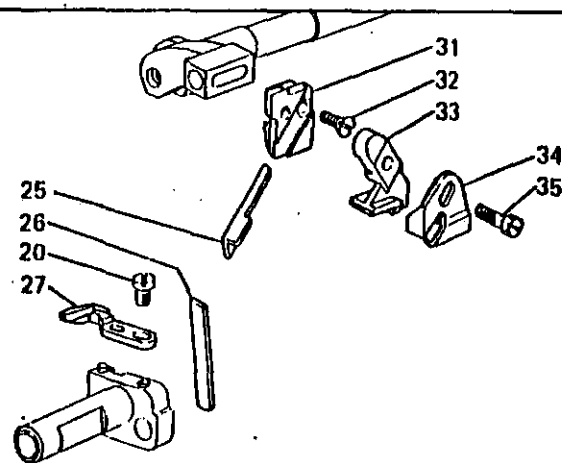
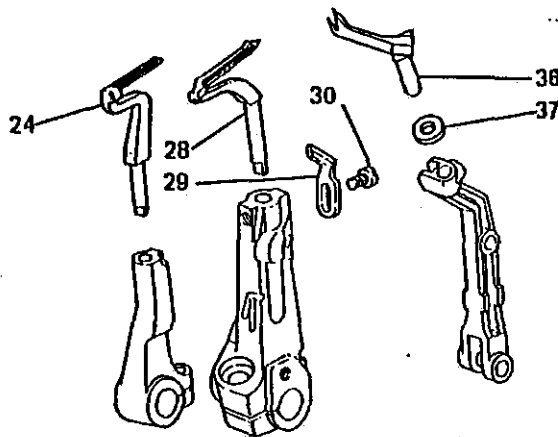
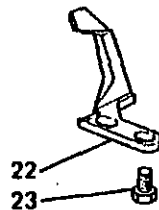
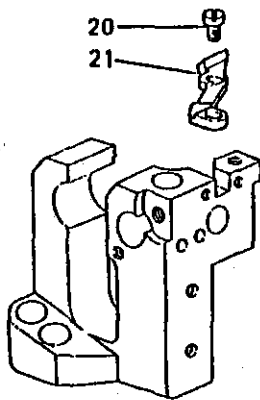
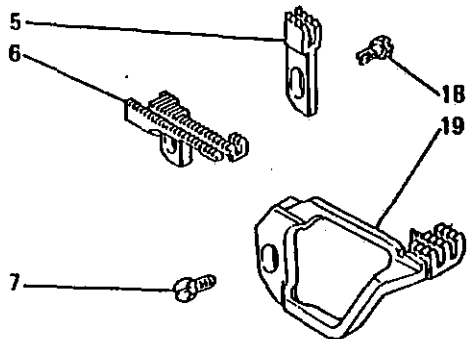
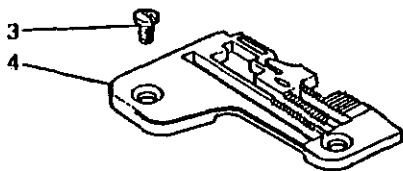
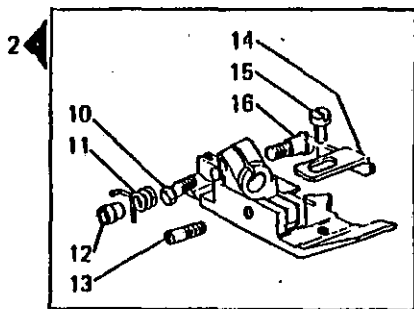
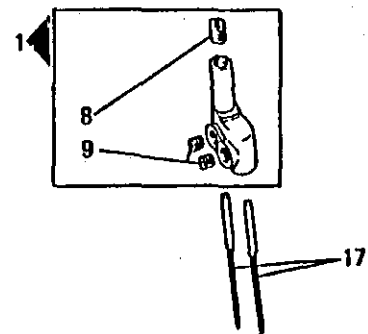

Fig. N.	Part N. / Piece N.	Qt.
1	209511-0-00	1
2	202194-0-11	1
3	741433-2-00	2
4	991612-0-00	1
5	204891-0-20	1
6	203187-0-10	1
7	202681-0-10	2
8	741558-0-00	3
9	211143-0-00	1
10	211146-0-00	1
11	211742-0-00	1
12	211743-0-00	1
13	202227-0-10	3
14	211748-0-00	1
15	704104-2-00	1
16	722440-2-00	1

From the library of: Diamond Needle Corp

SEGUE  
FOLLOWS



From the library of: Diamond Needle Corp

Fig. N.	Part N. Piece N.	Qt.
1	207524-2-00	1
2	204950-3-12	1
3	744742-2-00	2
4	208043-0-02	1
5	202609-0-10	1
6	208053-0-10	1
7	202489-0-10	1
8	727021-0-00	1
9	745810-2-00	2
10	204947-0-10	1
11	204894-0-11	1
12	204895-0-11	1
13	204869-0-11	1
14	204876-0-11	1
15	741413-2-00	1
16	204889-0-10	1
17	765510-1-90	7
18	202488-0-10	1
19	208042-0-10	1
20	741531-2-00	2
21	209192-0-00	1
22	209279-0-00	1
23	740230-2-00	2
24	211310-0-00	1
25	209356-0-00	2
26	204693-0-11	2
27	209195-0-00	1
28	209264-0-10	1
29	209281-0-00	1
30	741538-2-00	1
31	207650-0-01	1
32	744573-0-00	1
33	207653-0-01	1
34	211137-0-00	1
35	207417-0-01	1
36	211247-0-00	1
37	211301-0-00	1

SEGUE  
FOLLOWS

**CARATTERISTICHE E FUNZIONI DEI PARTICOLARI A RICHIESTA**  
**CHARACTERISTICS AND FUNCTIONS OF REQUESTED SPARE PARTS**  
**CARACTERISTIQUES ET FONCTIONS DES REFERENCES SUR DEMANDE**  
**KENNZEICHEN UND FUNKTIONEN DER TEILE AUF ANFRAGE**  
**CARACTERISTICAS Y FUNCIONES DE LOS REPUESTOS POR SOLICITUD**

008/3

Fig. N.	X	Y	DESCRIZIONE	DESCRIPTION	DESCRIPTION	BENENNUNG	DESCRIPCION
1	4,5						
2 ●		1,5					
3 ●		1,5					
4		W					
5			Crochet foro ø 0,7.	Looper hole ø 0,7.	Crochet trou ø 0,7.	Greifer Bohrung ø 0,7.	Garfo orificio ø 0,7.
6		W					
7		WD					
8		AD					
9			Crochet foro ø 0,7.	Looper hole ø 0,7.	Crochet trou ø 0,7.	Greifer Bohrung ø 0,7.	Garfo orificio ø 0,7.

From the library of: Diamond Needle Corp

X	=	LARGHEZZA COSTA	WIDTH OF BIGHT	LARGEUR DE SURJET	UEBERWENDLICHBREITE	ANCHO COSTURA
Y	=	PASSO/FINITURA	DISTANCE/FINISHING	PAS/FINITION	TEILUNG/BEHANDLUNG	PASO/ACABADO
A	=	ACCIAIO	STEEL	ACIER	STAHL	ACERO
D	=	DENTATO	TOOTHED	DENTE	GEZAEHNT	DENTADO
G	=	GOMMATA	RUBBERED	CAOUTCHOUTEE	GUMMIBELEGTEN	ENGOMADO
W	=	WIDIA	RUBBERED	WIDIA	WIDIA	WIDIA
* ▲ ■ ●	=	ABBINAMENTI OBBLIGATORI	FIXED COUPLINGS	JUMELAGES OBLIGES	PFLICHT KOPPELUNGEN	COMBINACIONES OBLIGATORIAS

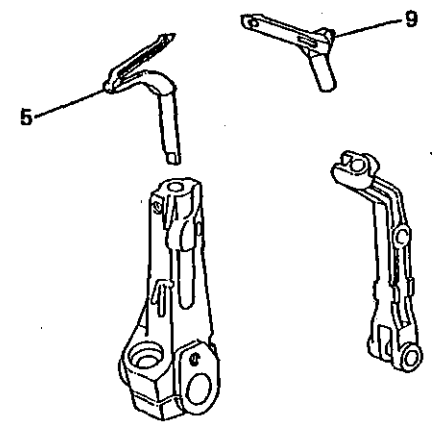
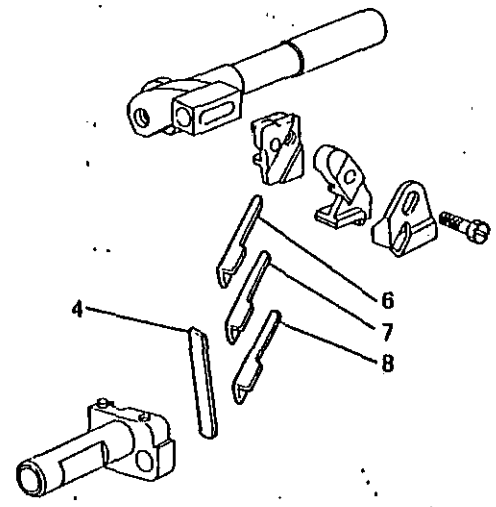
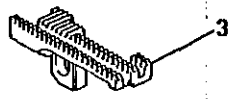
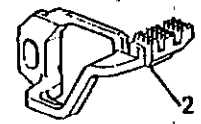
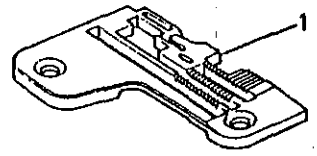

From the library of: Diamond Needle Corp.

Fig. N.	Part N. Pièce N.	Qt.
1	208045-0-02	1
2	208044-0-10	1
3	208054-0-10	1
4	207020-2-01	1
5	209268-0-00	1
6	209355-0-00	1
7	209357-0-00	1
8	209358-0-00	2
9	211248-0-00	1

1

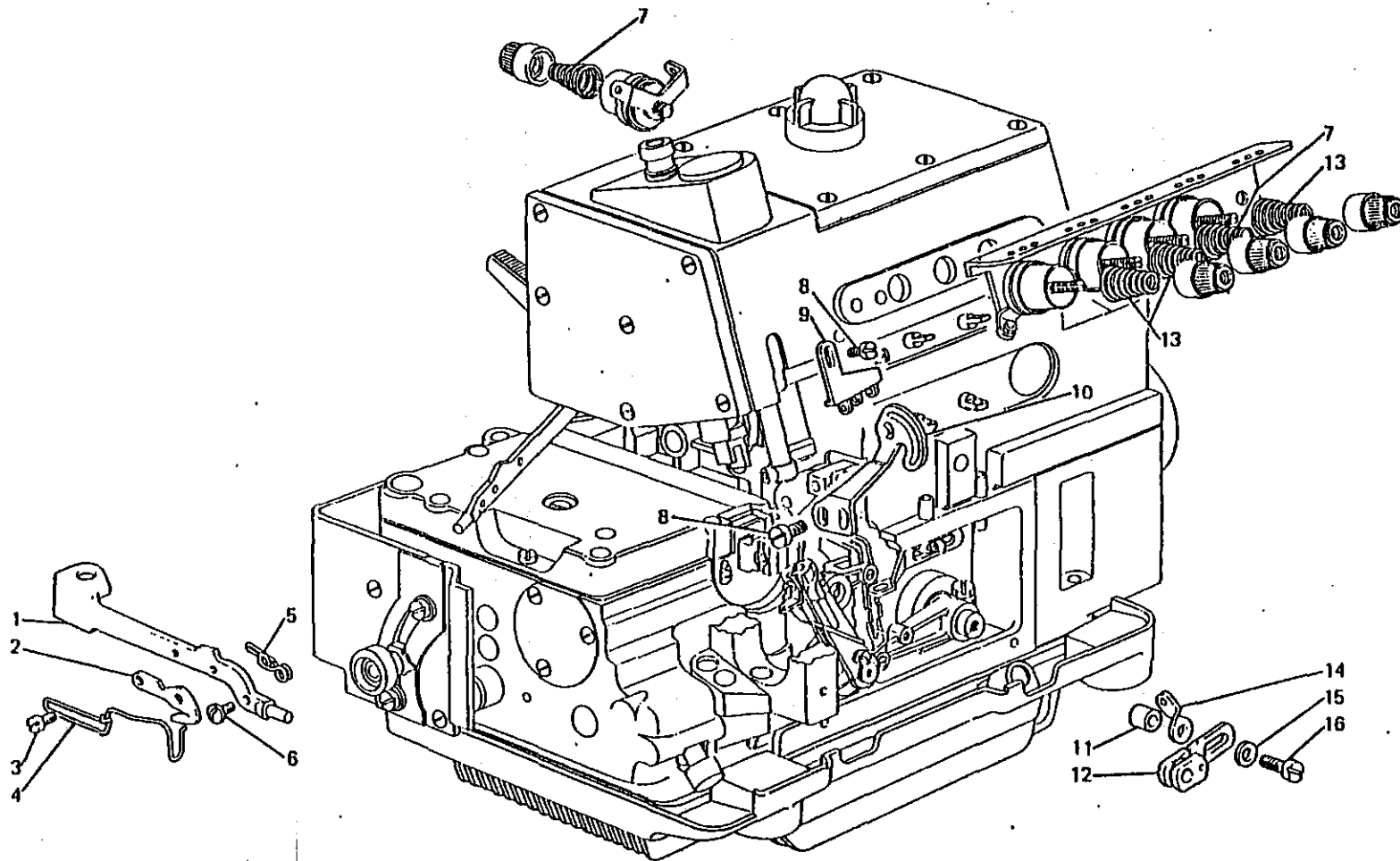
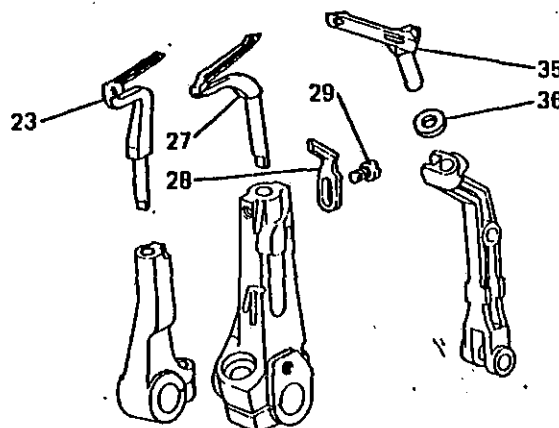
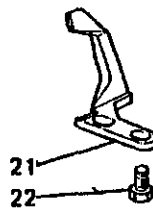
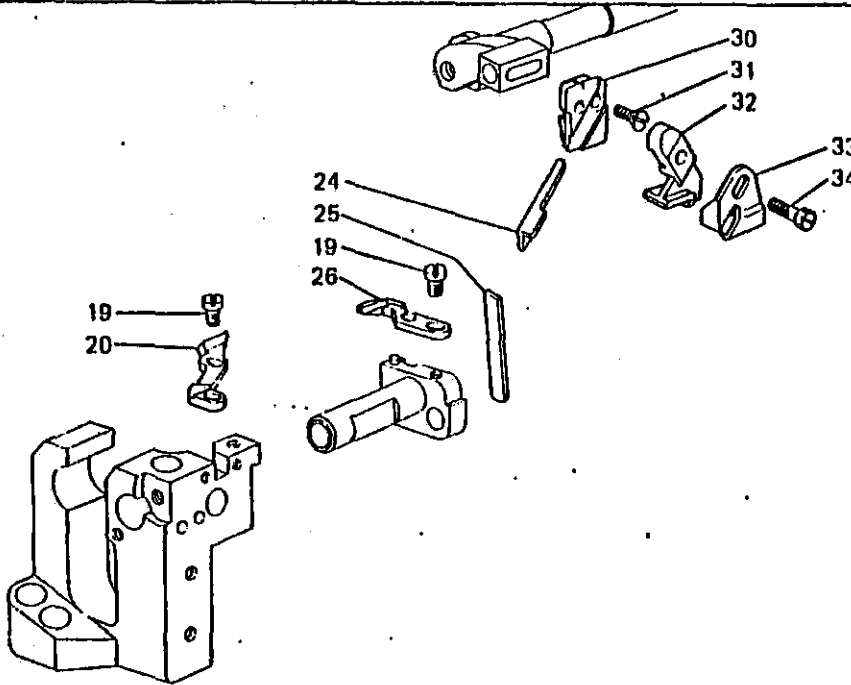
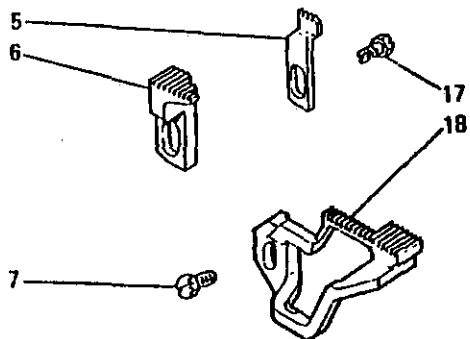
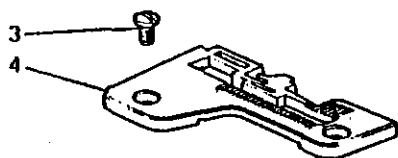
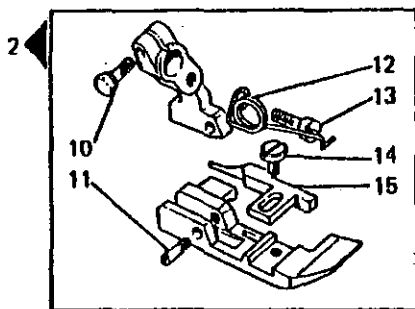
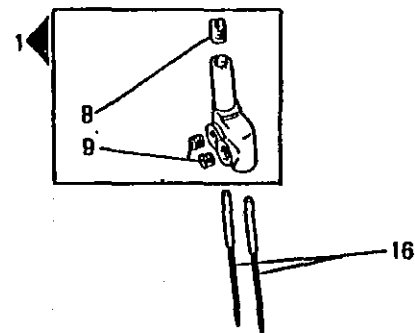

Fig. N.	Part N. Piece N.	Qn.
1	209512-0-00	1
2	202194-0-11	1
3	741433-2-00	2
4	991612-0-00	1
5	204891-0-20	1
6	203187-0-10	1
7	202681-0-10	2
8	741658-0-00	3
9	211143-0-00	1
10	211146-0-00	1
11	211742-0-00	1
12	211743-0-00	1
13	202227-0-10	3
14	211748-0-00	1
15	704104-2-00	1
16	722440-2-00	1

From the library of: Diamond Needle Corp

•SEGUE  
FOLLOWS



From the library of: Diamond Needle Corp

Fig. N.	Part. N. Piece N.	Qt.
1	207747-2-00	1
2	205824-3-10	1
3	744742-2-00	2
4	205816-0-00	1
5	205830-0-00	1
6	205818-0-00	1
7	202489-0-10	1
8	727021-0-00	1
9	745810-2-00	2
10	204947-0-10	1
11	207749-0-00	1
12	205822-0-00	1
13	741654-2-00	1
14	721411-2-00	1
15	205820-0-10	1
16	765510-1-80	7
17	202468-0-10	1
18	205817-0-01	1
19	741531-2-00	2
20	209192-0-00	1
21	209279-0-00	1
22	740230-2-00	2
23	211310-0-00	1
24	209356-0-00	1
25	204693-0-11	1
26	209188-0-00	1
27	209264-0-10	1
28	209261-0-00	1
29	741538-2-00	1
30	207650-0-01	1
31	744573-0-00	1
32	207653-0-01	1
33	211137-0-00	1
34	207417-0-01	1
35	211248-0-00	1
36	211301-0-00	1

SEGUE  
FOLLOWS

**CARATTERISTICHE E FUNZIONI DEI PARTICOLARI A RICHIESTA**  
**CHARACTERISTICS AND FUNCTIONS OF REQUESTED SPARE PARTS**  
**CARACTERISTIQUES ET FONCTIONS DES REFERENCES SUR DEMANDE**  
**KENNZEICHEN UND FUNKTIONEN DER TEILE AUF ANFRAGE**  
**CARACTERISTICAS Y FUNCIONES DE LOS REPUESTOS POR SOLICITUD**

009/3

Fig. N.	X	Y	DESCRIZIONE	DESCRIPTION	DESCRIPTION	BENENNUNG	DESCRIPCION
1 ●			Per tessuti leggeri (Camiceria)	For light fabrics (Shirts)	Pour tissus léger (Chemiserie)	Für leicht Stoffe (Hemden)	Para tejidos ligero (Camiseria)
2 ▲			Per tessuti leggeri (Camiceria)	For light fabrics (Shirts)	Pour tissus léger (Chemiserie)	Für leicht Stoffe (Hemden)	Para tejidos ligero (Camiseria)
10 ▲	5,5						
11 ●	4,5						
12		W	Crochet loto ø 0,7.	Looper hole ø 0,7.	Crochet trou ø 0,7.	Greifer Bohrung ø 0,7.	Garfo orlido ø 0,7.
13		W					
14		WD					
15		AD					
16			Crochet cieco.	Blind looper.	Crochet aveugle.	Blindgreifer.	Garfo ciego.
17							

From the library of Diamond Needle Corp

X	=	LARGHEZZA COSTA	WIDTH OF BIGHT	LARGEUR DE SURJET	UEBERWENDLICHBREITE	ANCHO COSTURA
Y	=	PASSO/FINITURA	DISTANCE/FINISHING	PAS/FINITION	TEILUNG/BEHANDLUNG	PASO/ACABADO
A	=	ACCIAIO	STEEL	ACIER	STAHL	ACERO
D	=	DENTATO	TOOTHED	DENTE	GEZAEHNT	DENTADO
G	=	GOMMATA	RUBBERED	CAOUTCHOUTEE	GUMMIBELEGTEN	ENGOMADO
W	=	WIDIA	WIDIA	WIDIA	WIDIA	WIDIA
* ▲ ●	=	ABBINAMENTI OBBLIGATORI	FIXED COUPLINGS	JUMELAGES OBLIGES	PFLICHT KOPPELUNGEN	COMBINACIONES OBLIGATORIAS

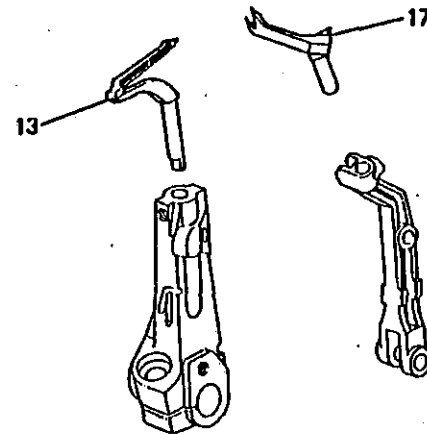
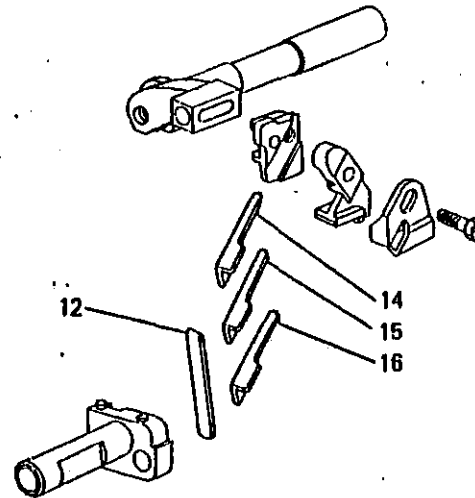
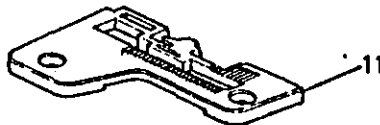
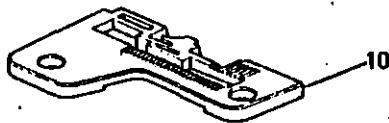
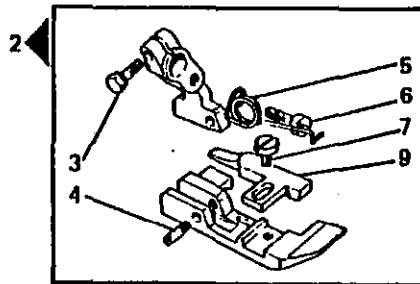
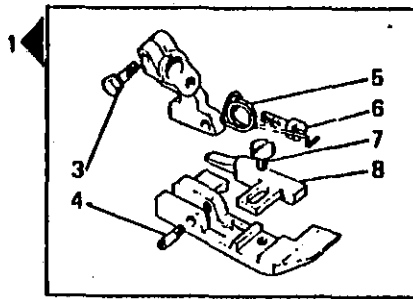

Fig. N.	Part N.	Qt.
1	205133-3-00	1
2	205814-3-10	1
3	204647-0-10	2
4	207749-0-00	2
5	205822-0-00	2
6	741854-2-00	2
7	721411-2-00	2
8	205834-0-00	1
9	205813-0-10	1
10	205815-0-00	1
11	205832-0-00	1
12	207020-2-01	1
13	209268-0-00	1
14	209355-0-00	1
15	209357-0-00	1
16	209358-0-00	2
17	211247-0-00	1

From the library of: Diamond Needle Corp

SEGUE  
FOLLOWS



**CARATTERISTICHE E FUNZIONI DEI PARTICOLARI A RICHIESTA**  
**CHARACTERISTICS AND FUNCTIONS OF REQUESTED SPARE PARTS**  
**CARACTERISTIQUES ET FONCTIONS DES REFERENCES SUR DEMANDE**  
**KENNZEICHEN UND FUNKTIONEN DER TEILE AUF ANFRAGE**  
**CARACTERISTICAS Y FUNCIONES DE LOS REPUESTOS POR SOLICITUD**

009/4

Fig. N.	X	Y	DESCRIZIONE	DESCRIPTION	DESCRIPTION	BENENNUNG	DESCRIPCION
1			Guida ribaltabile per limitare l'altezza del taglio	Folder for limiting cutting thickness.	Guide escamotable pour limiter la hauteur de coupe.	Klappführung um die Schneidehöhe zu begrenzen.	Gula volcable para limitar la altura del corte.

From the library of: Diamond Needle Corp

- |         |   |                         |                    |                   |                     |                            |
|---------|---|-------------------------|--------------------|-------------------|---------------------|----------------------------|
| X       | = | LARGHEZZA COSTA         | WIDTH OF BIGHT     | LARGEUR DE SURJET | UEBERWENDLICHBREITE | ANCHO COSTURA              |
| Y       | = | PASSO/FINITURA          | DISTANCE/FINISHING | PAS/FINITION      | TEILUNG/BEHANDLUNG  | PASO/ACABADO               |
| A       | = | ACCIAIO                 | STEEL              | ACIER             | STAHL               | ACERO                      |
| D       | = | DENTATO                 | TOOTHED            | DENTE             | GEZAEHNT            | DENTADO                    |
| G       | = | GOMMATA                 | RUBBERED           | CAOUTCHOUTEE      | GUMMIBELEGTEN       | ENGOMADO                   |
| W       | = | WIDIA                   | WIDIA              | WIDIA             | WIDIA               | WIDIA                      |
| * ▲ ■ ● | = | ABBINAMENTI OBBLIGATORI | FIXED COUPLINGS    | JUMELAGES OBLIGES | PFLICHT KOPPELUNGEN | COMBINACIONES OBLIGATORIAS |

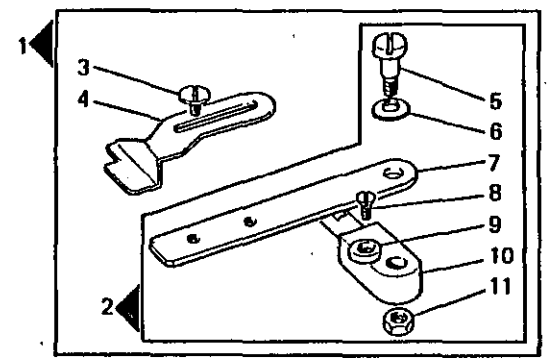
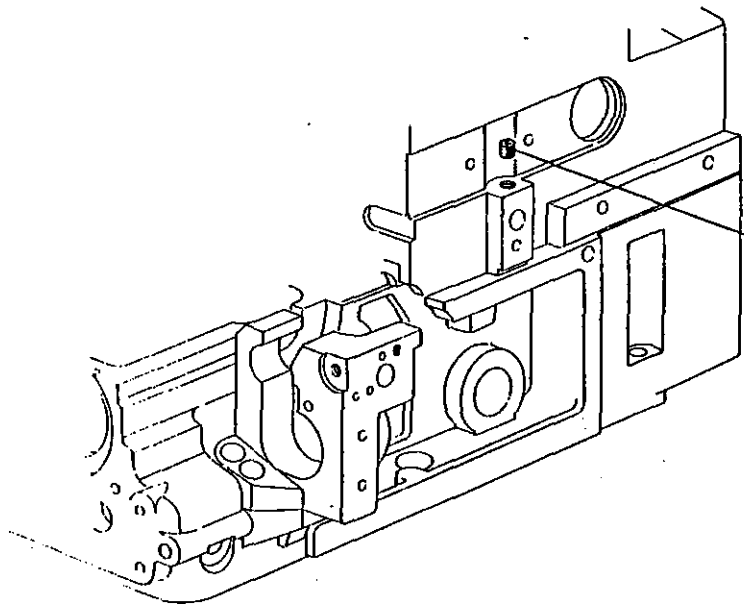

Fig. N.	Part. N. Piece N.	Qt.
1	204919-4-11	1
2	204960-4-00	1
3	201236-0-10	2
4	204920-0-20	1
5	743464-2-00	1
6	702406-0-00	1
7	204647-0-00	1
8	744730-2-00	1
9	300710-0-10	1
10	202970-0-20	1
11	746007-2-00	1
12	729013-2-00	1

From the library of: Diamond Needle Corp

1

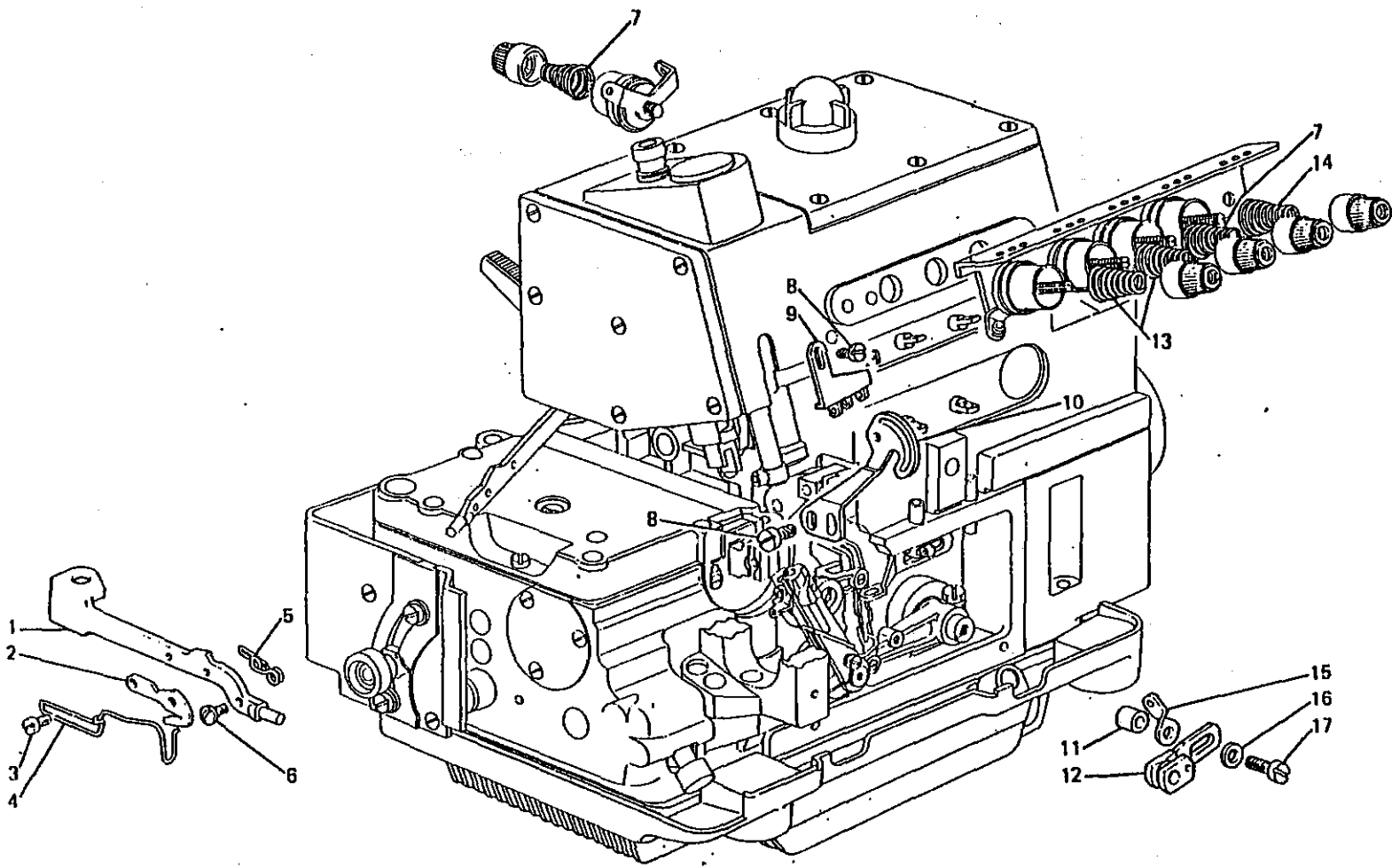
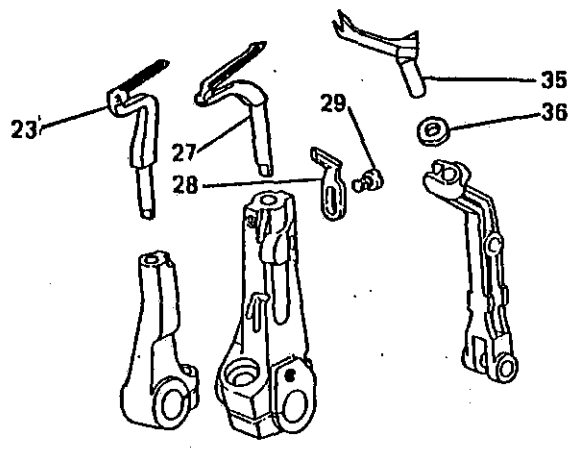
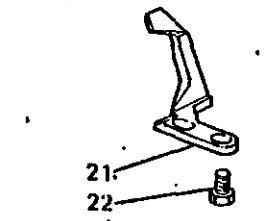
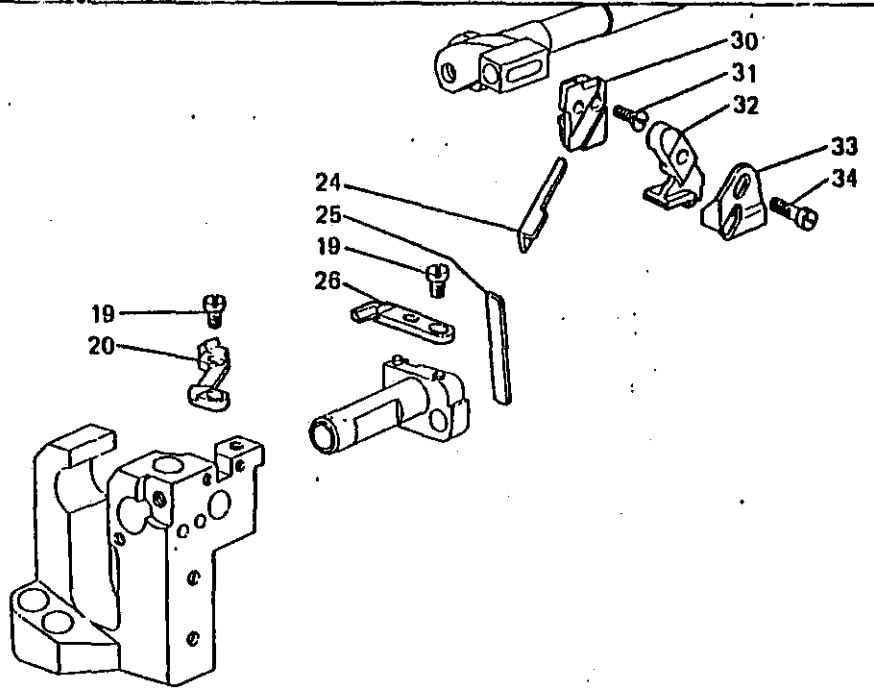
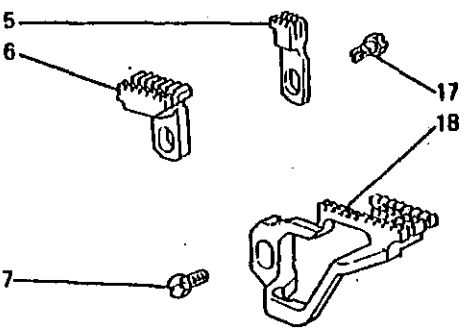
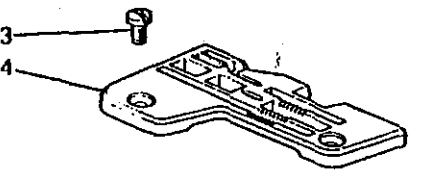
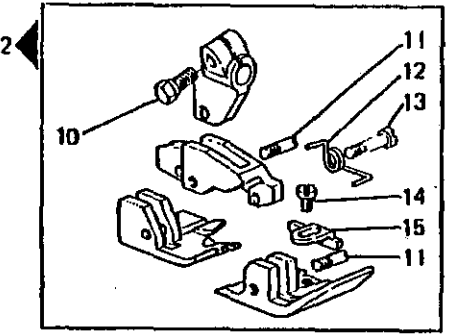
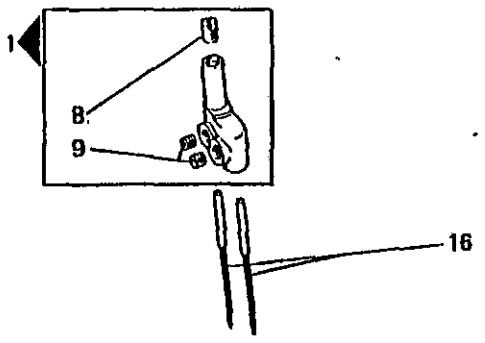

Fig. N.	Part. N. Pièce N.	Qt.
1	209510-0-00	1
2	202194-0-11	1
3	741433-2-00	2
4	991611-0-00	1
5	206985-0-10	1
6	203187-0-10	1
7	202681-0-10	2
8	741558-0-00	3
9	211144-0-00	1
10	211145-0-00	1
11	211742-0-00	1
12	211743-0-00	1
13	202227-0-10	2
14	202228-0-10	1
15	211748-0-00	1
16	704104-2-00	1
17	722440-2-00	1

From the library of Diamond Machine Corp.

SEGUE  
FOLLOWS

2



From the library of: Diamond Needle Corp

Fig N.	Part N. Piece N.	Qt.
1	207526 2-00	1
2	207133-3-06	1
3	744742-2-00	2
4	209058-0-01	1
5	209058-0-00	1
6	2069057-0-00	1
7	202489-0-10	1
8	727021-0-00	1
9	745810-2-00	2
10	204947-0-10	1
11	207554-0-00	2
12	207585-0-00	1
13	207584-0-00	1
14	741413-2-00	1
15	206902-0-01	1
16	765515-1-12	7
17	202488-0 10	1
18	209059-0-00	1
19	741531-2-00	2
20	209945-0-00	1
21	209279-0-00	1
22	740230-2-00	2
23	211310-0-00	1
24	209340-0-00	1
25	209457-0-00	1
26	209194-0-00	1
27	209264-0-10	1
28	209261-0-00	1
29	741538-2-00	1
30	207650-0-01	1
31	744573-0-00	1
32	207653-0-01	1
33	211137-0-00	1
34	207417-0-01	1
35	211247-0-00	1
36	211302-0-00	1

SEGUE  
FOLLOWS

Fig. N.	Part. N. Piece N.	Qt.
1	209268-0-00	1
2	209339-0-00	2
3	209341-0-00	2
4	209342-0-00	1
5	211248-0-00	1

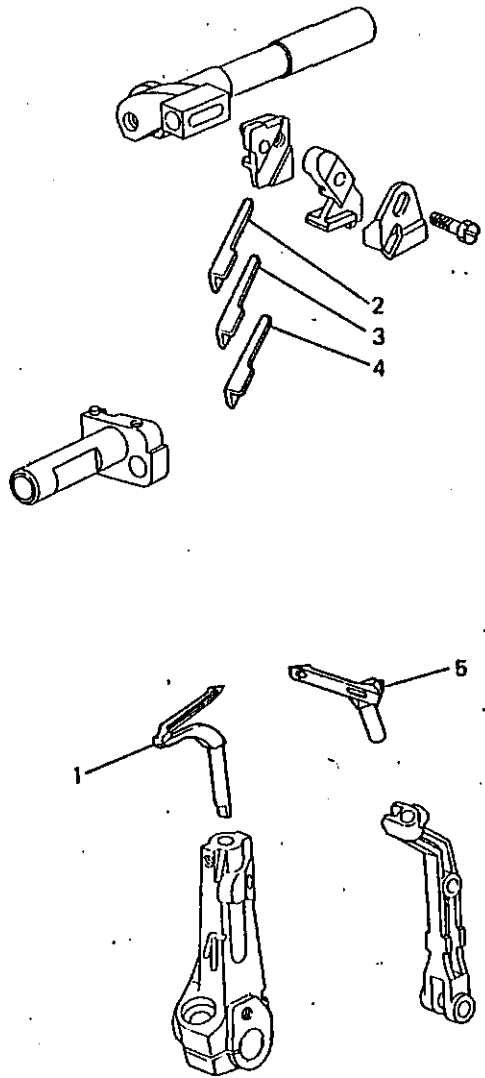

From the library of: Diamond Needle Corp

**CARATTERISTICHE E FUNZIONI DEI PARTICOLARI A RICHIESTA**  
**CHARACTERISTICS AND FUNCTIONS OF REQUESTED SPARE PARTS**  
**CARACTERISTIQUES ET FONCTIONS DES REFERENCES SUR DEMANDE**  
**KENNZEICHEN UND FUNKTIONEN DER TEILE AUF ANFRAGE**  
**CARACTERISTICAS Y FUNCIONES DE LOS REPUESTOS POR SOLICITUD**

010/3

Fig. N.	X	Y	DESCRIZIONE	DESCRIPTION	DESCRIPTION	BENENNUNG	DESCRIPCION
1			Crochet foro ø 0,7.	Looper hole ø 0,7.	Œrochet trou ø 0,7.	Greifer Bohrung ø 0,7.	Garfio orificio ø 0,7.
2		A					
3		AD					
4		WD					
5			Crochet foro ø 0,7.	Looper hole ø 0,7.	Crochet trou ø 0,7.	Greifer Bohrung ø 0,7.	Garfio orificio ø 0,7.

From the library of: Diamond Needle Corp

X	=	LARGHEZZA COSTA	WIDTH OF BIGHT	LARGEUR DE SURJET	UEBERWENDLICHBREITE	ANCHO COSTURA
Y	=	PASSO/FINITURA	DISTANCE/FINISHING	PAS/FINITION	TEILUNG/BEHANDLUNG	PASO/ACABADO
A	=	ACCIAIO	STEEL	ACIER	STAHL	ACERO
D	=	DENTATO	TOOTHED	DENTE	GEZAEHNT	DENTADO
G	=	GOMMATA	RUBBERED	CAOUTCHOUTEE	GUMMIBELEGTEN	ENGOMADO
W	=	WIDIA	WIDIA	WIDIA	WIDIA	WIDIA
* ▲ ■ ●	=	ABBINAMENTI OBBLIGATORI	FIXED COUPLINGS	JUMELAGES OBLIGES	PFLICHT KOPPELUNGEN	COMBINACIONES OBLIGATORIAS

1

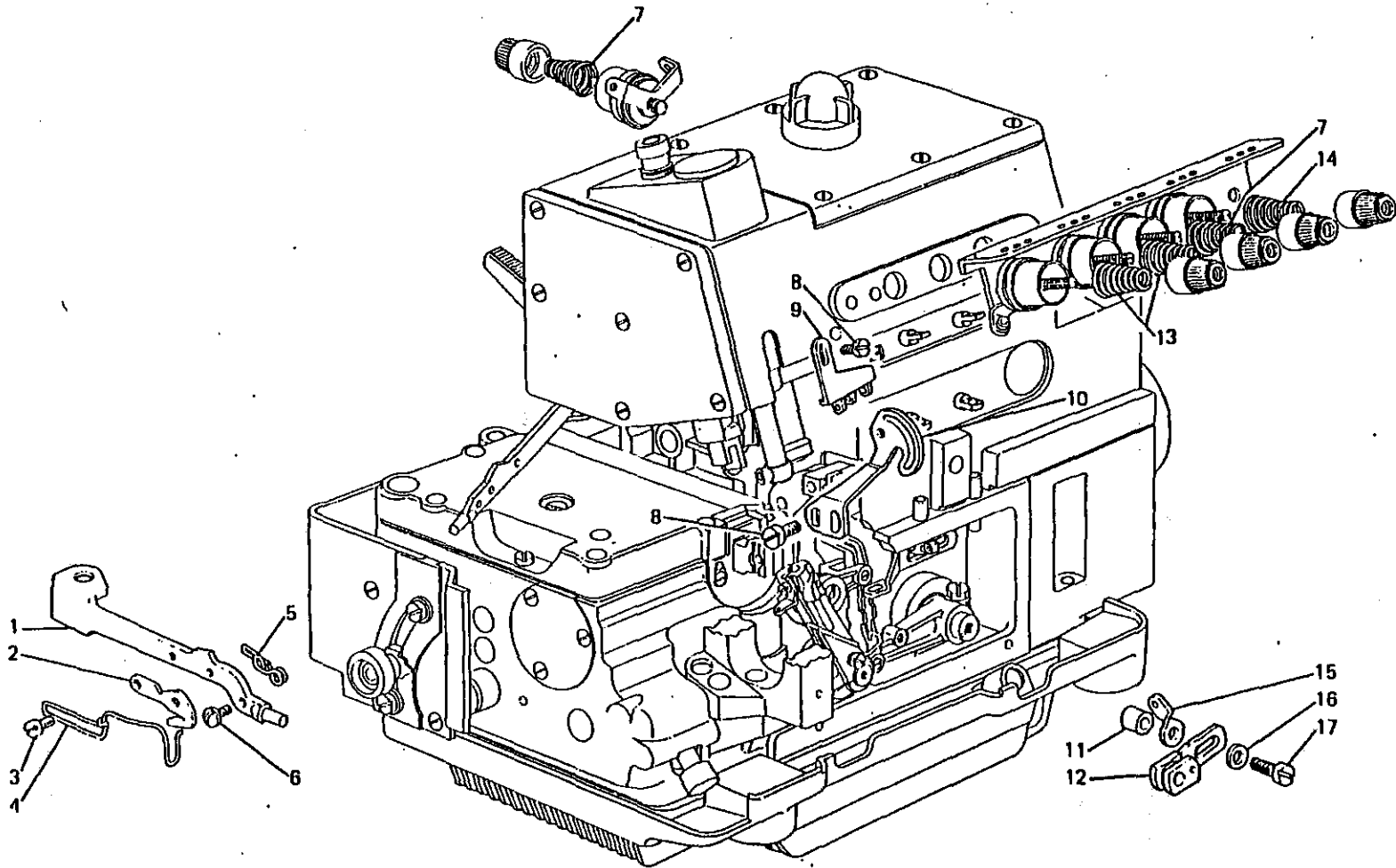
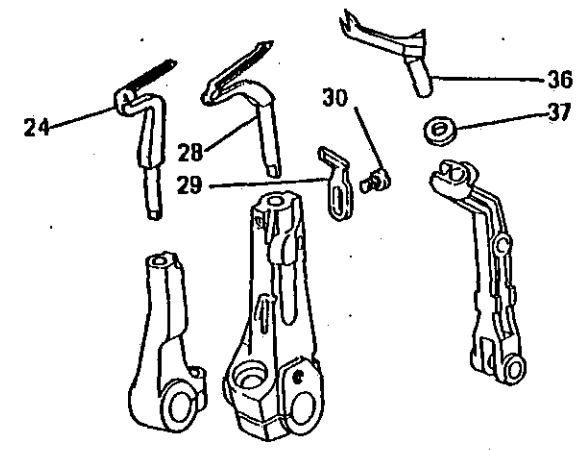
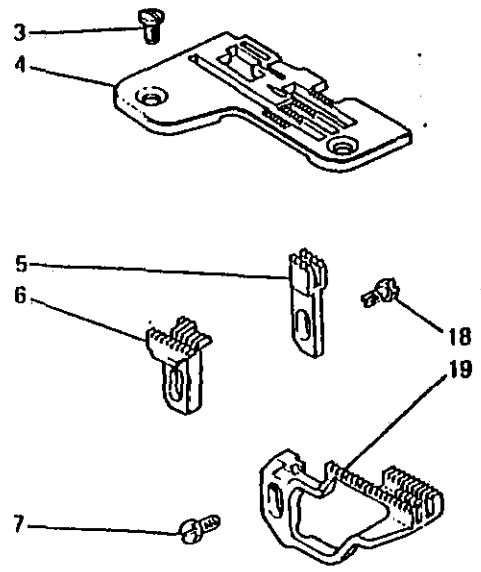
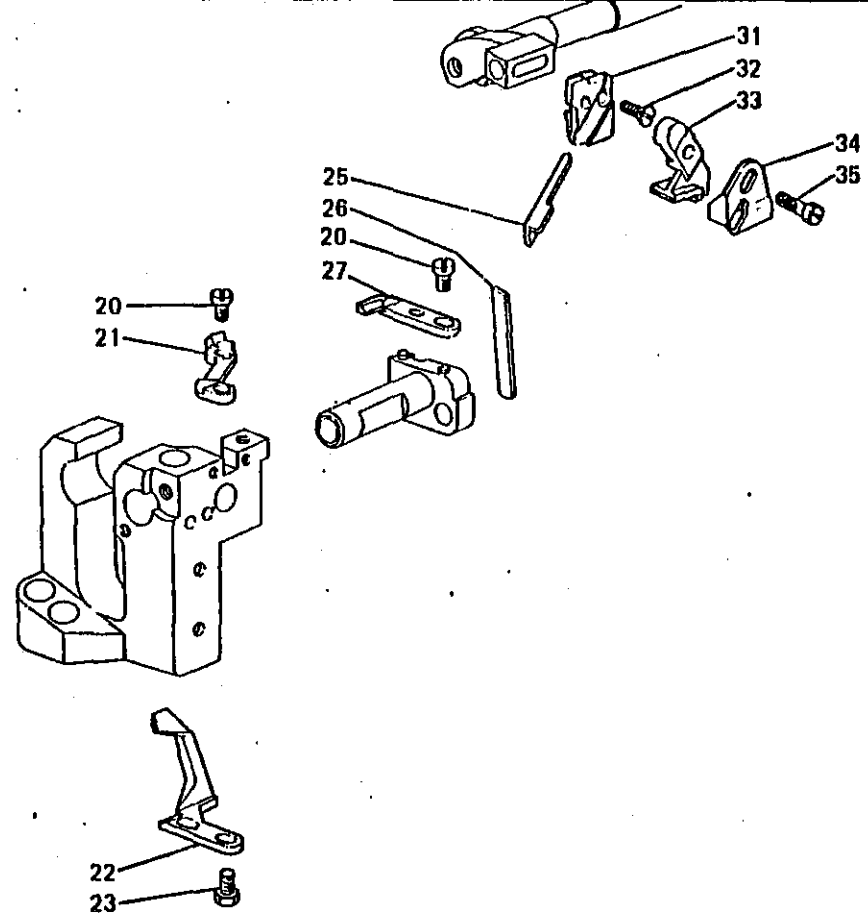
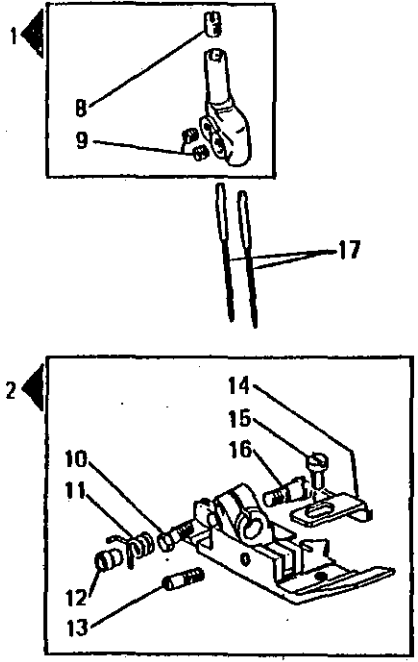

Fig. N.	Part N. Piece N.	Qt.
1	209511-0-00	1
2	202194-0-11	1
3	741433-2-00	2
4	991612-0-00	1
5	205042-0-20	1
6	203187-0-10	1
7	202681-0-10	2
8	741558-0-00	3
9	211144-0-00	1
10	211145-0-00	1
11	211742-0-00	1
12	211743-0-00	1
13	202227-0-10	2
14	202228-0-10	1
15	211748-0-00	1
16	704104-2-00	1
17	722440-2-00	1

From the library of: Diamond Needle Corp

SEGUE  
FOLLOWS



From the library of: Diamond Needle Corp

Fig. N.	Part. N. Piece N.	Qt.
1	207526-2-00	1
2	205070-3-12	1
3	744742-2-00	2
4	205025-0-12	1
5	202609-0-10	1
6	205011-0-10	1
7	202489-0-10	1
8	727021-0-00	1
9	745810-2-00	2
10	204947-0-10	1
11	204894-0-11	1
12	204895-0-11	1
13	204869-0-11	1
14	204878-0-11	1
15	741413-2-00	1
16	204889-0-10	1
17	765510-1-10	7
18	202488-0-10	1
19	205007-0-13	1
20	741531-2-00	2
21	209945-0-00	1
22	209279-0-00	1
23	740230-2-00	2
24	211310-0-00	1
25	209351-0-00	1
26	207020-2-01	2
27	209194-0-00	1
28	209264-0-10	1
29	209261-0-00	1
30	741538-2-00	1
31	207650-0-01	1
32	744573-0-00	1
33	207653-0-01	1
34	211137-0-00	1
35	207417-0-01	1
36	211247-0-00	1
37	211302-0-00	1

SEGUE  
FOLLOWS



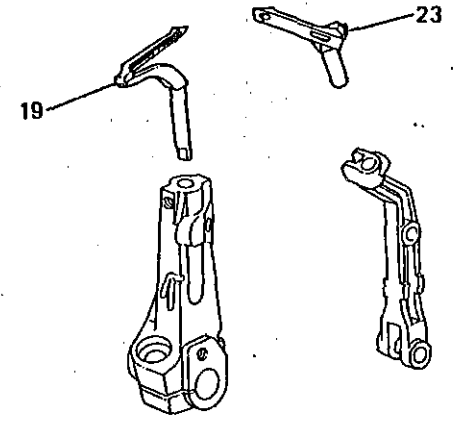
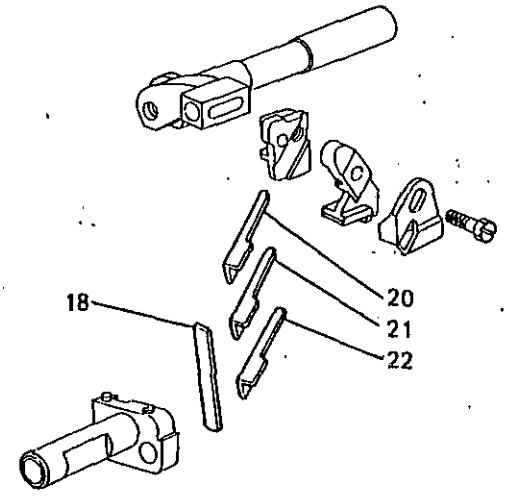
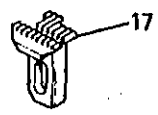
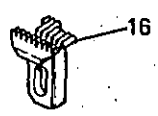
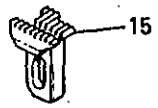
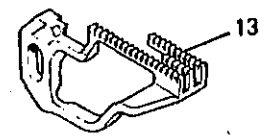
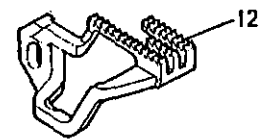
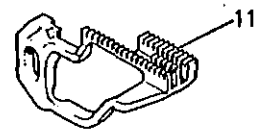
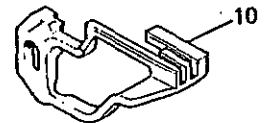
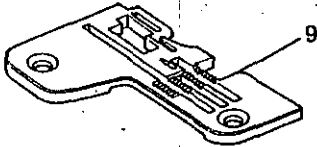
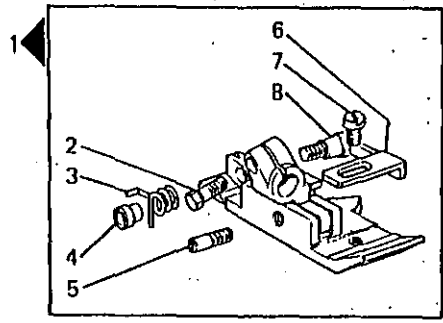

Fig. N.	Part. N. Piece N.	Qt.
1	207055-3-01	1
2	204947-0-10	1
3	204894-0-11	1
4	204895-0-11	1
5	204869-0-11	1
6	207053-0-01	1
7	741413-2-00	1
8	204889-0-10	1
9	207051-0-02	1
10	205009-2-12	1
11	205059-0-13	1
12	205060-0-13	1
13	207052-0-02	1
14	205013-2-11	1
15	205064-0-10	1
16	205065-0-10	1
17	205011-0-10	1
18	204693-0-11	1
19	209268-0-00	1
20	209352-0-00	2
21	209353-0-00	1
22	209354-0-00	2
23	211248-0-00	1

From the library of: Diamond Needle Corp

**CARATTERISTICHE E FUNZIONI DEI PARTICOLARI A RICHIESTA**  
**CHARACTERISTICS AND FUNCTIONS OF REQUESTED SPARE PARTS**  
**CARACTERISTIQUES ET FONCTIONS DES REFERENCES SUR DEMANDE**  
**KENNZEICHEN UND FUNKTIONEN DER TEILE AUF ANFRAGE**  
**CARACTERISTICAS Y FUNCIONES DE LOS REPUESTOS POR SOLICITUD**

011/3

Fig. N.	X	Y	DESCRIZIONE	DESCRIPTION	DESCRIPTION	BENENNUNG	DESCRIPCION
1			Per costa soprappiglio da 2 mm.	For bight 2 mm.	Pour surjet de 2 mm.	Für Überwendlichkante von 2 mm.	Para ancho costura puntada de seguridad 2 mm.
9*	2						
10■		G					
11●		2					
12▲		2					
13*		1,5					
14■		G					
15●		2					
16▲		2					
17*		2	In dotazione.	Normal setting.	En dotation	Als Ausstattung.	En dotación.
18		A					
19			Crochet foro ø 0,7.	Looper hole ø 0,7.	Crochet trou ø 0,7.	Greifer Bohrung ø 0,7.	Garfio orificio ø 0,7.
20		A					
21		WD					
22		AD					
23			Crochet foro ø 0,7.	Looper hole ø 0,7.	Crochet trou ø 0,7.	Greifer Bohrung ø 0,7.	Garfio orificio ø 0,7.

From the library of: Diamond Needle Corp

X	-	LARGHEZZA COSTA	WIDTH OF BIGHT	LARGEUR DE SURJET	UEBERWENDLICHBREITE	ANCHO COSTURA
Y	-	PASSO/FINITURA	DISTANCE/FINISHING	PAS/FINITION	TEILUNG/BEHANDLUNG	PASO/ACABADO
A	-	ACCIAIO	STEEL	ACIER	STAHL	ACERO
D	-	DENTATO	TOOTHED	DENTE	GEZAEHNT	DENTADO
G	-	GOMMATA	RUBBERED	CAOUTCHOUTEE	GUMMIBELEGTEN	ENGOMADO
W	-	WIDIA	WIDIA	WIDIA	WIDIA	WIDIA
* ▲ ■ ●	-	ABBINAMENTI OBBLIGATORI	FIXED COUPLINGS	JUMELAGES OBLIGES	PFLICHT KOPPELUNGEN	COMBINACIONES OBLIGATORIAS

1

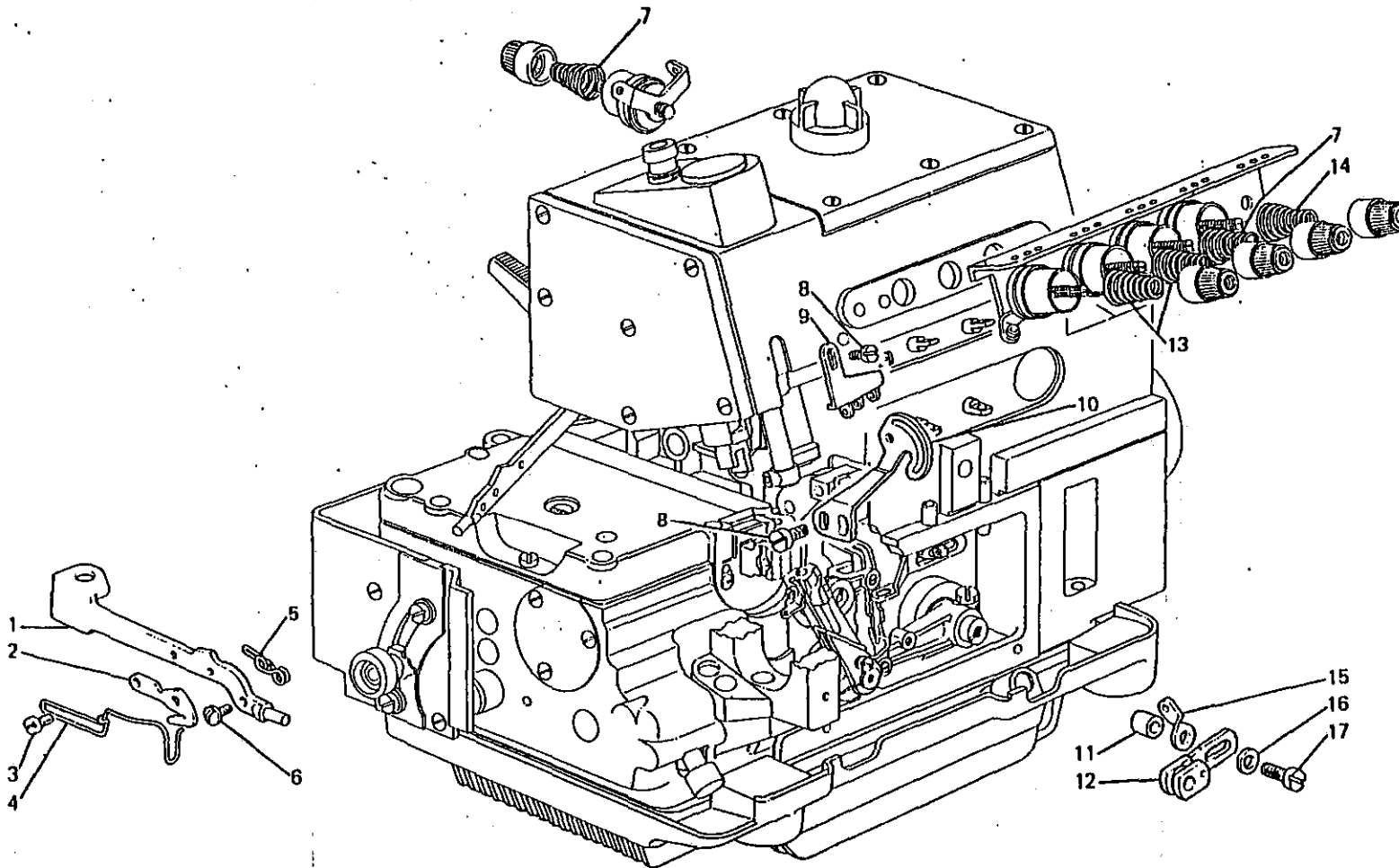
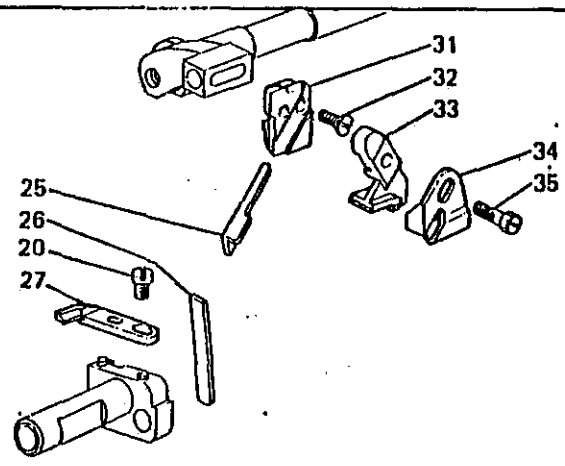
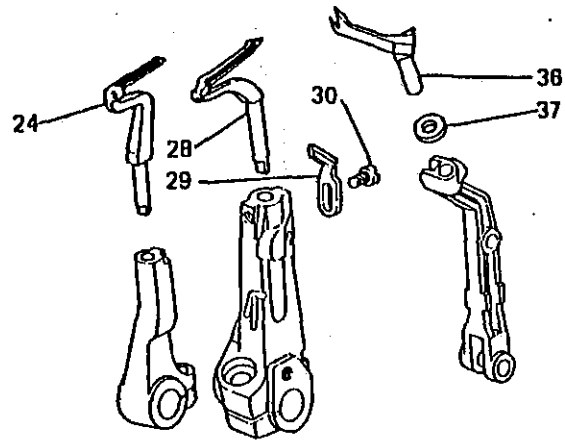
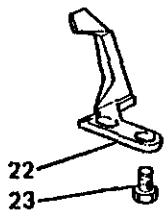
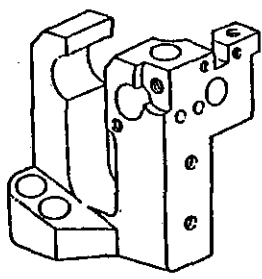
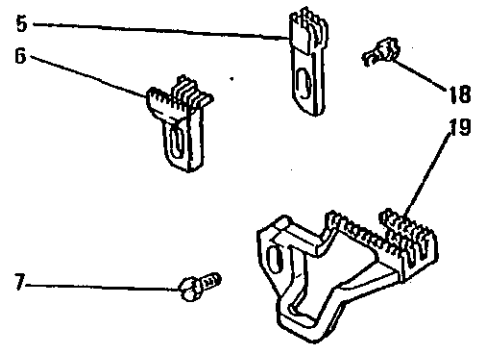
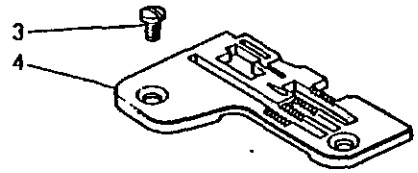
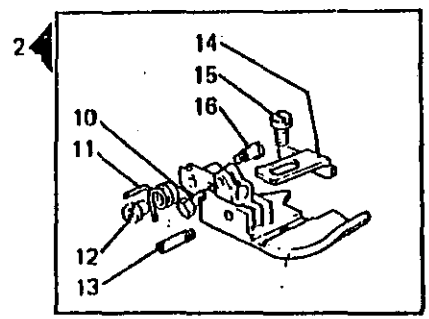
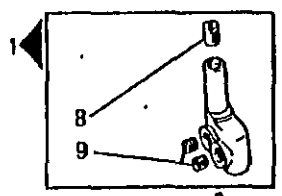

Fig. N.	Part. N. Piece N.	Qt.
1	209511-0-00	1
2	202194-0-11	1
3	741433-2-00	2
4	991812-0-00	1
5	205042-0-20	1
6	203187-0-10	1
7	202691-0-10	2
8	741558-0-00	3
9	211144-0-00	1
10	211145-0-00	1
11	211742-0-00	1
12	211743-0-00	1
13	202227-0-10	2
14	202228-0-10	1
15	211748-0-00	1
16	704104-2-00	1
17	722440-2-00	1

From the library of: Diamond Needle Corp

SEQUE  
FOLLOWS



Copyright © 1994 by Diamond Needle Corp.

Fig. N.	Part N. P'cece N.	Qt.
1	207526-2-00	1
2	205110-3-12	1
3	744742-2-00	2
4	205025-0-12	1
5	202609-0-10	1
6	205065-0-10	1
7	202489-0-10	1
8	727021-0-00	1
9	745810-2-00	2
10	204947-0-10	1
11	204894-0-11	1
12	204895-0-11	1
13	204869-0-11	1
14	204878-0-11	1
15	741413-2-00	1
16	204889-0-10	1
17	765510-1-11	7
18	202488-0-10	1
19	205060-0-13	1
20	741531-2-00	2
21	209945-0-00	1
22	209279-0-00	1
23	740230-2-00	2
24	211310-0-00	1
25	209351-0-00	1
26	207020-2-01	1
27	209194-0-00	1
28	209264-0-10	1
29	209261-0-00	1
30	741538-2-00	1
31	207650-0-01	1
32	744573-0-00	1
33	207653-0-01	1
34	211137-0-00	1
35	207417-0-01	1
36	211247-0-00	1
37	211302-0-00	1

SEGUE  
FOLLOWS

**CARATTERISTICHE E FUNZIONI DEI PARTICOLARI A RICHIESTA**  
**CHARACTERISTICS AND FUNCTIONS OF REQUESTED SPARE PARTS**  
**CARACTERISTIQUES ET FONCTIONS DES REFERENCES SUR DEMANDE**  
**KENNZEICHEN UND FUNKTIONEN DER TEILE AUF ANFRAGE**  
**CARACTERISTICAS Y FUNCIONES DE LOS REPUESTOS POR SOLICITUD**

Fig. N.	X	Y	DESCRIZIONE	DESCRIPTION	DESCRIPTION	BENENNUNG	DESCRIPCION
1		1,5					
2●		G					
3▲		2					
4		1,5					
5●		G					
6▲		2					
7		A					
8		A	Crochet foro ø 0,7.	Looper hole ø 0,7.	Crochet trou ø 0,7.	Greifer Bohrung ø 0,7.	Garfo orifido ø 0,7.
9		A					
10		WD					
11		AD					
12			Crochet foro ø 0,7.	Looper hole ø 0,7.	Crochet trou ø 0,7.	Greifer Bohrung ø 0,7.	Garfo orifido ø 0,7.

From the library of: Diamond Needle Corp

- |         |   |                         |                    |                   |                     |                            |
|---------|---|-------------------------|--------------------|-------------------|---------------------|----------------------------|
| X       | - | LARGHEZZA COSTA         | WIDTH OF BIGHT     | LARGEUR DE SURJET | UEBERWENDLICHBREITE | ANCHO COSTURA              |
| Y       | - | PASSO/FINITURA          | DISTANCE/FINISHING | PAS/FINITION      | TEILUNG/BEHANDLUNG  | PASO/ACABADO               |
| A       | - | ACCIAIO                 | STEEL              | ACIER             | STAHL               | ACERO                      |
| D       | - | DENTATO                 | TOOTHED            | DENTE             | GEZAEHNT            | DENTADO                    |
| G       | - | GOMMATA                 | RUBBERED           | CAOUTCHOUTEE      | GUMMIBELEGTEN       | ENGOMADO                   |
| W       | - | WIDIA                   | WIDIA              | WIDIA             | WIDIA               | WIDIA                      |
| * ▲ ■ ● | - | ABBINAMENTI OBBLIGATORI | FIXED COUPLINGS    | JUMELAGES OBLIGES | PFLICHT KOPPELUNGEN | COMBINACIONES OBLIGATORIAS |

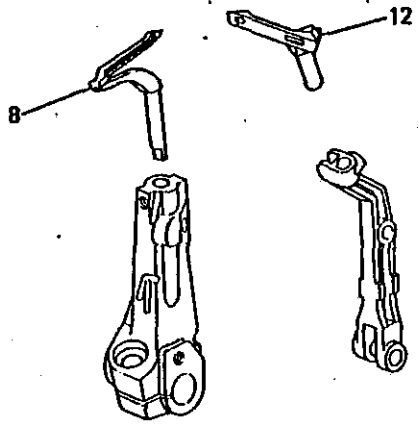
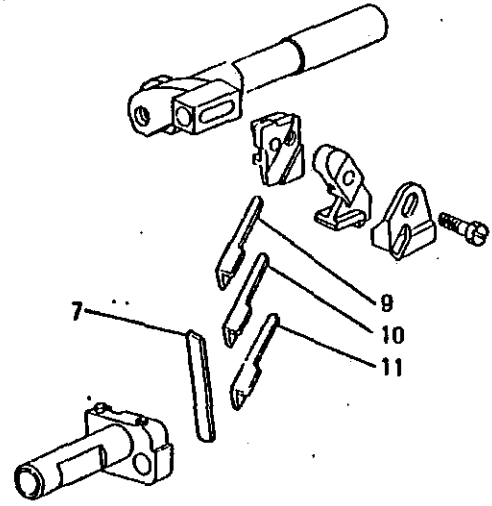
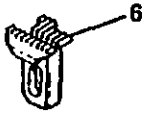
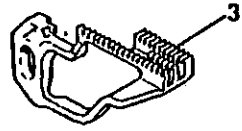
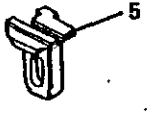
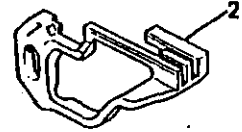
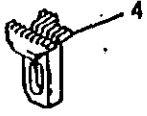
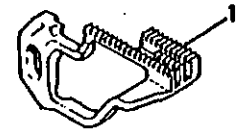

From the library of Diamond Nesque Corp

Fig. N.	Part N. Piece N.	Qt.
1	205007-0-13	1
2	205009-2-12	1
3	205059-0-13	1
4	205011-0-10	1
5	205013-2-11	1
6	205064-0-10	1
7	204693-0-11	2
8	209268-0-00	1
9	209352-0-00	2
10	209353-0-00	1
11	209354-0-00	2
12	211248-0-00	1

SEQUE  
FOLLOWS

Fig. N.	Part. N. Piece N.	Qt.
1	204919-4-11	1
2	204960-4-00	1
3	201236-0-10	2
4	204920-0-20	1
5	743464-2-00	1
6	702406-0-00	1
7	204647-0-00	1
8	744730-2-00	1
9	300710-0-10	1
10	202970-0-20	1
11	746007-2-00	1
12	729013-2-00	1

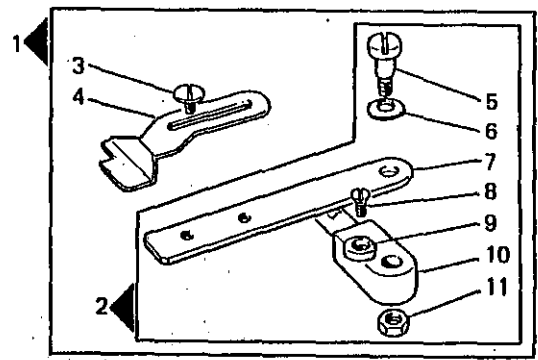
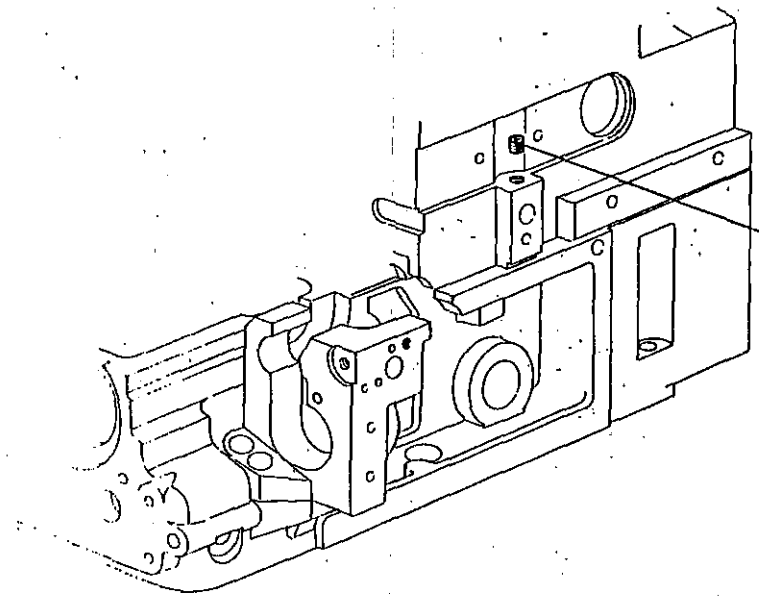

From the library of: Diamond Needle Corp

**CARATTERISTICHE E FUNZIONI DEI PARTICOLARI A RICHIESTA**  
**CHARACTERISTICS AND FUNCTIONS OF REQUESTED SPARE PARTS**  
**CARACTERISTIQUES ET FONCTIONS DES REFERENCES SUR DEMANDE**  
**KENNZEICHEN UND FUNKTIONEN DER TEILE AUF ANFRAGE**  
**CARACTERISTICAS Y FUNCIONES DE LOS REPUESTOS POR SOLICITUD**

012/4

Fig. N.	X	Y	DESCRIZIONE	DESCRIPTION	DESCRIPTION	BENENNUNG	DESCRIPCION
1			Guida ribaltabile per limitare l'altezza del taglio	Folder for limiting cutting thickness.	Guide escamotable pour limiter la hauteur de coupe.	Klappführung um die Schneidhöhe zu begrenzen.	Guía volcable para limitar la altura del corte.

From the library of: Diamond Needle Corp

X	=	LARGHEZZA COSTA	WIDTH OF BIGHT	LARGEUR DE SURJET	UEBERWENDLICHBREITE	ANCHO COSTURA
Y	=	PASSO/FINITURA	DISTANCE/FINISHING	PAS/FINITION	TEILUNG/BEHANDLUNG	PASO/ACABADO
A	=	ACCIAIO	STEEL	ACIER	STAHL	ACERO
D	=	DENTATO	TOOTHED	DENTE	GEZAEHNT	DENTADO
G	=	GOMMATA	RUBBERED	CAOUTCHOUTEE	GUMMIBELGTE	ENGOMADO
W	=	WIDIA	WIDIA	WIDIA	WIDIA	WIDIA
* ▲ ■ ●	=	ABBINAMENTI OBBLIGATORI	FIXED COUPLINGS	JUMELAGES OBLIGES	PFLICHT KOPPELUNGEN	COMBINACIONES OBLIGATORIAS



1

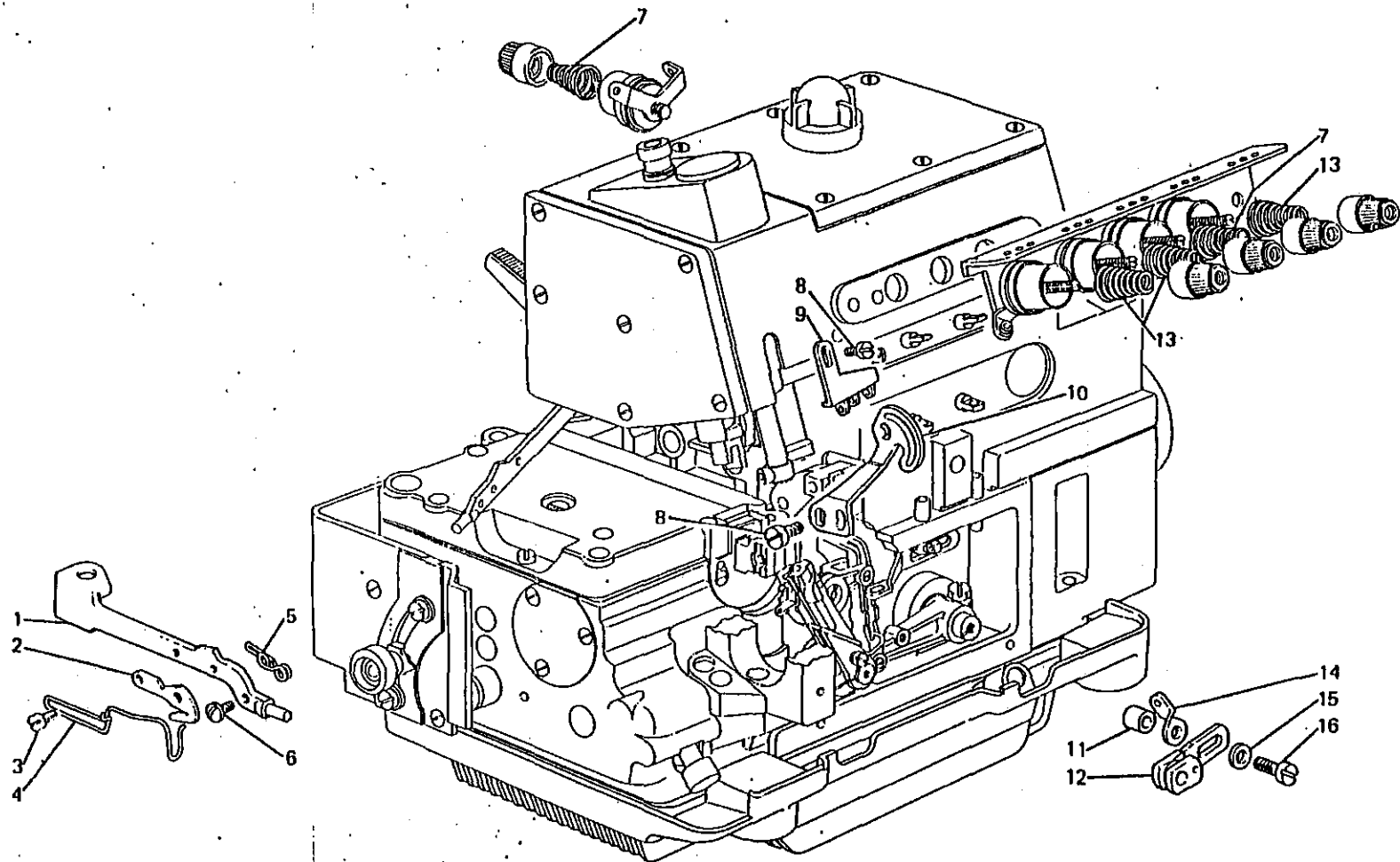
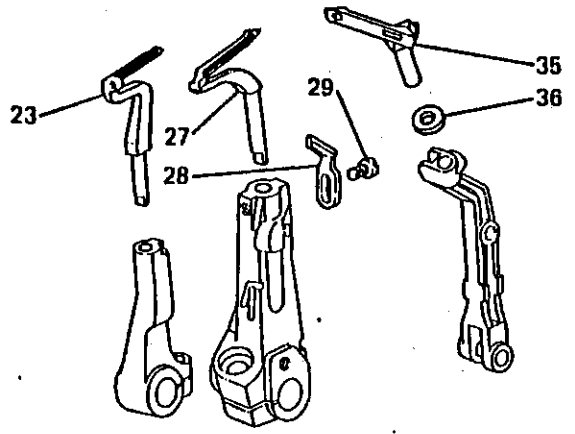
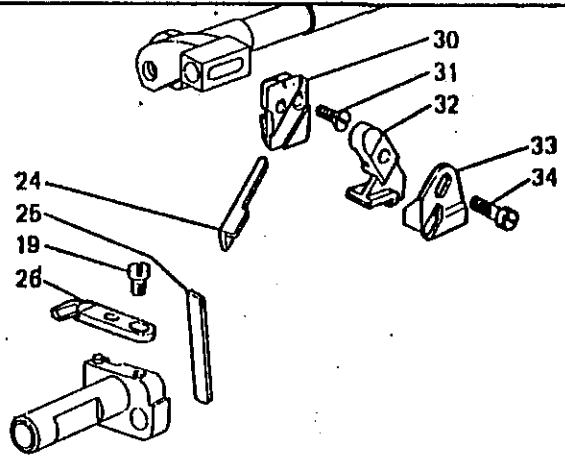
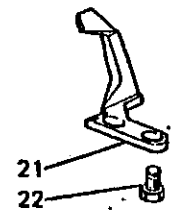
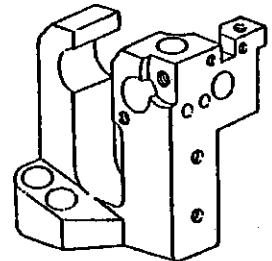
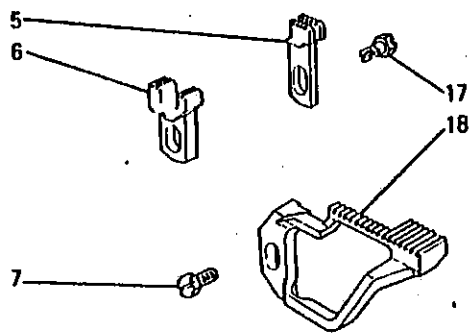
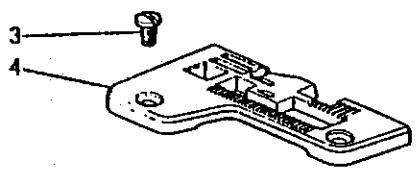
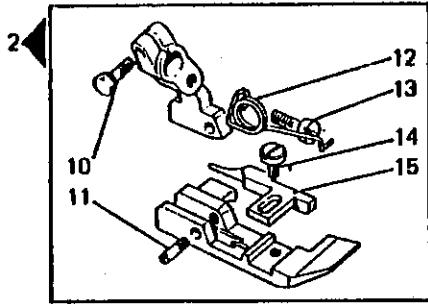
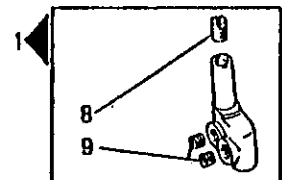

Fig. N.	Part. N. Pleca N.	Qt.
1	209512-0-00	1
2	202194-0-11	1
3	741433-2-00	2
4	991612-0-00	1
5	205042-0-20	1
6	203187-0-10	1
7	202681-0-10	2
8	741558-0-00	3
9	211144-0-00	1
10	211148-0-00	1
11	211742-0-00	1
12	211743-0-00	1
13	202227-0-10	3
14	211748-0-00	1
15	704104-2-00	1
16	722440-2-00	1

From the library of: Diamond Needle Corp

SEGUE  
FOLLOWS



From the library of: Diamond Needle Corp

Fig. N.	Part. N. Piece N.	Qt.
1	207526-2-00	1
2	205829-3-00	1
3	744742-2-00	2
4	208574-0-01	1
5	208576-0-00	1
6	208575-0-00	1
7	202489-0-10	1
8	727021-0-00	1
9	745810-2-00	2
10	204947-0-10	1
11	207749-0-00	1
12	205822-2-00	1
13	741654-2-00	1
14	721411-2-00	1
15	205835-0-00	1
16	765510-1-80	7
17	202488-0-10	1
18	205825-0-01	1
19	741531-2-00	2
20	209945-0-00	1
21	209279-0-00	1
22	740230-2-00	2
23	211310-0-00	1
24	209355-0-00	1
25	207020-2-01	2
26	209194-0-00	1
27	209264-0-10	1
28	209261-0-00	1
29	741538-2-00	1
30	207650-0-01	1
31	744573-0-00	1
32	207653-0-01	1
33	211137-0-00	1
34	207417-0-01	1
35	211248-0-00	1
36	211301-0-00	1

SEQUE  
FOLLOWS

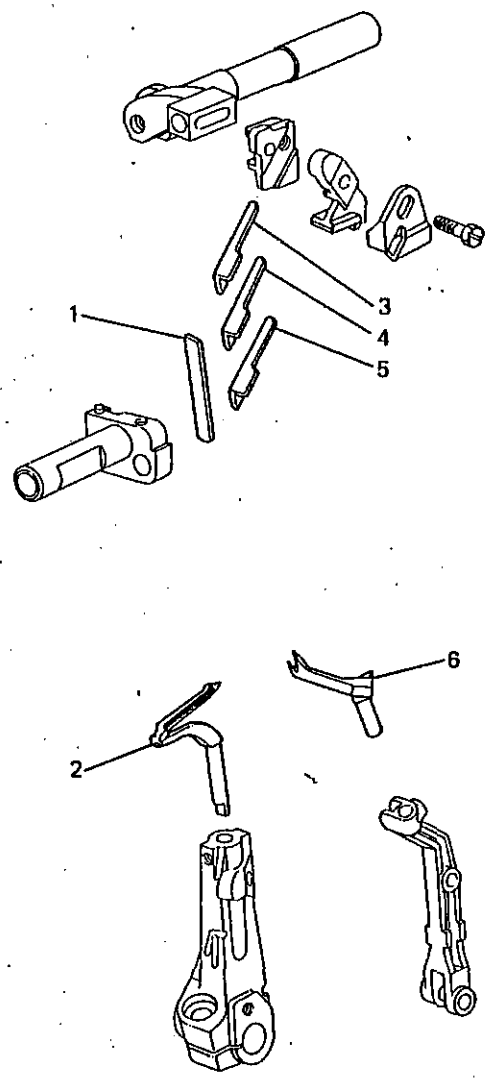

From the library of: Diamond Needle Corp

Fig. N.	Part. N. Piece N.	Qt.
1	204693-0-11	1
2	209268-0-00	1
3	209356-0-00	2
4	209357-0-00	1
5	209358-0-00	2
6	211247-0-00	1

**CARATTERISTICHE E FUNZIONI DEI PARTICOLARI A RICHIESTA**  
**CHARACTERISTICS AND FUNCTIONS OF REQUESTED SPARE PARTS**  
**CARACTERISTIQUES ET FONCTIONS DES REFERENCES SUR DEMANDE**  
**KENNZEICHEN UND FUNKTIONEN DER TEILE AUF ANFRAGE**  
**CARACTERISTICAS Y FUNCIONES DE LOS REPUESTOS POR SOLICITUD**

015/3

Fig. N.	X	Y	DESCRIZIONE	DESCRIPTION	DESCRIPTION	BENENNUNG	DESCRIPCION
1		A	Crochet loto ø 0,7.	Looper hole ø 0,7.	Crochet trou ø 0,7.	Greifer Bohrung ø 0,7.	Garfo orificio ø 0,7.
2		A					
3		A					
4		WD					
5		AD					
6			Crochet cieco.	Blind looper.	Crochet aveugle.	Blindgreifer.	Garfo ciego.

From the library of: Diamond Needle Corp

X	=	LARGHEZZA COSTA	WIDTH OF BIGHT	LARGEUR DE SURJET	UEBERWENDLICHBREITE	ANCHO COSTURA
Y	=	PASSO/FINITURA	DISTANCE/FINISHING	PAS/FINITION	TEILUNG/BEHANDLUNG	PASO/ACABADO
A	=	ACCIAIO	STEEL	ACIER	STAHL	ACERO
D	=	DENTATO	TOOTHED	DENTE	GEZAEHNT	DENTADO
G	=	GOMMATA	RUBBERED	CAOUTCHOUTEE	GUMMIBELEGTEN	ENGOMADO
W	=	WIDIA	WIDIA	WIDIA	WIDIA	WIDIA
★ ▲ ■ ●	=	ABBINAMENTI OBBLIGATORI	FIXED COUPLINGS	JUMELAGES OBLIGES	PFLICHT KOPPELUNGEN	COMBINACIONES OBLIGATORIAS

1

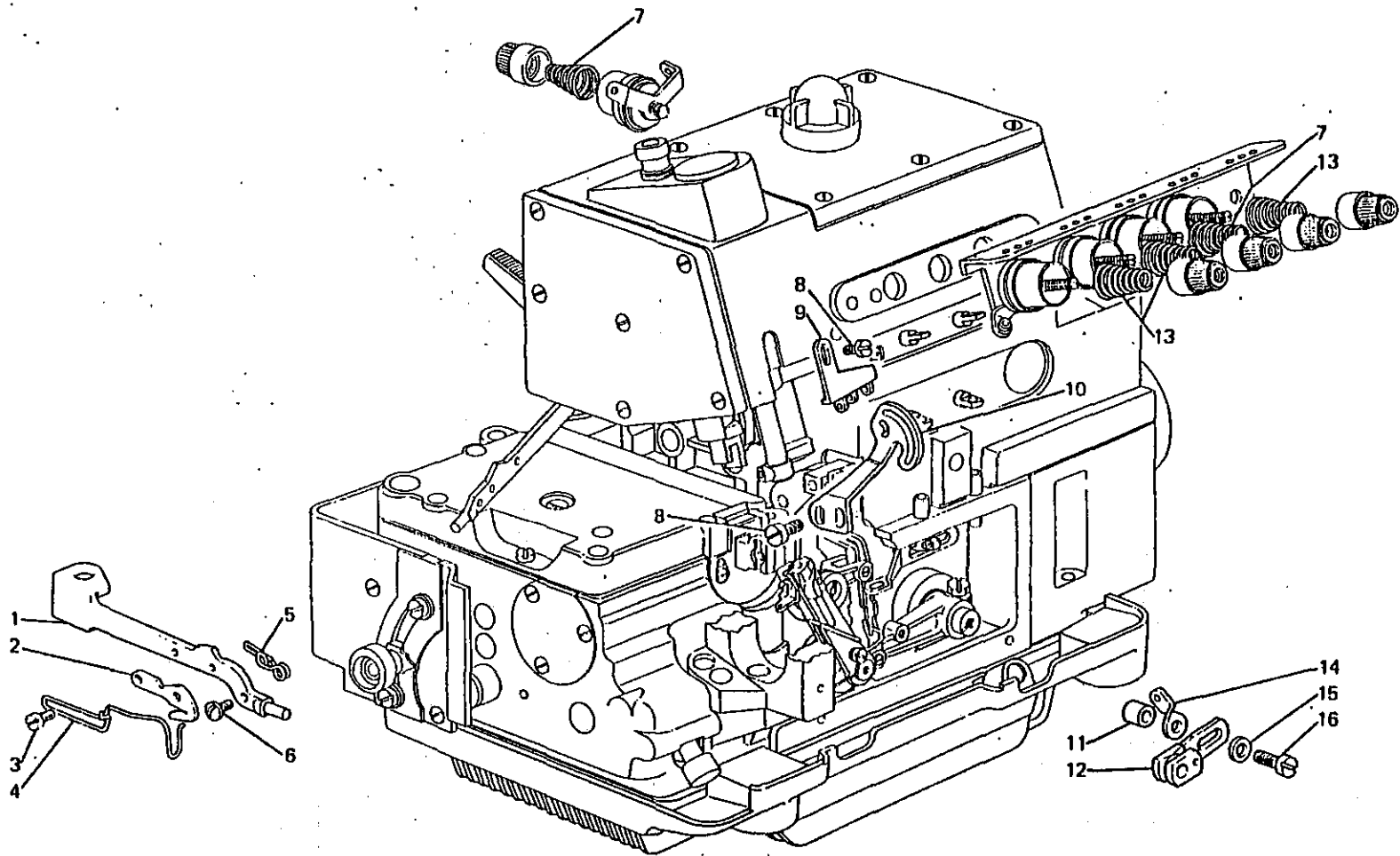
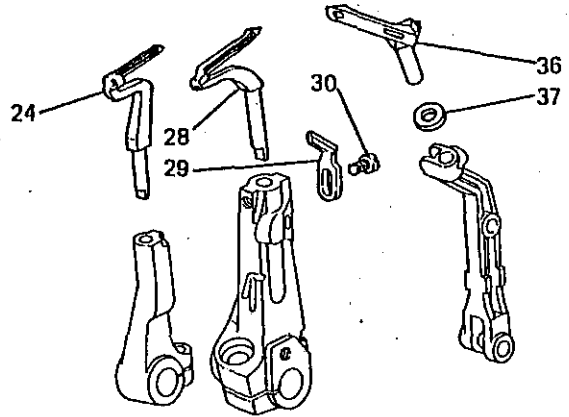
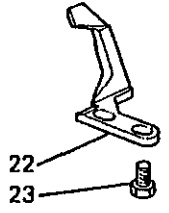
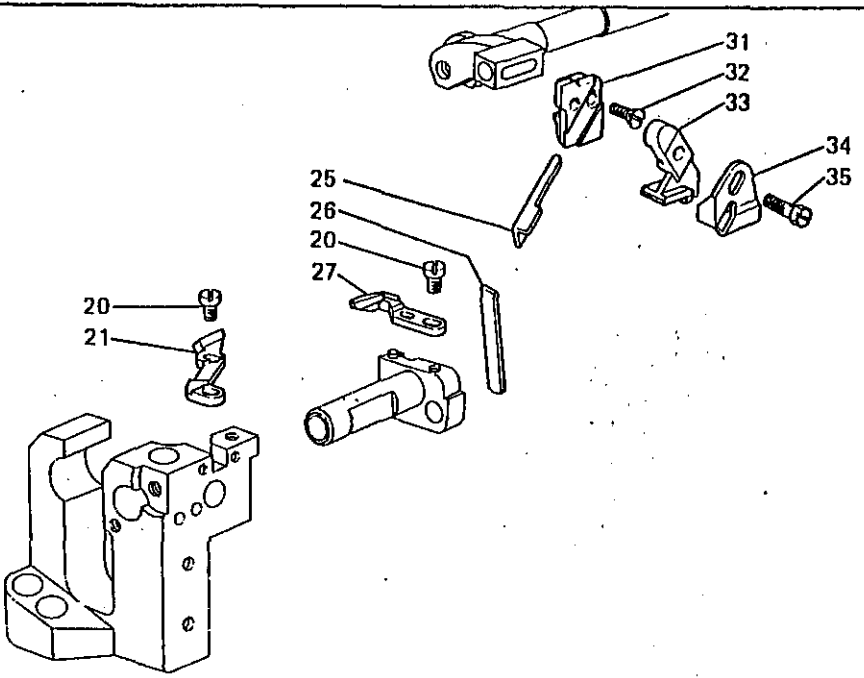
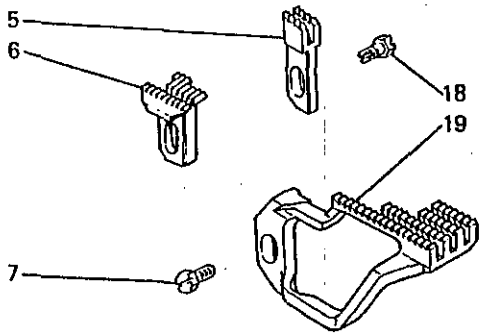
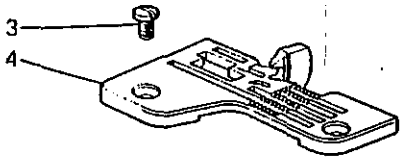
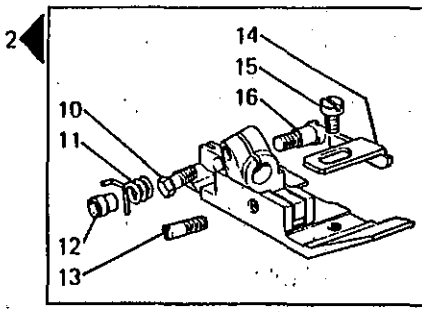
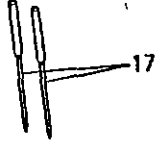
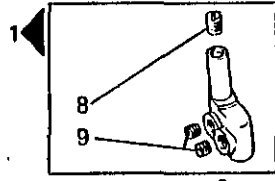

Fig. N.	Part. N. Piece N.	Qt.
1	209511-0-00	1
2	202194-0-11	1
3	741433-2-00	2
4	891612-0-00	1
5	204891-0-20	1
6	203187-0-10	1
7	202681-0-10	2
8	741558-0-00	3
9	211143-0-00	1
10	211146-0-00	1
11	211742-0-00	1
12	211743-0-00	1
13	202227-0-10	3
14	211748-0-00	1
15	704104-2-00	1
16	722440-2-00	1

From the library of: Diamond Needle Corp

SEQUE  
FOLLOWS



From the library of: Diamond Needle Corp

SEQUE  
FOLLOWS

Fig. N.	Part N. Piece N.	Qt.
1	207524-2-00	1
2	204873-3-12	1
3	744742-2-00	2
4	206172-2-01	1
5	202609-0-10	1
6	204850-0-10	1
7	202489-0-10	1
8	727021-0-00	1
9	745810-2-00	2
10	204947-0-10	1
11	204894-0-11	1
12	204895-0-11	1
13	204869-0-11	1
14	204879-0-11	1
15	741413-2-00	1
16	204889-0-10	1
17	765510-1-90	7
18	202488-0-10	1
19	207176-0-03	1
20	741531-2-00	2
21	209192-0-00	1
22	209279-0-00	1
23	740230-2-00	2
24	211310-0-00	1
25	209356-0-00	1
26	204693-0-11	1
27	209195-0-00	1
28	209264-0-10	1
29	209261-0-00	1
30	741538-2-00	1
31	207649-0-01	1
32	744573-0-00	1
33	207653-0-01	1
34	211137-0-00	1
35	207417-0-01	1
36	211248-0-00	1
37	211301-0-00	1

3

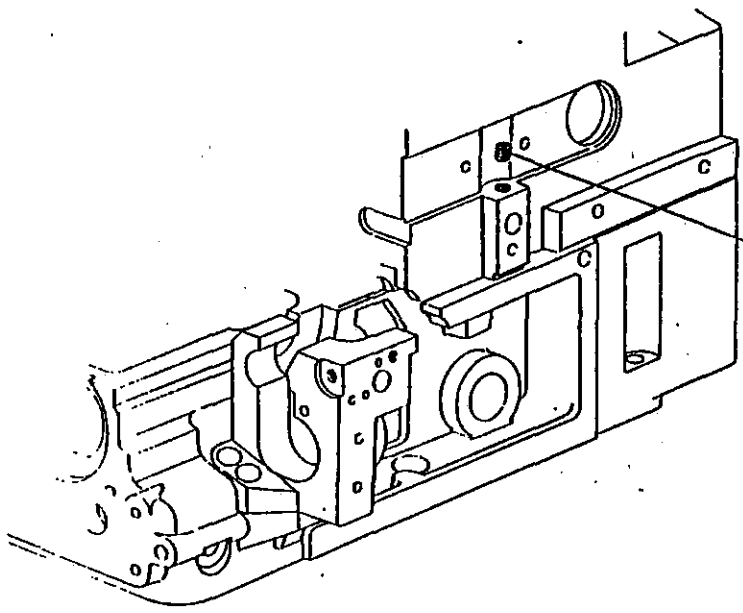

5

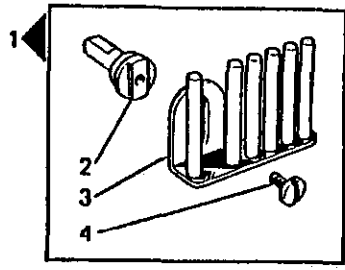

Fig. N.	Part N. Piece N.	Qt.
1	990496-4-10	1
2	990497-0-10	1
3	990495-2-10	1
4	201236-0-10	1
6	729013-2-00	1

From the library of: Diamond Needle Corp

SEGUE  
FOLLOWS

**CARATTERISTICHE E FUNZIONI DEI PARTICOLARI A RICHIESTA**  
**CHARACTERISTICS AND FUNCTIONS OF REQUESTED SPARE PARTS**  
**CARACTERISTIQUES ET FONCTIONS DES REFERENCES SUR DEMANDE**  
**KENNZEICHEN UND FUNKTIONEN DER TEILE AUF ANFRAGE**  
**CARACTERISTICAS Y FUNCIONES DE LOS REPUESTOS POR SOLICITUD**

018/4

Fig. N.	X	Y	DESCRIZIONE	DESCRIPTION	DESCRIPTION	BENENNUNG	DESCRIPCION
1		W	Crochet loto ø 0,7.	Looper hole ø 0,7.	* Crochet trou ø 0,7.	Greifer Bohrung ø 0,7.	Garfio orificio ø 0,7.
2		W					
3		W					
4		WD					
5		AD					
6			Crochet cieco.	Blind looper.	Crochet aveugle.	Blindgreifer.	Garfio ciego.

From the library of: Diamond Needle Corp

X	-	LARGHEZZA COSTA	WIDTH OF BIGHT	LARGEUR DE SURJET	UEBERWENDLICHBREITE	ANCHO COSTURA
Y	-	PASSO/FINITURA	DISTANCE/FINISHING	PAS/FINITION	TEILUNG/BEHANDLUNG	PASO/ACABADO
A	-	ACCIAIO	STEEL	ACIER	STAHL	ACERO
D	-	DENTATO	TOOTHED	DENTE	GEZAEHNT	DENTADO
G	-	GOMMATA	RUBBERED	CAOUTCHOUTEE	GUMMIBELEGTEN	ENGOMADO
W	-	WIDIA	WIDIA	WIDIA	WIDIA	WIDIA
* ▲ ■ ●	-	ABBINAMENTI OBBLIGATORI	FIXED COUPLINGS	JUMELAGES OBLIGES	PFLICHT KOPPELUNGEN	COMBINACIONES OBLIGATORIAS



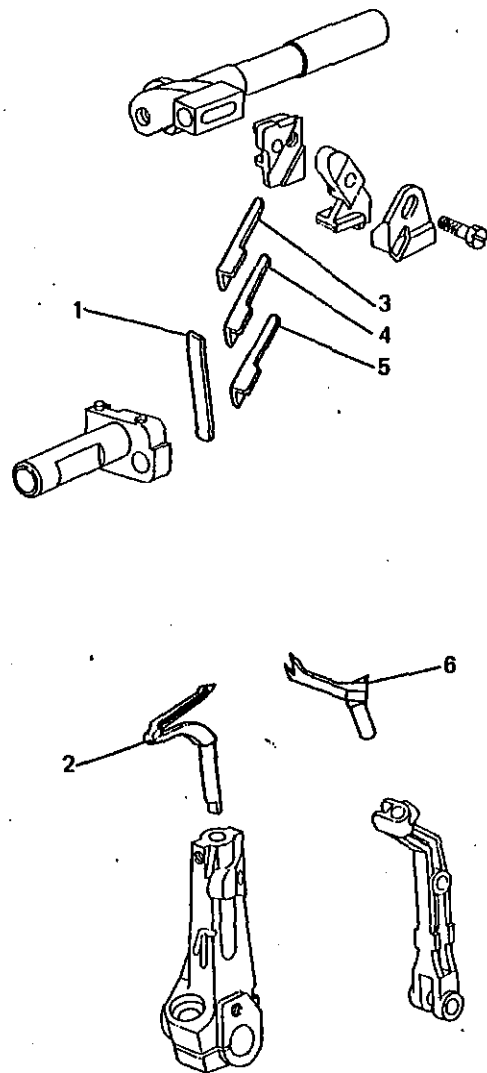

From the library of: Diamond Needle Corp

Fig. N.	Part. N. Piece N.	Qt.
1	207020-2-01	1
2	209268-0-00	1
3	209355-0-00	1
4	209357-0-00	1
5	209358-0-00	1
6	211247-0-00	1

1

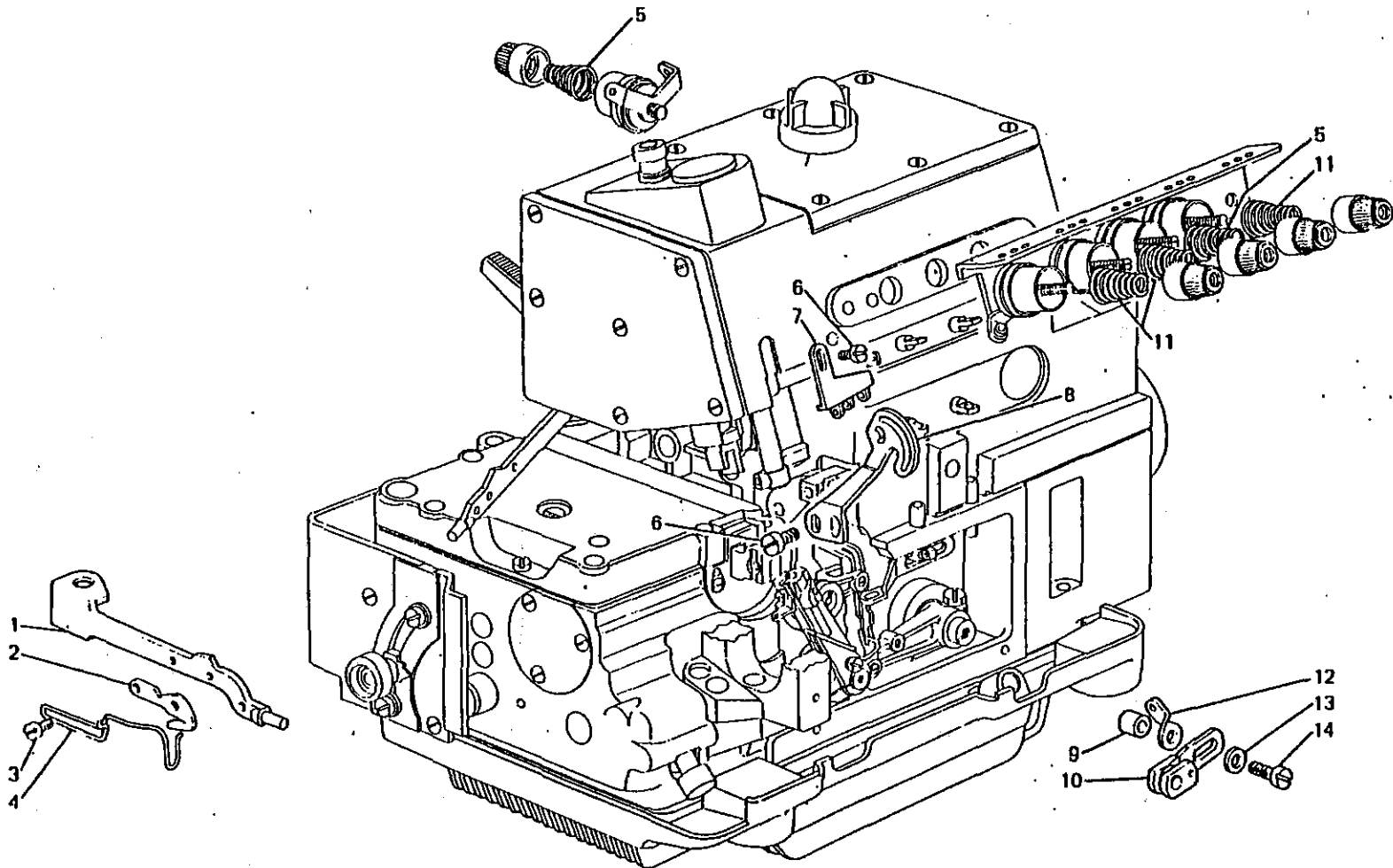
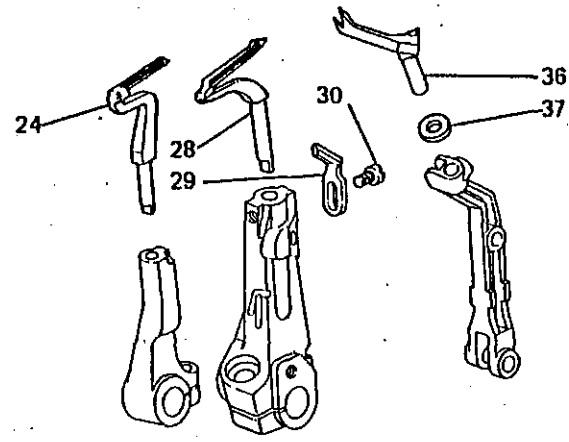
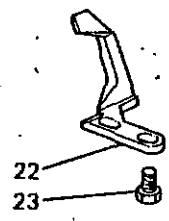
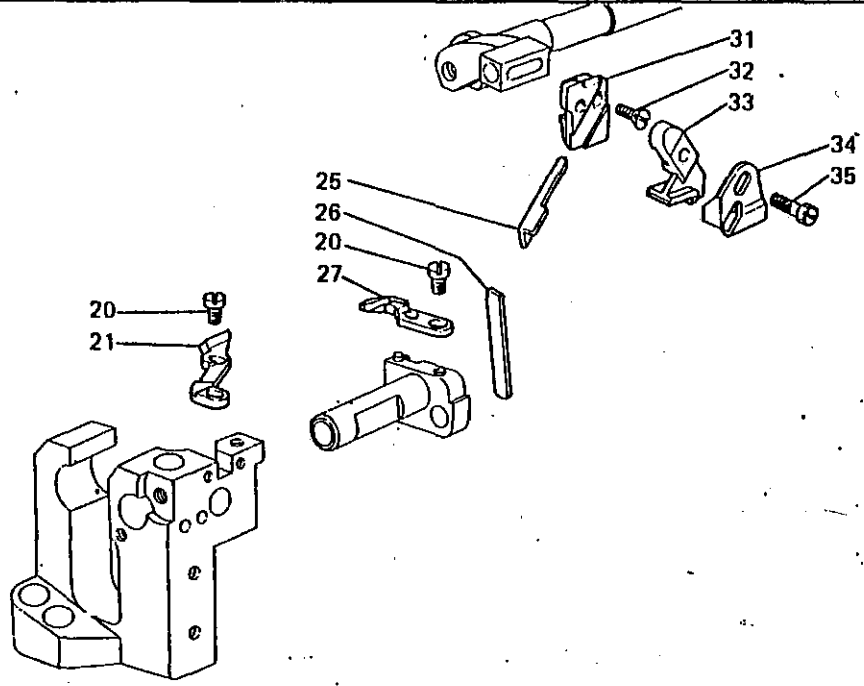
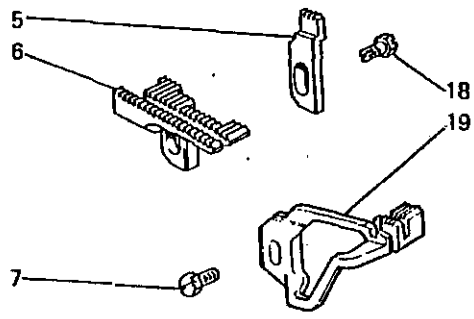
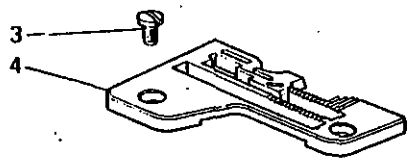
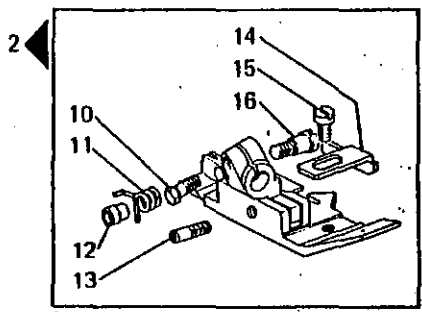
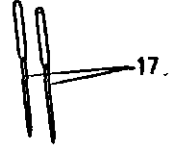
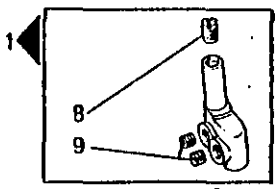

Fig. #.	Part N. Piece N.	Qt.
1	209511-0-00	1
2	202194-0-11	1
3	741433-2-00	2
4	991612-0-00	1
5	202681-0-10	2
6	741558-0-00	3
7	211143-0-00	1
8	211146-0-00	1
9	211742-0-00	1
10	211743-0-00	1
11	202227-0-10	3
12	211748-0-00	1
13	704104-2-00	1
14	722440-2-00	1

From the library of: Diamond Needle Corp

SEQUE  
FOLLOWS

2



From the library of: Diamond Records Corp

Fig. N.	Part. N. Pieco N.	Qt.
1	207525-2-00	1
2	204828-3-11	1
3	744742-2-00	2
4	208041-0-01	1
5	204818-0-11	1
6	204818-0-11	1
7	202489-0-10	1
8	727021-0-00	1
9	745810-2-00	2
10	204947-0-10	1
11	204894-0-11	1
12	204895-0-11	1
13	204869-0-11	1
14	204880-0-11	1
15	741431-2-00	1
16	204889-0-10	1
17	765510-1-90	7
18	202488-0-10	1
19	208040-0-00	1
20	741531-2-00	2
21	209192-0-00	1
22	209279-0-00	1
23	740230-2-00	2
24	211310-0-00	1
25	209356-0-00	2
26	204693-0-11	2
27	209188-0-00	1
28	209264-0-10	1
29	209261-0-00	1
30	741538-2-00	1
31	207650-0-01	1
32	744573-0-00	1
33	207653-0-01	1
34	211137-0-00	1
35	207417-0-01	1
36	211247-0-00	1
37	211301-0-00	1

SEGUE  
FOLLOWS

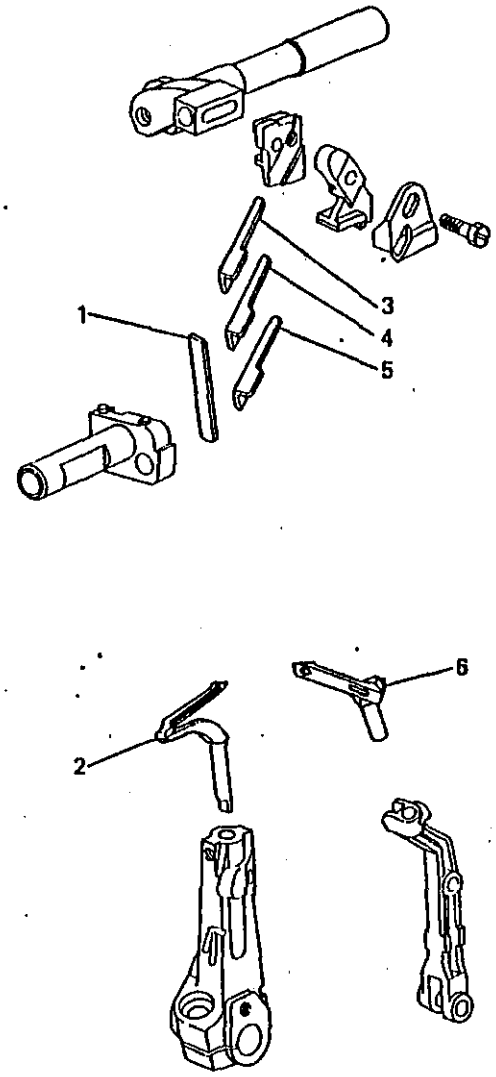

Rim®

Fig. N.	Part N. Piece N.	Qt.
1	207020-2 01	1
2	209268-0-00	1
3	209355-0-00	1
4	209357-0-00	1
5	209358-0-00	1
6	211248-0-00	1

From the library of: Diamond Needle Corp

1

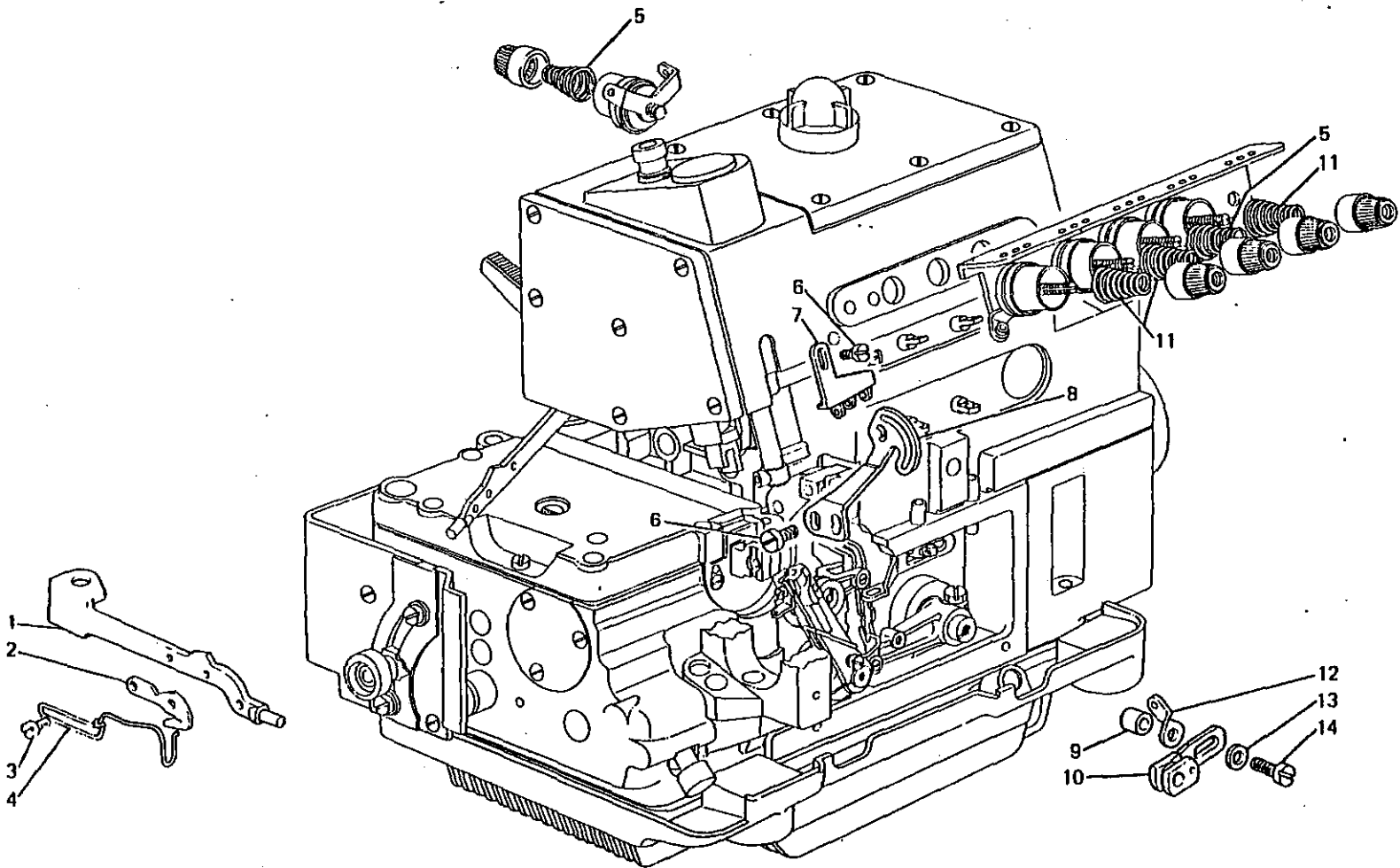
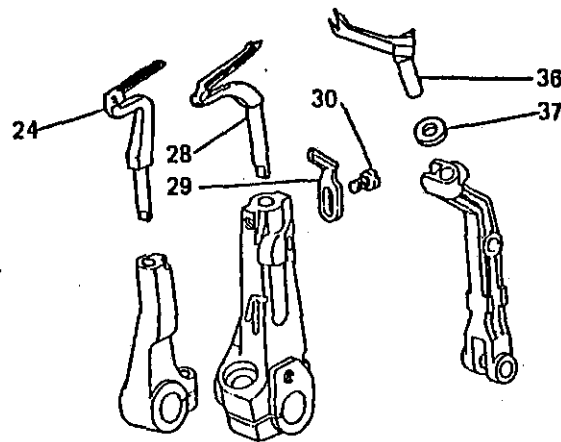
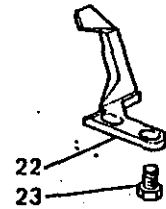
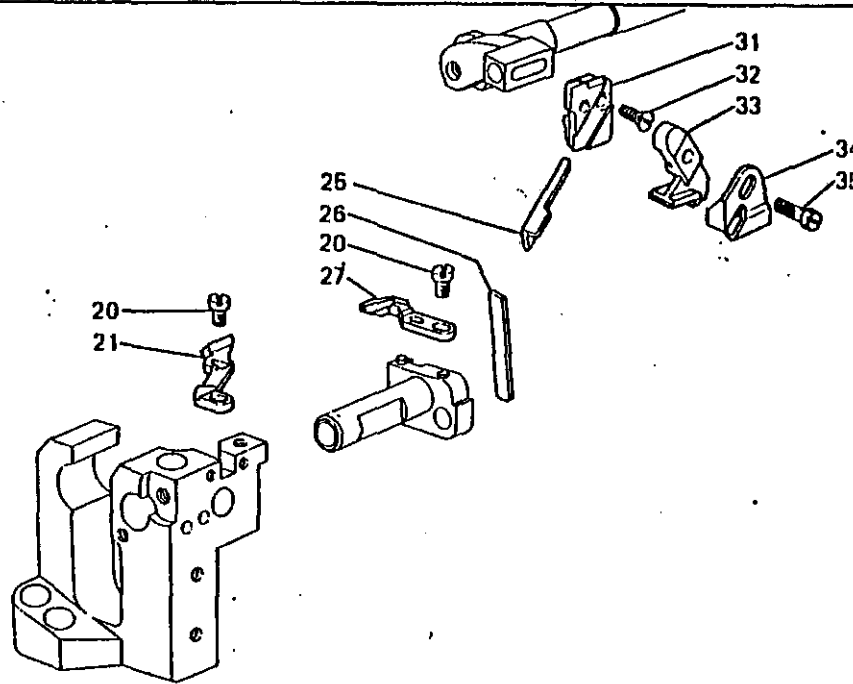
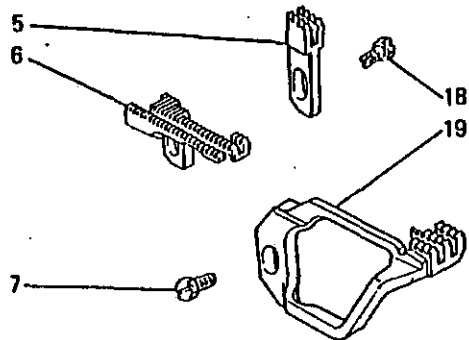
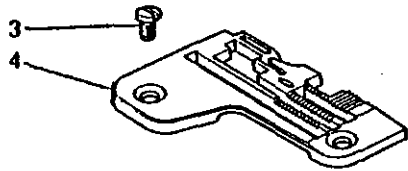
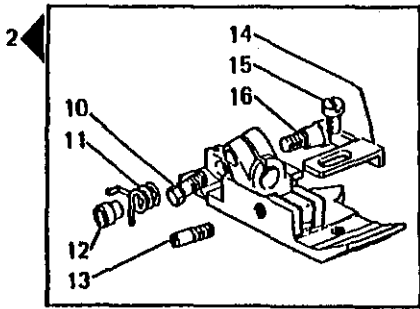
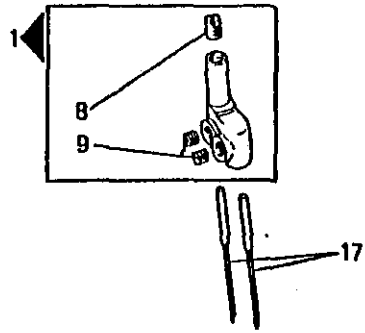

Fig. N.	Part N. Piece N.	Qt.
1	209511-0-00	1
2	202194-0-11	1
3	741433-2-00	2
4	991612-0-00	1
5	202681-0-10	2
6	741558-0-00	3
7	211143-0-00	1
8	211146-0-00	1
9	211742-0-00	1
10	211743-0-00	1
11	202227-0-10	3
12	211748-0-00	1
13	704104-2-00	1
14	722440-2-00	1

From the library of Diamond Needle Corp

SEGUE  
FOLLOWS



From the library of Diamond Needle Corp.

Fig. N.	Part N. Piece N.	Qt.
1	207524-2-00	1
2	204875-3-12	1
3	744742-2-00	2
4	208043-0-02	1
5	202609-0-10	1
6	208053-0-10	1
7	202489-0-10	1
8	727021-0-00	1
9	745810-2-00	2
10	204947-0-10	1
11	204894-0-11	1
12	204895-0-11	1
13	204869-0-11	1
14	204880-0-11	1
15	741431-2-00	1
16	204889-0-10	1
17	765510-1-10	7
18	202488-0-10	1
19	208042-0-10	1
20	741531-2-00	2
21	209192-0-00	1
22	209279-0-00	1
23	740230-2-00	2
24	211310-0-00	1
25	209356-0-00	2
26	204693-0-11	2
27	209185-0-00	1
28	209264-0-10	1
29	209261-0-00	1
30	741538-2-00	1
31	207650-0-01	1
32	744573-0-00	1
33	207653-0-01	1
34	211137-0-00	1
35	207417-0-01	1
36	211247-0-00	1
37	211301-0-00	1

SEGUE  
FOLLOWS

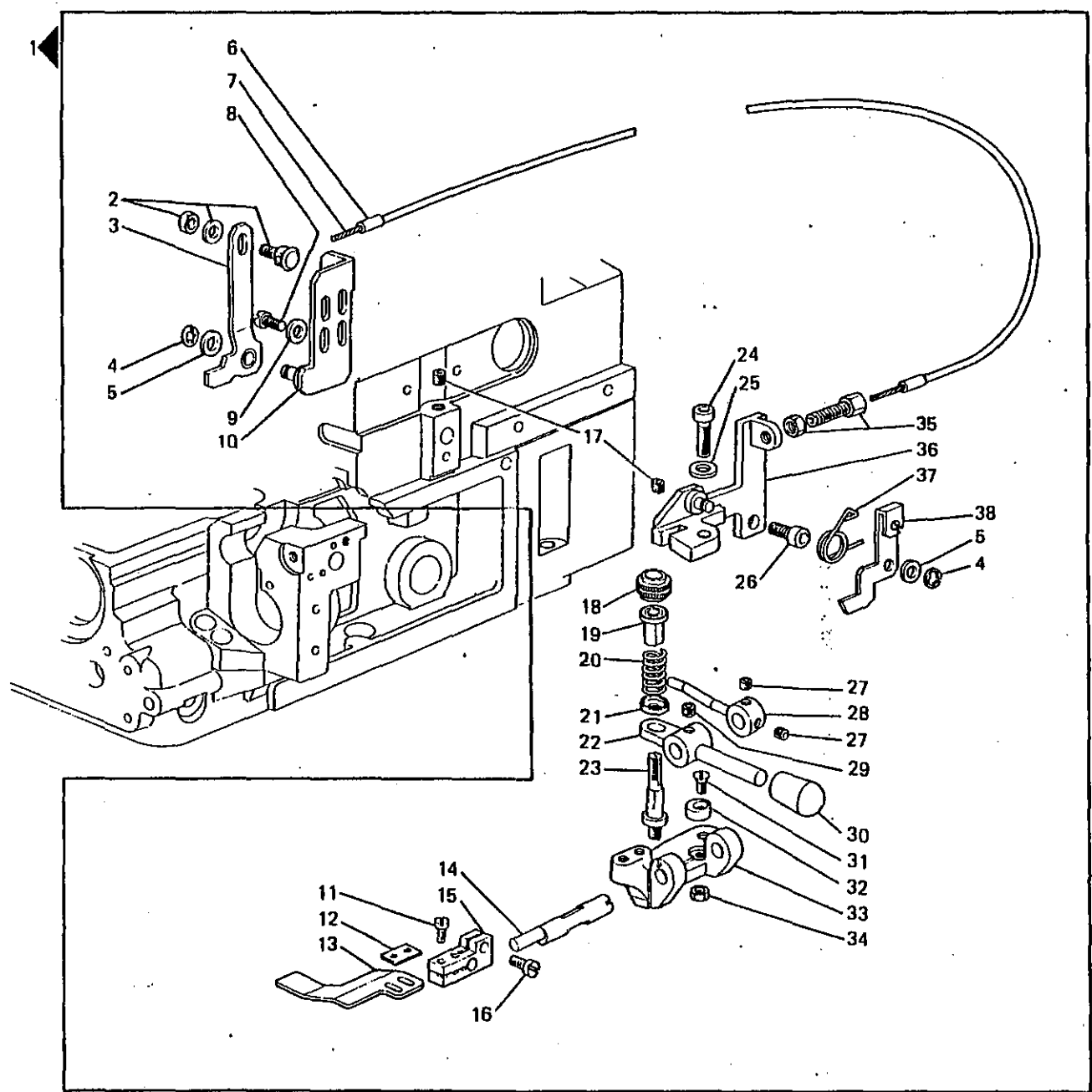

From the library of: Diamond Needle Corp

Fig. N.	Part. N. Piece N.	Qt.
1	211643-4-00	1
2	210135-0-00	1
3	921975-0-10	1
4	700207-0-00	2
5	704108-2-00	2
6	310612-0-00	1
7	210132-2-00	1
8	721474-2-00	2
9	704106-2-00	2
10	921973-0-10	1
11	741675-2-00	2
12	204964-0-00	1
13	210181-0-00	1
14	210177-0-00	1
15	210180-2-10	1
16	721464-2-00	1
17	729023-2-00	1
18	200699-0-10	1
19	200074-0-10	1
20	204937-0-10	1
21	200821-0-10	1
22	210179-0-00	1
23	200698-0-10	1
24	722483-2-00	1
25	702412-0-00	1
26	722433-2-00	1
27	729012-2-00	2
28	211645-0-00	1
29	729013-2-00	1
30	210182-0-00	1
31	724054-0-00	1
32	300710-0-10	1
33	211644-0-00	1
34	746204-2-00	1
35	210130-0-00	1
36	211646-0-00	1
37	210174-0-00	1
38	210173-0-00	1

SEGUE  
FOLLOWS

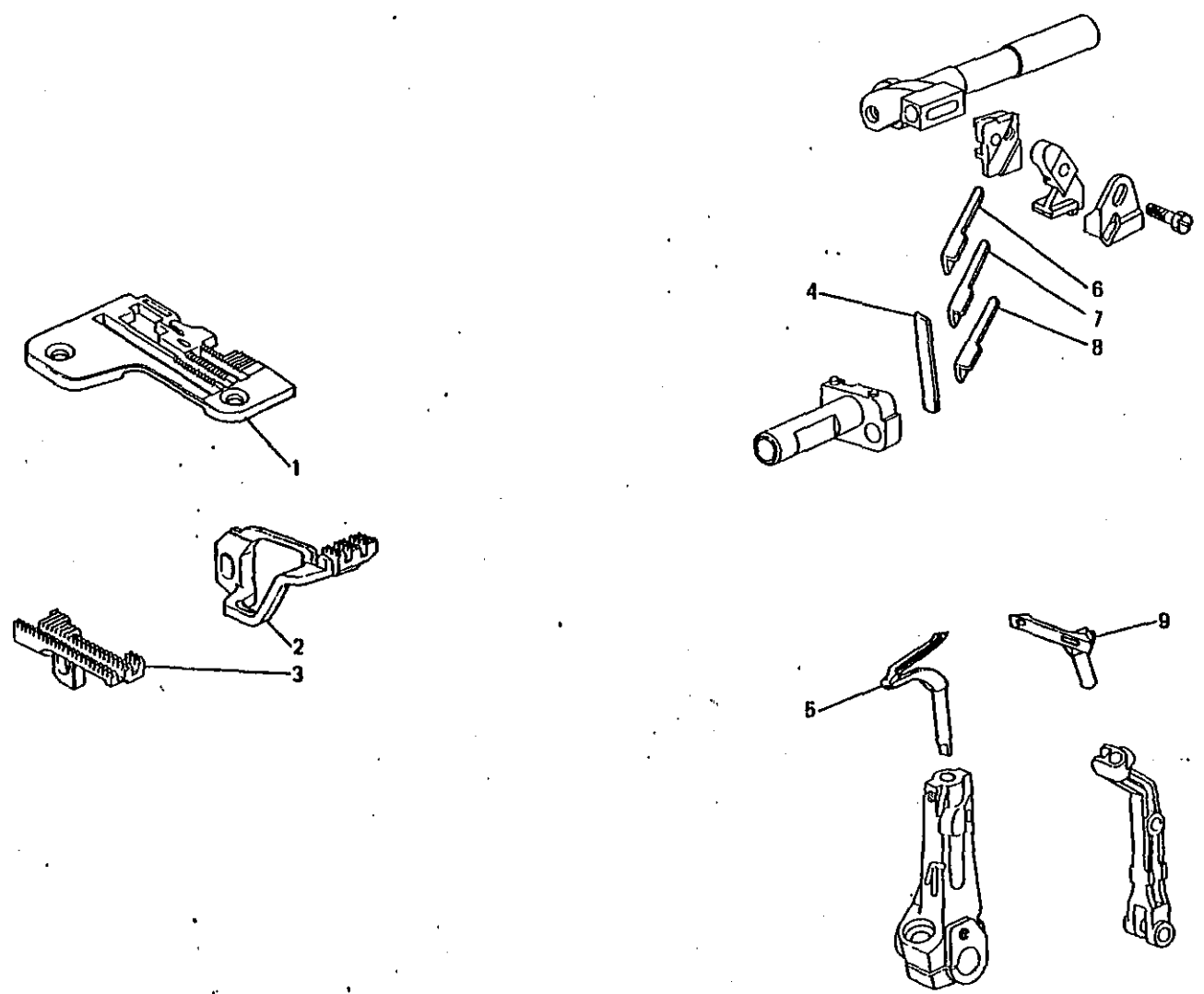

From the library of: Diamond Needle Corp

Fig. N.	Part. N. Piece N.	Qt.
1	208045-0-02	1
2	208044-0-10	1
3	208054-0-10	1
4	207020-2-01	1
5	209268-0-00	1
6	209355-0-00	1
7	209357-0-00	1
8	209358-0-00	2
9	211248-0-00	1



1

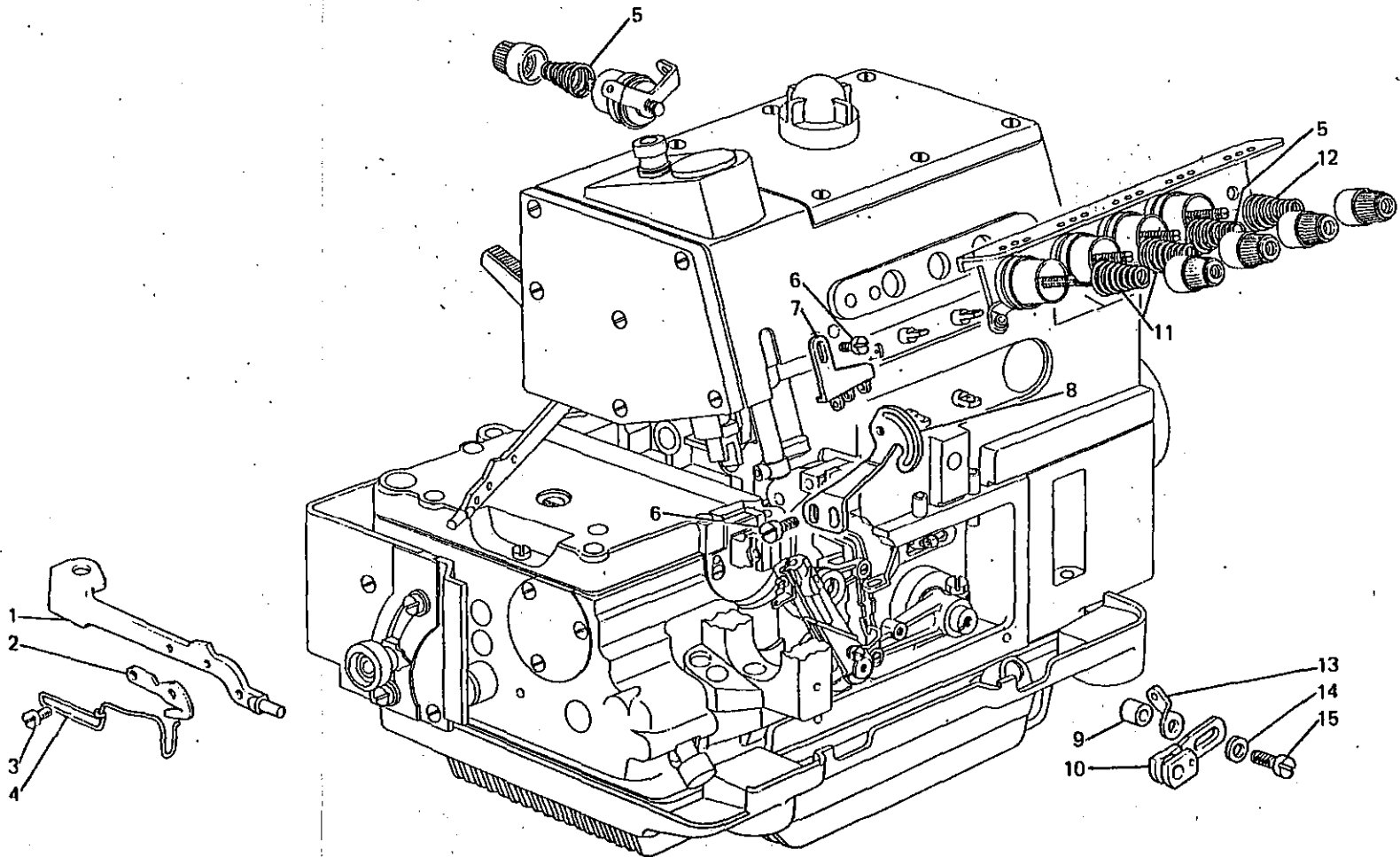

From the library of Engineering Resources Corp.

Fig. N.	Part N. Piece N.	Ql.
1	209511-0-00	1
2	202194-0-11	1
3	741433-2-00	2
4	991612-0-00	1
5	202681-0-10	2
6	741558-0-00	3
7	211144-0-00	1
8	211145-0-00	1
9	211742-0-00	1
10	211743-0-00	1
11	202227-0-10	2
12	202228-0-10	1
13	211748-0-00	1
14	704104-2-00	1
15	722440-2-00	1

SEGUE  
FOLLOWS

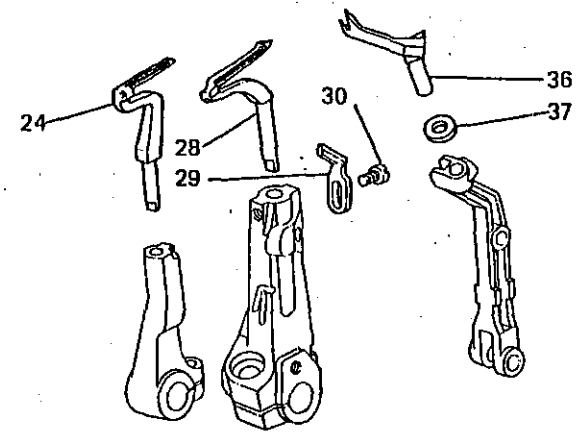
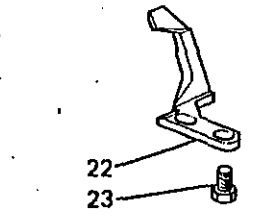
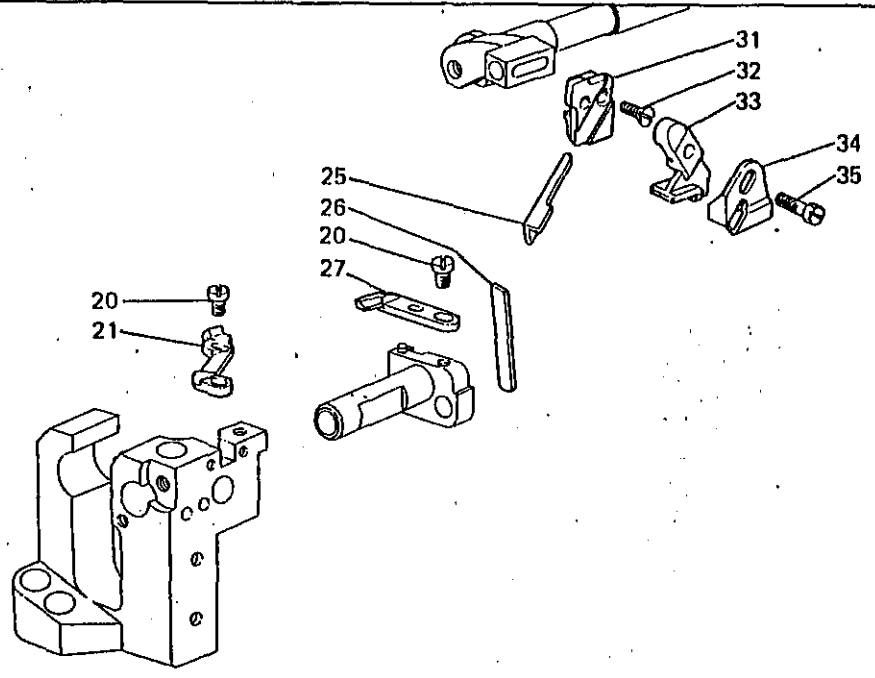
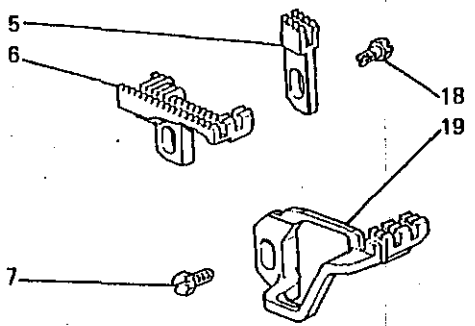
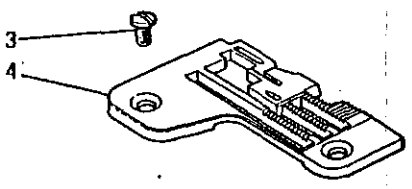
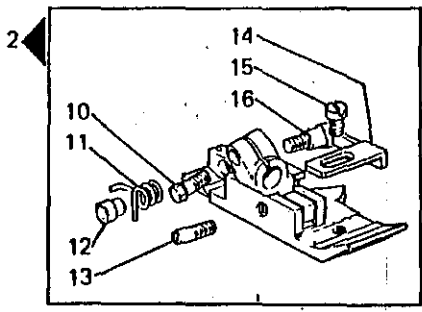
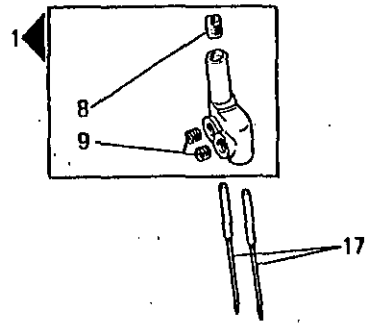
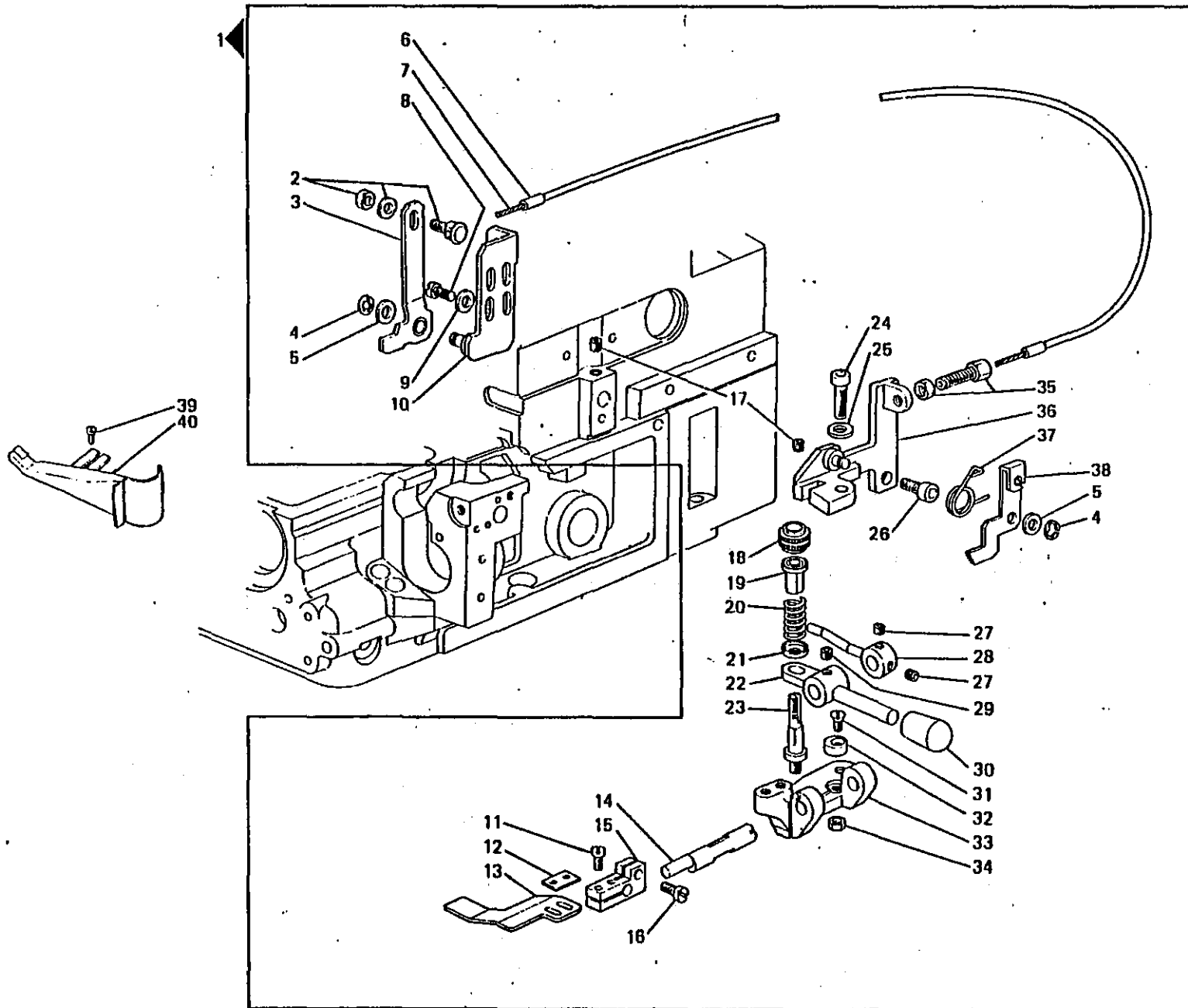

Fig. N.	Part. N. Piece N.	Qt.
1	207526-2-00	1
2	205034-3-12	1
3	744742-2-00	2
4	208048-0-10	1
5	202609-0-10	1
6	208052-0-10	1
7	202489-0-10	1
8	727021-0-00	1
9	745810-2-00	2
10	204947-0-10	1
11	204894-0-11	1
12	204895-0-11	1
13	204869-0-11	1
14	204880-0-11	1
15	741431-2-00	1
16	204889-0-10	1
17	765510-1-10	7
18	202488-0-10	1
19	208051-0-10	1
20	741531-2-00	2
21	209945-0-00	1
22	209279-0-00	1
23	740230-2-00	2
24	211310-0-00	1
25	209352-0-00	2
26	204693-0-11	2
27	209194-0-00	1
28	209264-0-10	1
29	209261-0-00	1
30	741538-2-00	1
31	207650-0-01	1
32	744573-0-00	1
33	207653-0-01	1
34	211137-0-00	1
35	207417-0-01	1
36	211247-0-00	1
37	211302-0-00	1

From the library of: Diamond Needle Corp

SEGUE  
FOLLOWS



From the library of Diamond Needle Corp

Fig. N.	Part. N. Piece N.	Qt.
1	211643-4-00	1
2	210135-0-00	1
3	921975-0-10	1
4	700207-0-00	2
5	704108-2-00	2
6	310812-0-00	1
7	210132-2-00	1
8	721474-2-00	2
9	704106-2-00	2
10	921973-0-10	1
11	741675-2-00	2
12	204964-0-00	1
13	210181-0-00	1
14	210177-0-00	1
15	210180-2-10	1
16	721464-2-00	1
17	729023-2-00	1
18	200699-0-10	1
19	200074-0-10	1
20	204937-0-10	1
21	200821-0-10	1
22	210179-0-00	1
23	200698-0-10	1
24	722483-2-00	1
25	702412-0-00	1
26	722433-2-00	1
27	729012-2-00	2
28	211645-0-00	1
29	729013-2-00	1
30	210182-0-00	1
31	724054-0-00	1
32	300710-0-10	1
33	211644-0-00	1
34	746204-2-00	1
35	210130-0-00	1
36	211648-0-00	1
37	210174-0-00	1
38	210173-0-00	1

SEQUE  
FOLLOWS

**CARATTERISTICHE E FUNZIONI DEI PARTICOLARI A RICHIESTA**  
**CHARACTERISTICS AND FUNCTIONS OF REQUESTED SPARE PARTS**  
**CARACTERISTIQUES ET FONCTIONS DES REFERENCES SUR DEMANDE**  
**KENNZEICHEN UND FUNKTIONEN DER TEILE AUF ANFRAGE**  
**CARACTERISTICAS Y FUNCIONES DE LOS REPUESTOS POR SOLICITUD**

021/4

Fig. N.	X	Y	DESCRIZIONE	DESCRIPTION	DESCRIPTION	BENENNUNG	DESCRIPCION
1		2					
2*		2					
3		2					
4*		2					
5		W					
6			Crochet foro ø 0,7.	Looper hole ø 0,7.	Crochet trou ø 0,7.	Graifer Bohrung ø 0,7.	Garfo orificio ø 0,7.
7		W					
8		WD					
9		AD					
10			Crochet foro ø 0,7.	Looper hole ø 0,7.	Crochet trou ø 0,7.	Graifer Bohrung ø 0,7.	Garfo orificio ø 0,7.

From the library of: Diamond Needle Corp

X	-	LARGHEZZA COSTA	WIDTH OF BIGHT	LARGEUR DE SURJET	UEBERWENDLICHBREITE	ANCHO COSTURA
Y	-	PASSO/FINITURA	DISTANCE/FINISHING	PAS/FINITION	TEILUNG/BEHANDLUNG	PASO/ACABADO
A	-	ACCIAIO	STEEL	ACIER	STAHL	ACERO
D	-	DENTATO	TOOTHED	DENTE	GEZAEHNT	DENTADO
G	-	GOMMATA	RUBBERED	CAOUTCHOUTEE	GUMMIBELEGTEN	ENGOMADO
W	-	WIDIA	WIDIA	WIDIA	WIDIA	WIDIA
* ▲ ■ ●	-	ABBINAMENTI OBBLIGATORI	FIXED COUPLINGS	JUMELAGES OBLIGES	PFLICHT KOPPELUNGEN	COMBINACIONES OBLIGATORIAS

Rim®

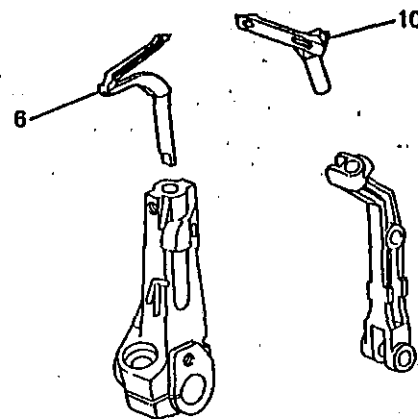
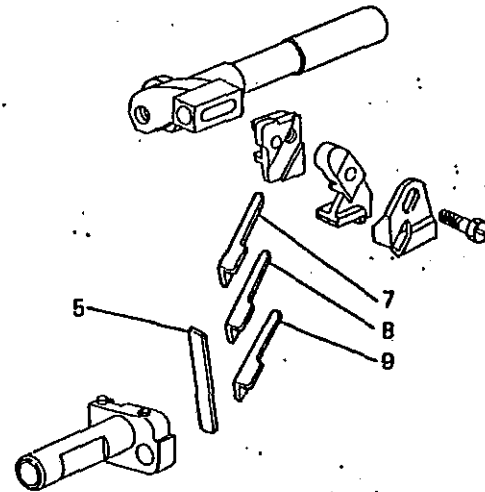
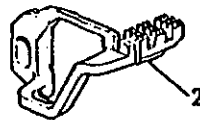
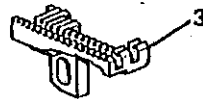
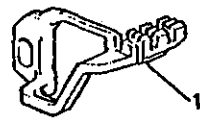
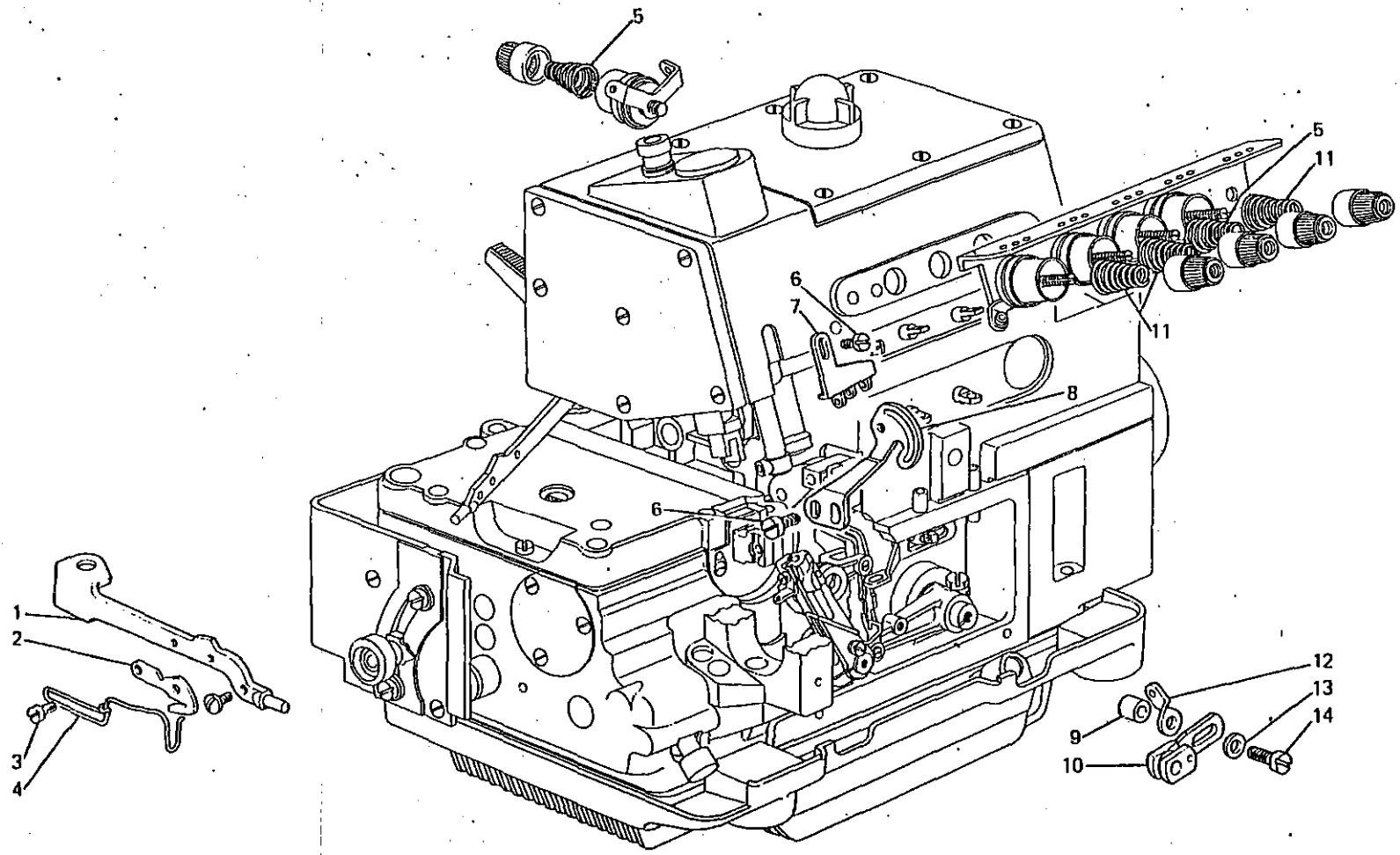

Fig. N.	Part. N. Piece N.	Qt.
1	208046-0-10	1
2	208049-0-10	1
3	208047-0-10	1
4	208050-0-10	1
5	207020-2-01	1
6	209268-0-00	1
7	209351-0-00	1
8	209353-0-00	1
9	209354-0-00	2
10	211248-0-00	1

From the library of Diamond Needle Corp

1



From the library of: Diamond Needle Corp.

Fig. N.	Part N. Piece N.	Qt.
1	209511-0-00	1
2	202194-0-11	1
3	741433-2-00	2
4	991612-0-00	1
5	202681-0-10	2
6	741558-0-00	3
7	211143-0-00	1
8	211145-0-00	1
9	211742-0-00	1
10	211743-0-00	1
11	202227-0-10	3
12	211748-0-00	1
13	704104-2-00	1
14	722440-2-00	1

SEGUE  
FOLLOWS

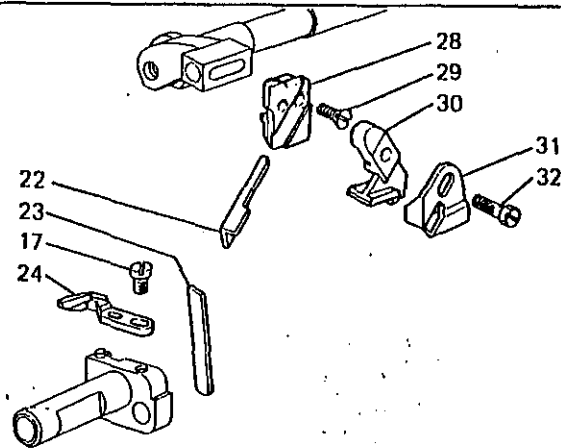
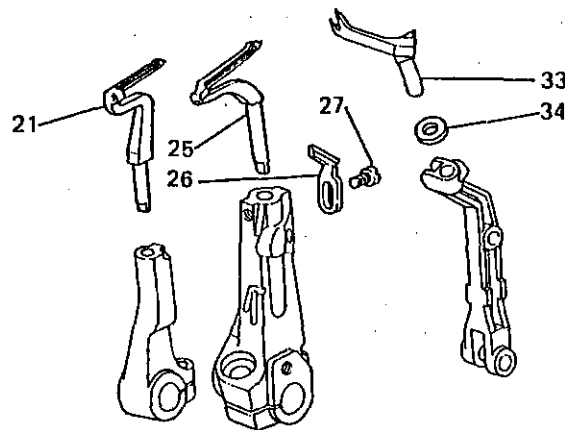
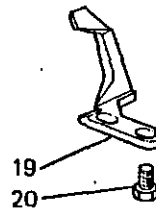
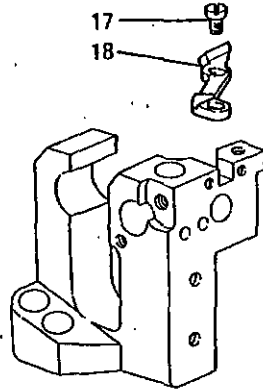
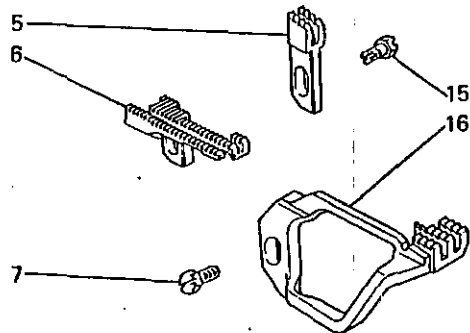
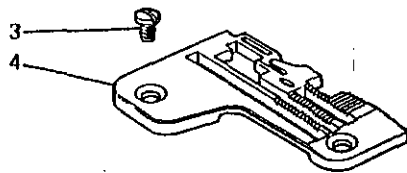
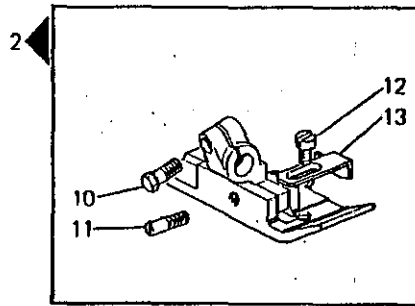
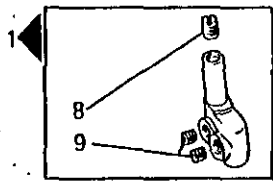

From the library of: Diamond Needle Corp

Fig. N.	Part. N. Piece N.	Qt.
1	207524-2-00	1
2	204876-3-12	1
3	744742-2-00	2
4	208043-0-02	1
5	202609-0-10	1
6	208053-0-10	1
7	202489-0-10	1
8	727021-0-00	1
9	745810-2-00	2
10	204947-0-10	1
11	204869-0-11	1
12	741431-2-00	1
13	204881-0-10	1
14	765510-1-10	7
15	202488-0-10	1
16	208042-0-10	1
17	741531-2-00	2
18	209192-0-00	1
19	209279-0-00	1
20	740230-2-00	2
21	211310-0-00	1
22	209356-0-00	2
23	204693-0-11	2
24	209195-0-00	1
25	209264-0-10	1
26	209261-0-00	1
27	741538-2-00	1
28	207650-0-01	1
29	744573-0-00	1
30	207653-0-01	1
31	211137-0-00	1
32	207417-0-01	1
33	211247-0-00	1
34	211301-0-00	1

SEQUE  
FOLLOWS

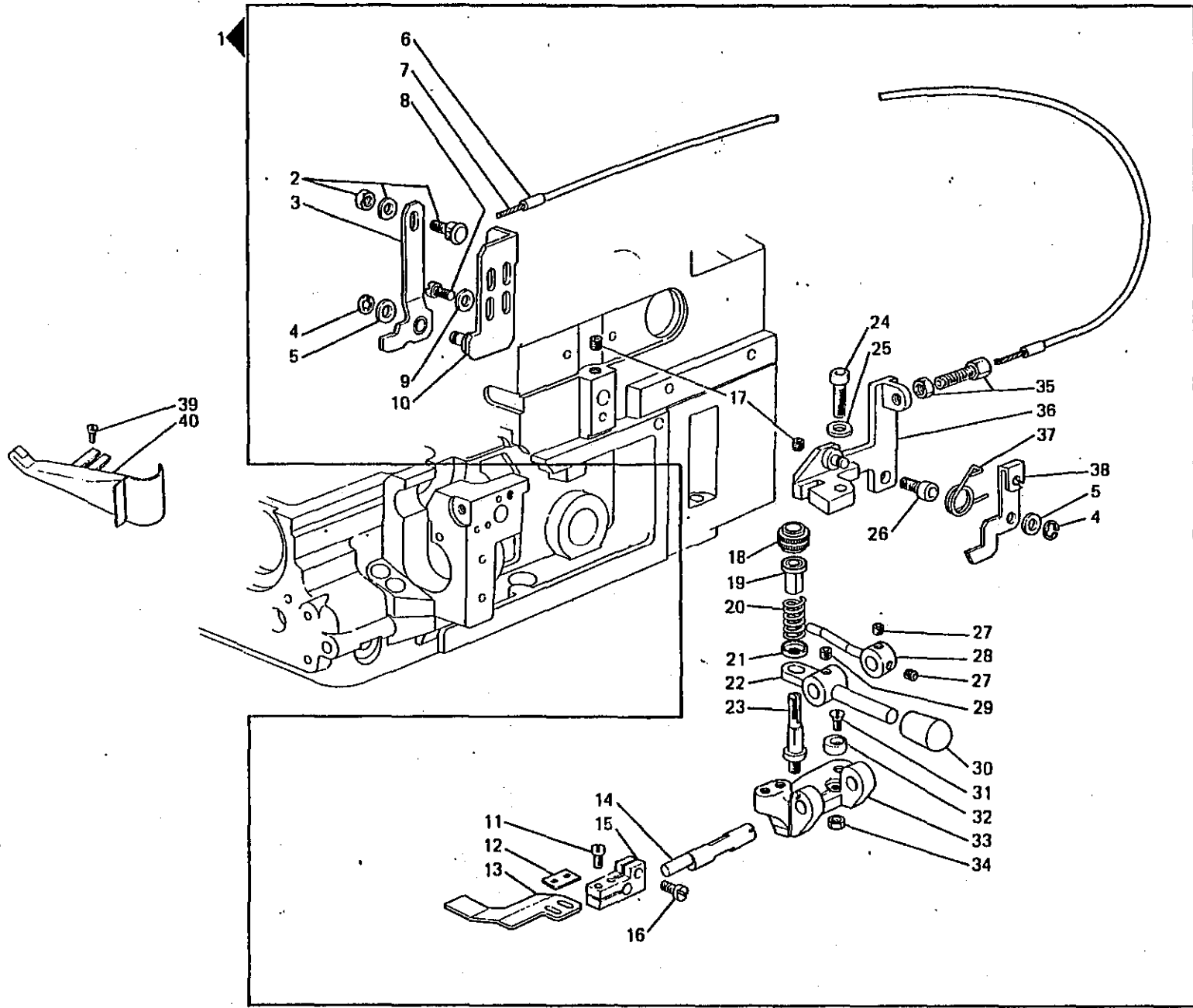

Fig. N.	Part N. Piece N.	Qt.
1	211643-4-00	1
2	210135-0-00	1
3	921975-0-10	1
4	700207-0-00	2
5	704108-2-00	2
6	310612-0-00	1
7	210132-2-00	1
8	721474-2-00	2
9	704106-2-00	2
10	921973-0-10	1
11	741675-2-00	2
12	204964-0-00	1
13	210181-0-00	1
14	210177-0-00	1
15	210180-2-10	1
16	721464-2-00	1
17	729023-2-00	1
18	200699-0-10	1
19	200074-0-10	1
20	204937-0-10	1
21	200821-0-10	1
22	210179-0-00	1
23	200698-0-10	1
24	722483-2-00	1
25	702412-0-00	1
26	722433-2-00	1
27	729012-2-00	2
28	211645-0-00	1
29	729013-2-00	1
30	210182-0-00	1
31	724054-0-00	1
32	300710-0-10	1
33	211644-0-00	1
34	746204-2-00	1
35	210130-0-00	1
36	211646-0-00	1
37	210174-0-00	1
38	210173-0-00	1
39	721444-2-00	1
40	204930-2-10	1

From the library of: Diamond Needle Corp

SEGUE  
FOLLOWS



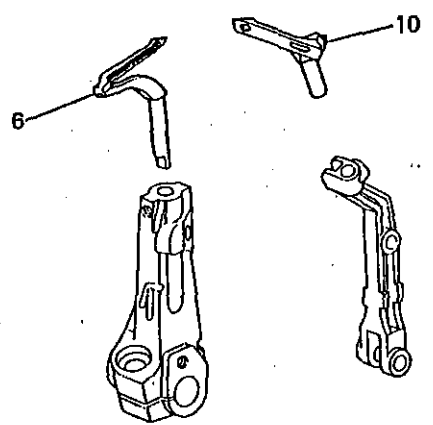
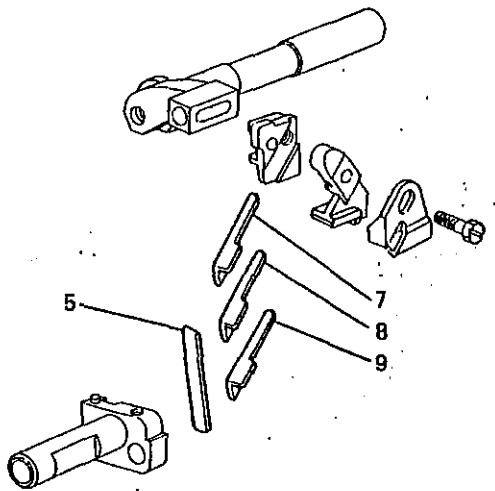
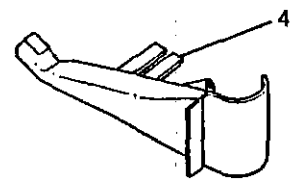
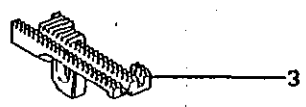
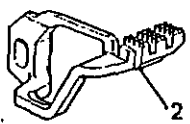
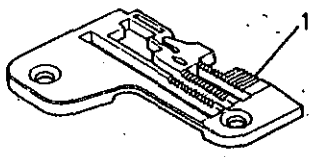
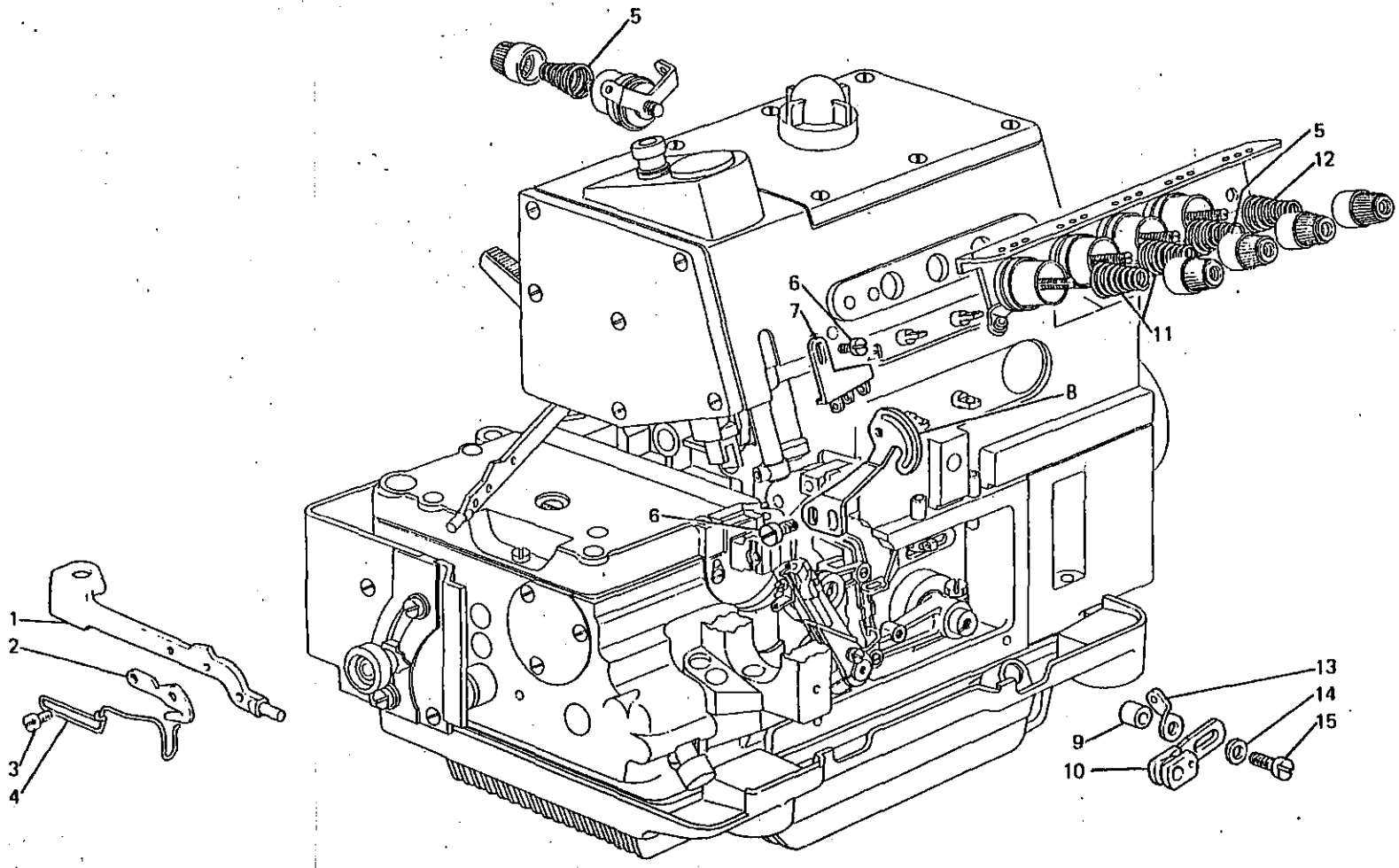

Fig. N.	Part. N. Piece N.	Qt.
1	208045-0-02	1
2	208044-0-10	1
3	208054-0-10	1
4	204958-2-10	1
5	207020-2-01	1
6	209268-0-00	1
7	209355-0-00	1
8	209357-0-00	1
9	209358-0-00	1
10	211248-0-00	1

From the library of: Diamond Needle Corp

1



From the library of: Diamond Needle Corp

Fig. N.	Part. N. Piceo N.	Qt.
1	209511-0-00	1
2	202194-0-11	1
3	741433-2-00	2
4	991612-0-00	1
5	202681-0-10	2
6	741558-0-00	3
7	211144-0-00	1
8	211145-0-00	1
9	211742-0-00	1
10	211743-0-00	1
11	202227-0-10	2
12	202228-0-10	1
13	211748-0-00	1
14	704104-2-00	1
15	722440-2-00	1

SEQUE  
FOLLOWS

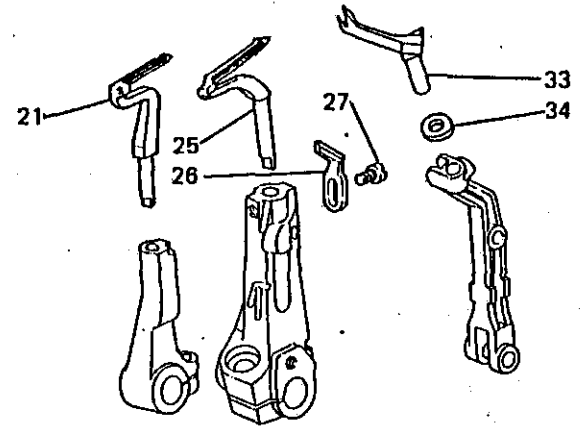
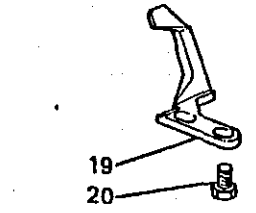
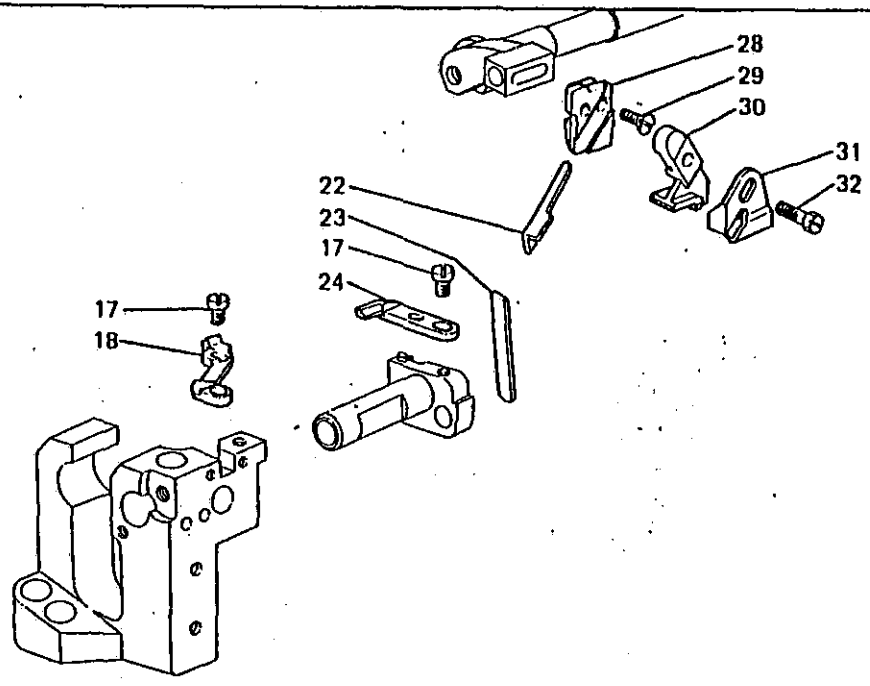
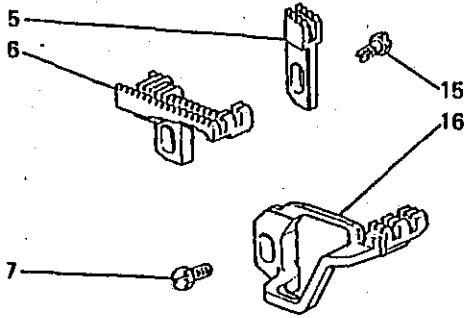
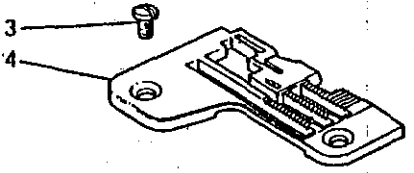
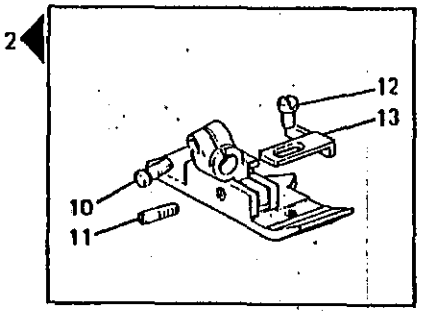
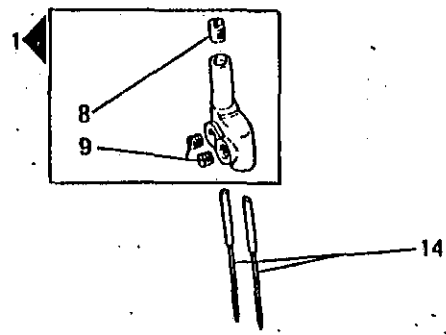

From the library of Diamond Needle Corp

Fig. N.	Part. N. Piece N.	Qt.
1	207526-2-00	1
2	205035-3-12	1
3	744742-2-00	2
4	208048-0-10	1
5	202609-0-10	1
6	208052-0-10	1
7	202489-0-10	1
8	727021-0-00	1
9	745810-2-00	2
10	204947-0-10	1
11	204869-0-11	1
12	741431-2-00	1
13	204881-0-10	1
14	765510-1-10	7
15	202488-0-10	1
16	208051-0-10	1
17	741531-2-00	2
18	209945-0-00	1
19	209279-0-00	1
20	740230-2-00	2
21	211310-0-00	1
22	209352-0-00	2
23	204693-0-11	2
24	209194-0-00	1
25	209264-0-10	1
26	209261-0-00	1
27	741538-2-00	1
28	207650-0-01	1
29	744573-0-00	1
30	207653-0-01	1
31	211137-0-00	1
32	207417-0-01	1
33	211247-0-00	1
34	211302-0-00	1

SEQUE  
FOLLOWS

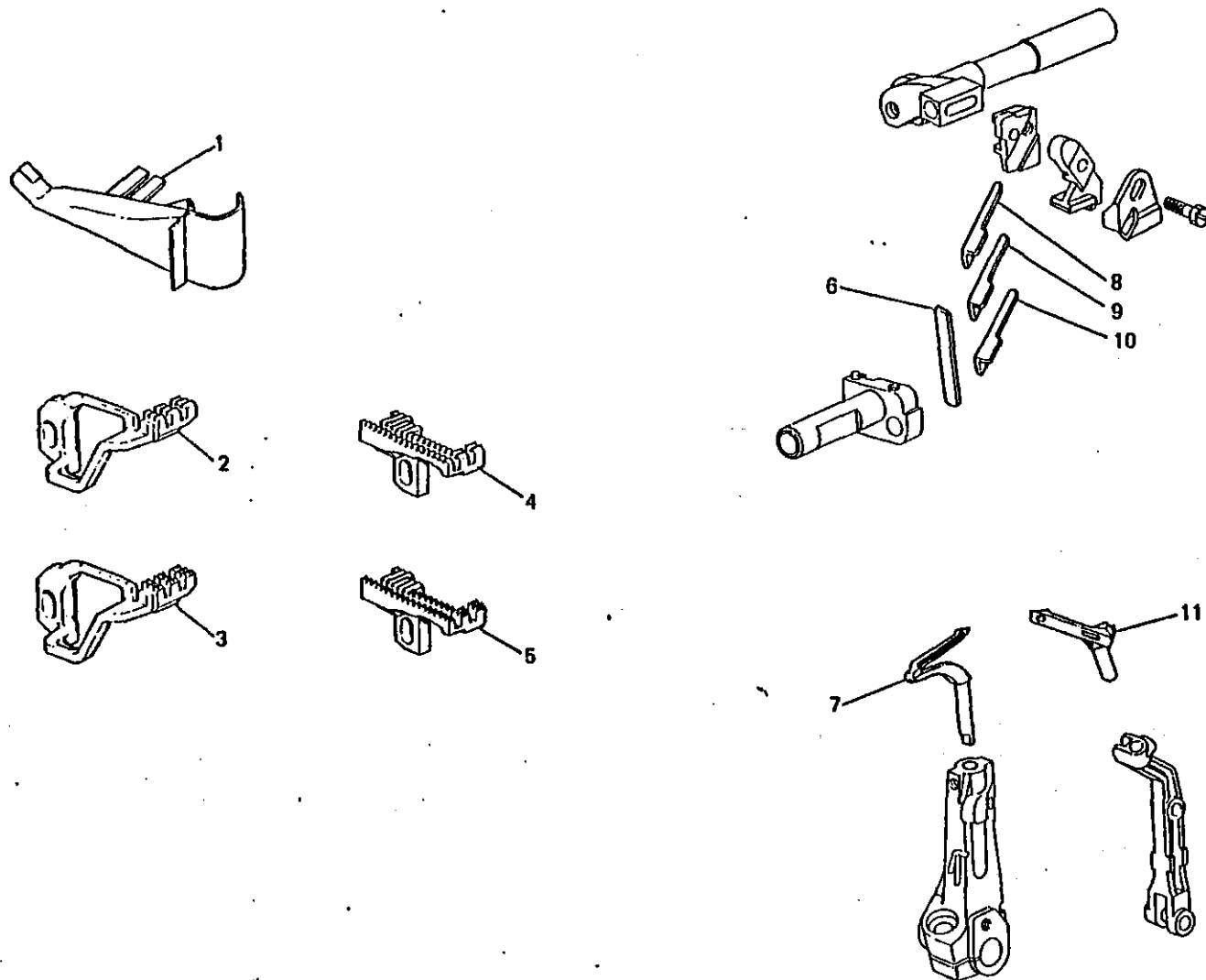

From the library of: Diamond Needle Corp

Fig. N.	Part N. Piece N.	Qt.
1	204958-2-10	1
2	208046-0-10	1
3	208049-0-10	1
4	208047-0-10	1
5	208050-0-10	1
6	207020-2-01	1
7	209268-0-00	1
8	209351-0-00	1
9	209353-0-00	1
10	209354-0-00	2
11	211248-0-00	1

**CARATTERISTICHE E FUNZIONI DEI PARTICOLARI A RICHIESTA**  
**CHARACTERISTICS AND FUNCTIONS OF REQUESTED SPARE PARTS**  
**CARACTERISTIQUES ET FONCTIONS DES REFERENCES SUR DEMANDE**  
**KENNZEICHEN UND FUNKTIONEN DER TEILE AUF ANFRAGE**  
**CARACTERISTICAS Y FUNCIONES DE LOS REPUESTOS POR SOLICITUD**

023/4

Fig. N.	X	Y	DESCRIZIONE	DESCRIPTION	DESCRIPTION	BENENNUNG	DESCRIPCION
1			Per inserire cordoncino ø 3 mm. e fettuccia 20 mm.	For inserting piping cord ø 3 mm and tape 20 mm.	Pour introduire cordonnet ø 3 mm. et plié 20 mm.	Zur Einführung einer Kordel mit ø 3 mm und Verstärkungsbandes von 20 mm.	Para inserir cordón ø 3 mm. y cinta 20 mm.
2		2					
3*		2					
4		2					
5*		2					
6		W					
7		W	Crochet foro ø 0,7.	Looper hole ø 0,7.	Crochet trou ø 0,7.	Greifer Bohrung ø 0,7.	Garfo orificio ø 0,7.
8		W					
9		WD					
10		AD					
11			Crochet foro ø 0,7.	Looper hole ø 0,7.	Crochet trou ø 0,7.	Greifer Bohrung ø 0,7.	Garfo orificio ø 0,7.

From the library of: Diamond Needle Co.

X	=	LARGHEZZA COSTA	WIDTH OF BIGHT	LARGEUR DE SURJET	UEBERWENDLICHBREITE	ANCHO COSTURA
Y	=	PASSO/FINITURA	DISTANCE/FINISHING	PAS/FINITION	TEILUNG/BEHANDLUNG	PASO/ACABADO
A	=	ACCIAIO	STEEL	ACIER	STAHL	ACERO
D	=	DENTATO	TOOTHED	DENTE	GEZAEHNT	DENTADO
G	=	GOMMATA	RUBBERED	CAOUTCHOUTEE	GUMMIBELEGTEN	ENGOMADO
W	=	WIDIA	WIDIA	WIDIA	WIDIA	WIDIA
* ▲ ■ ●	=	ABBINAMENTI OBBLIGATORI	FIXED COUPLINGS	JUMELAGES OBLIGES	PFLICHT KOPPELUNGEN	COMBINACIONES OBLIGATORIAS

1

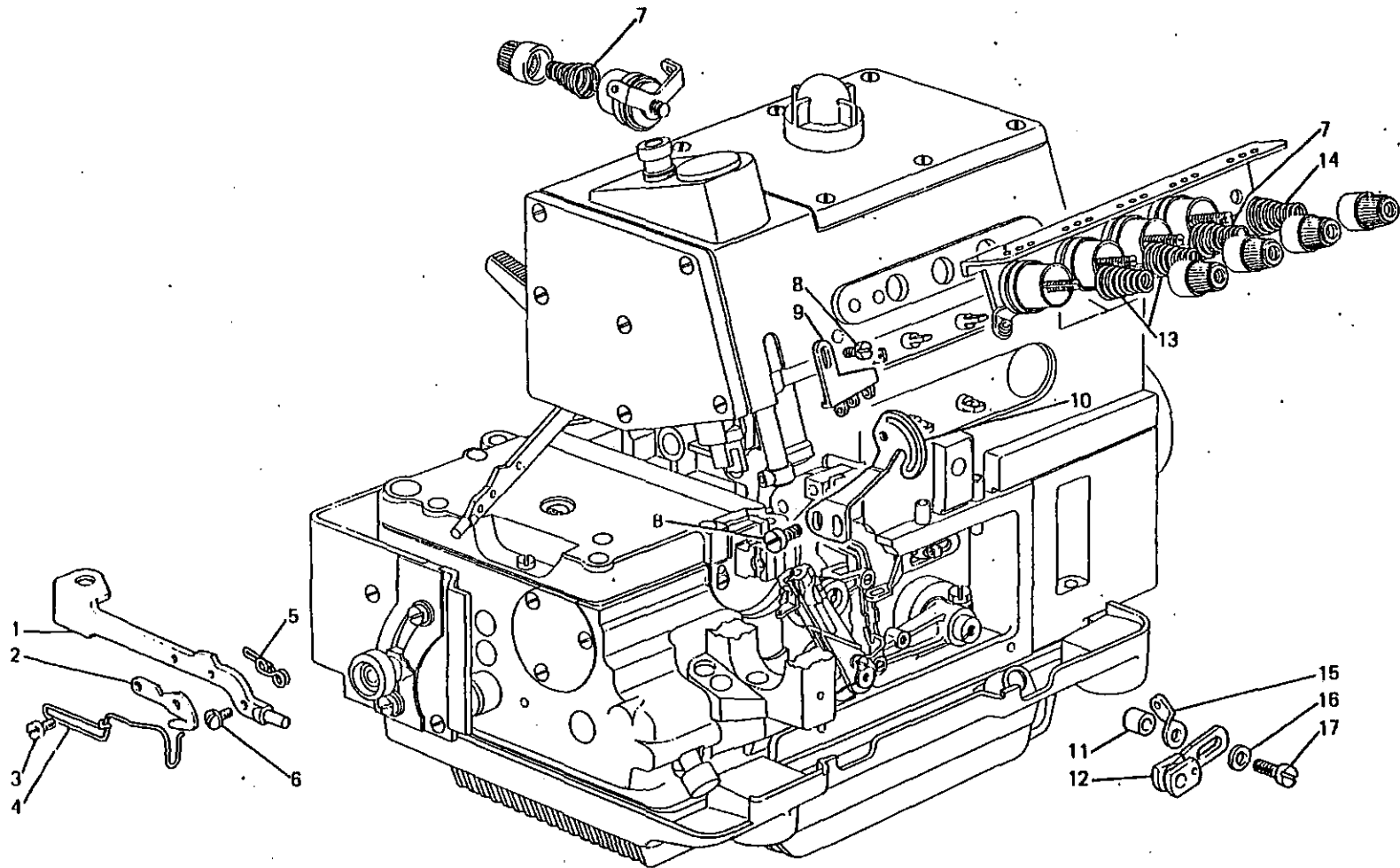
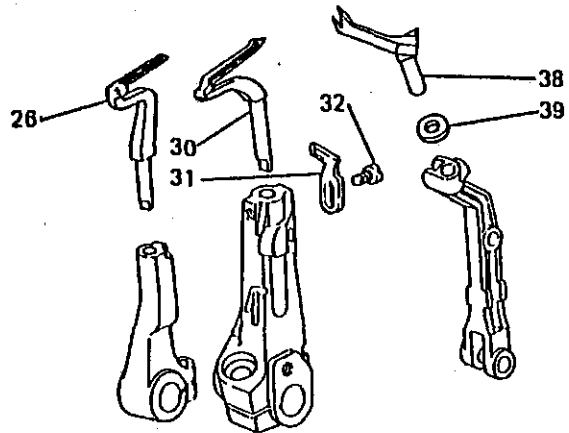
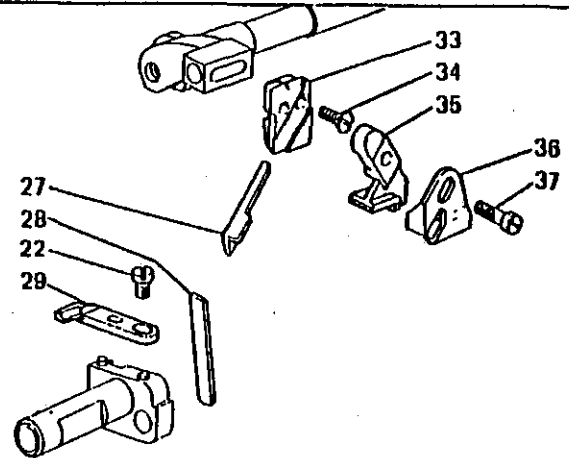
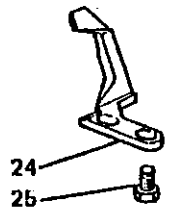
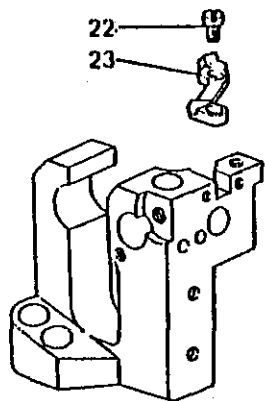
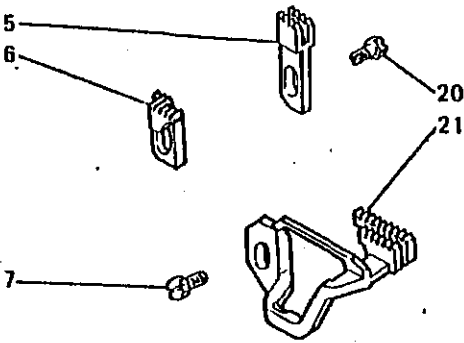
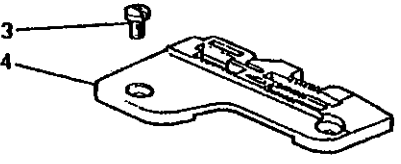
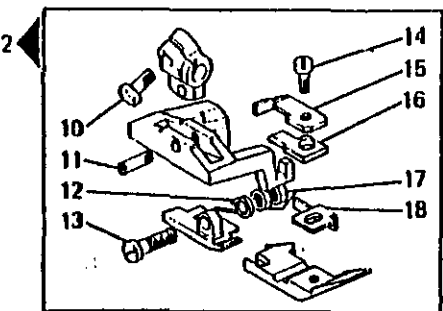
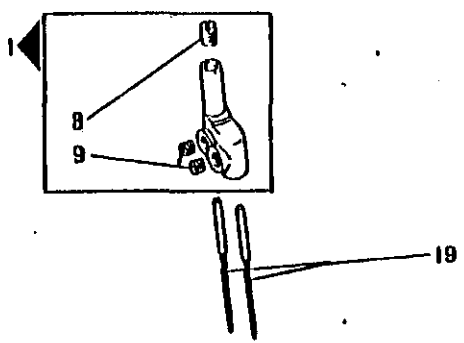

Fig. N.	Part. N. Piece N.	Qt.
1	209511-0-00	1
2	202194-0-11	1
3	741433-2-00	2
4	991611-0-00	1
5	204891-0-20	1
6	203187-0-10	1
7	202681-0-10	2
8	741558-0-00	3
9	211144-0-00	1
10	211145-0-00	1
11	211742-0-00	1
12	211743-0-00	1
13	202227-0-10	2
14	202228-0-10	1
15	211748-0-00	1
16	704104-2-00	1
17	722440-2-00	1

From the library of Diamond Needle Corp

SEGUE  
FOLLOWS



From the library of Diamond Firearms Corp.

Fig. N.	Part. N. Piece N.	Qt.
1	207526-2-00	1
2	207812-3-10	1
3	744742-2-00	2
4	207823-0-02	1
5	202609-0-10	1
6	207811-0-00	1
7	202489-0-10	1
8	727021-0-00	1
9	745810-2-00	2
10	204947-0-10	1
11	207822-0-00	1
12	207818-0-00	1
13	207817-0-00	1
14	741685-2-00	1
15	207824-0-00	1
16	207618-0-00	1
17	733503-2-00	1
18	207819-0-00	1
19	765515-1-12	7
20	202488-0-10	1
21	207810-0-01	1
22	741531-2-00	2
23	208945-0-00	1
24	209279-0-00	1
25	740230-2-00	2
26	211310-0-00	1
27	209351-0-00	1
28	207651-0-00	2
29	209194-0-00	1
30	209264-0-10	1
31	209281-0-00	1
32	741538-2-00	1
33	207650-0-01	1
34	744573-0-00	1
35	207653-0-01	1
36	211137-0-00	1
37	207417-0-01	1
38	211247-0-00	1
39	211302-0-00	1

SEQUE FOLLOWS

**CARATTERISTICHE E FUNZIONI DEI PARTICOLARI A RICHIESTA**  
**CHARACTERISTICS AND FUNCTIONS OF REQUESTED SPARE PARTS**  
**CARACTERISTIQUES ET FONCTIONS DES REFERENCES SUR DEMANDE**  
**KENNZEICHEN UND FUNKTIONEN DER TEILE AUF ANFRAGE**  
**CARACTERISTICAS Y FUNCIONES DE LOS REPUESTOS POR SOLICITUD**

024/3

Fig. N.	X	Y	DESCRIZIONE	DESCRIPTION	DESCRIPTION	BENENNUNG	DESCRIPCION
1		A WD AD	Crochet foro ø 0,7.	Looper hole ø 0,7.	Crochet trou ø 0,7.	Greller Bohrung ø 0,7.	Garfo orifido ø 0,7.
2							
3							
4							
5				Crochet foro ø 0,7.	Looper hole ø 0,7.	Crochet trou ø 0,7.	Greller Bohrung ø 0,7.

From the library of: Diamond Needle Corp

X	-	LARGHEZZA COSTA	WIDTH OF BIGHT	LARGEUR DE SURJET	UEBERWENDLICHBREITE	ANCHO COSTURA
Y	-	PASSO/FINITURA	DISTANCE/FINISHING	PAS/FINITION	TEILUNG/BEHANDLUNG	PASO/ACABADO
A	-	ACCIAIO	STEEL	ACIER	STAHL	ACERO
D	-	DENTATO	TOOTHED	DENTE	GEZAEHNT	DENTADO
G	-	GOMMATA	RUBBERED	CAOUTCHOUTEE	GUMMIBELAGTEN	ENGOMADO
W	-	WIDIA	WIDIA	WIDIA	WIDIA	WIDIA
★ ▲ ■ ●	-	ABBINAMENTI OBBLIGATORI	FIXED COUPLINGS	JUMELAGES OBLIGES	PFLICHT KOPPELUNGEN	COMBINACIONES OBLIGATORIAS



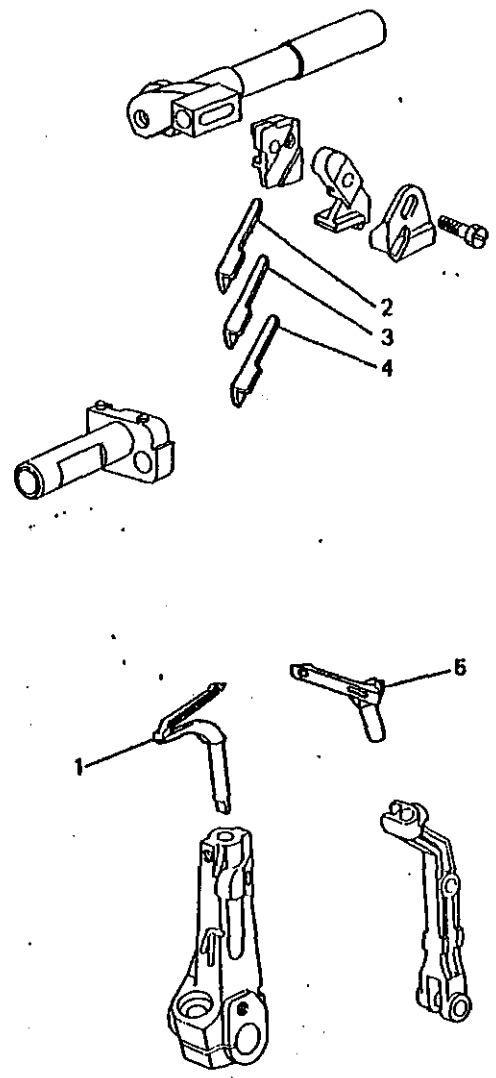

Fig. N.	Part. N. Piece N.	Qt.
1	209268-0-00	1
2	209352-0-00	2
3	209353-0-00	1
4	209354-0-00	2
5	211248-0-00	1

From the library of: Diamond Needs Corp

F24

Dalla matricola	n. 1206938
From serial	n. 1206938
A partir de la matricule	n. 1206938
Von seriennummer	n. 1206938
A partir de la matricula	n. 1206938

1a EDIZIONE - EDITION 5/93 **n.541/A**

PRINTED IN ITALY BY FEOPRINT - MILANO

**FLEXSYSTEM®**

**Vega**

**Nuovo Cinematismo  
New Kinematic Mechanism  
Nouveaux Mouvements  
Neves Kinematismus  
Nuevo cinematismo**

Varianti al Catalogo n. 541  
Le tavole barrate con la lettera A,  
annullano e sostituiscono  
le corrispondenti.

Variations to Catalogue n. 541  
Tables crossed with letter A,  
cancel and replace  
the corresponding ones.

Modifications au Catalogue n. 541  
Les tables barrees avec la lettre A,  
sont en substitution  
des correspondants.

Anderugen zu Katalog n. 541  
Die Blätter mit der Buchstabe A  
ersetzen die gleichen  
ohne Buchstabe.

Variaciones al Catalogo n. 541  
Las tablas con la indicacion A,  
anulan y sustituyen  
a las correspondientes.

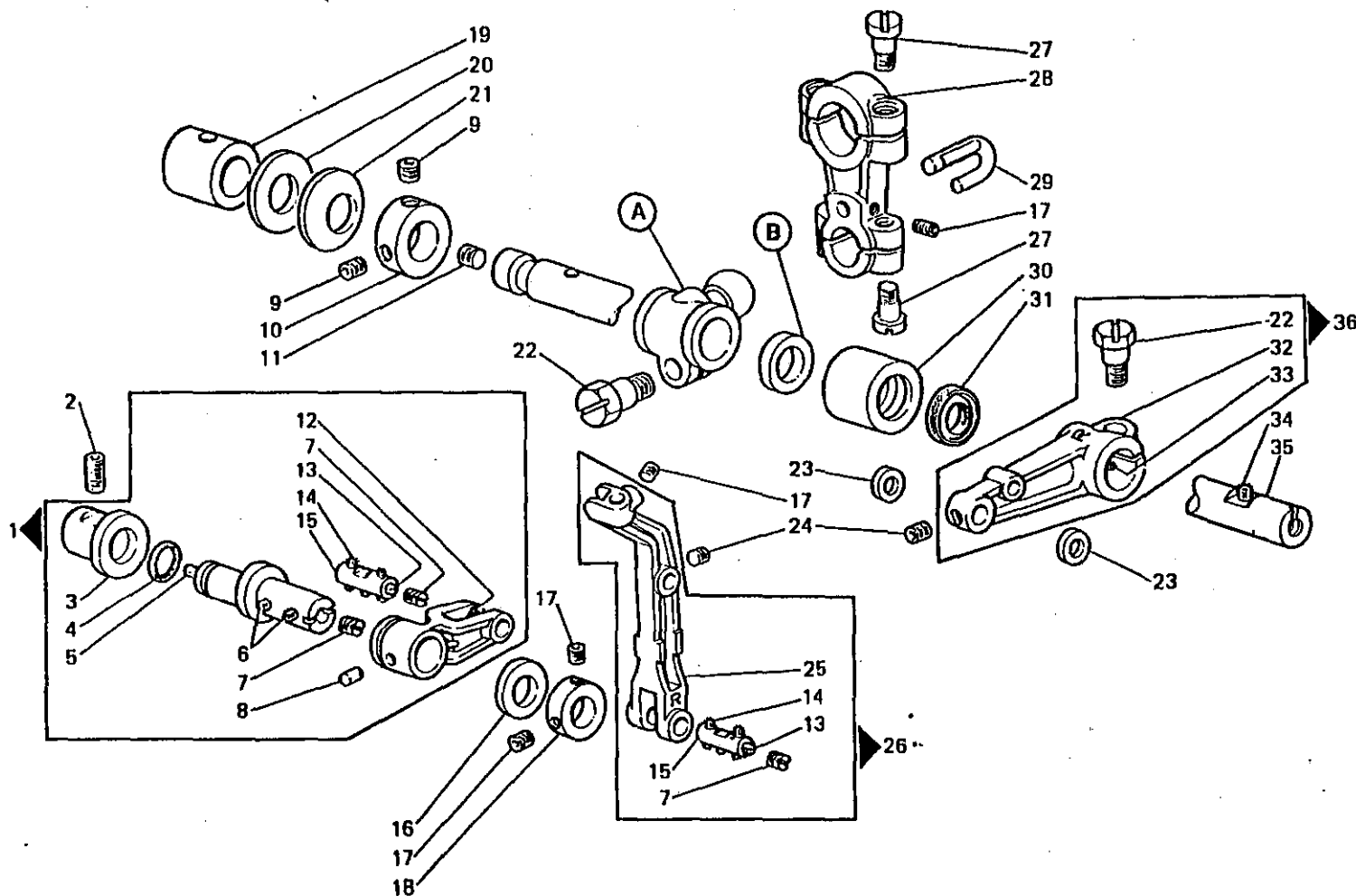

(A) (B)

F29-FS-2CD-AM	211221-2-00	704885-0-00
F29-FS-2CD-AN	211221-2-00	704885-0-00
F29-FS-2CD-BA	211221-2-00	704885-0-00
F29-FS-2CD-BB	211221-2-00	704885-0-00
F29-FS-2MD-AP	211220-2-00	704886-0-00
F29-FS-2MD-BC	211220-2-00	704886-0-00
F29-FS-3MD-BE	211220-2-00	704886-0-00

Fig. N.	Part. N. / Piece N.	Qt.
1	211245-3-00	1
2	729064-2-00	1
3	211239-0-00	1
4	701005-0-00	1
5	778411-0-00	1
6	778204-0-00	4
7	745002-0-00	2
8	310724-0-00	1
9	729013-2-00	2
10	313060-2-00	1
11	727036-2-00	1
12	778503-0-00	1
13	778403-0-00	2
14	778202-0-00	10
15	211208-4-00	2
16	704873-0-00	1
17	745812-2-00	4
18	211241-2-00	1
19	211209-0-01	1
20	705036-0-00	1
21	211281-0-00	1
22	201128-0-10	2
23	211213-0-00	2
24	745810-2-00	2
25	211216-0-00	1
26	211254-3-00	1
27	722089-2-00	4
28	209270-2-02	1
29	209272-0-00	1
30	211253-0-01	1
31	311166-0-00	1
32	211215-2-00	1
33	778419-0-00	1
34	778208-0-00	1
35	211280-4-10	1
36	211255-4-00	1

From the library of: Diamond Needle Corp

PER - FOR - POUR  
FÜR - PARA

- WFS-69-001-00-0
- WFS-69-002-00-0
- WFS-69-003-00-0
- WFS-69-004-00-0
- WFS-69-005-00-0
- WFS-69-006-00-0
- WFS-69-007-00-0
- WFS-69-008-00-0
- WFS-69-009-00-0
- WFS-69-010-00-0
- WFS-69-011-00-0
- WFS-69-012-00-0
- WFS-69-014-00-0
- WFS-69-015-00-0
- WFS-69-016-00-0
- WFS-69-017-00-0
- WFS-69-018-00-0
- WFS-69-019-00-0
- WFS-69-020-00-0
- WFS-69-021-00-0
- WFS-69-022-00-0
- WFS-69-023-00-0
- WFS-69-024-00-0
- WFS-69-025-00-0
- WFS-69-032-00-0

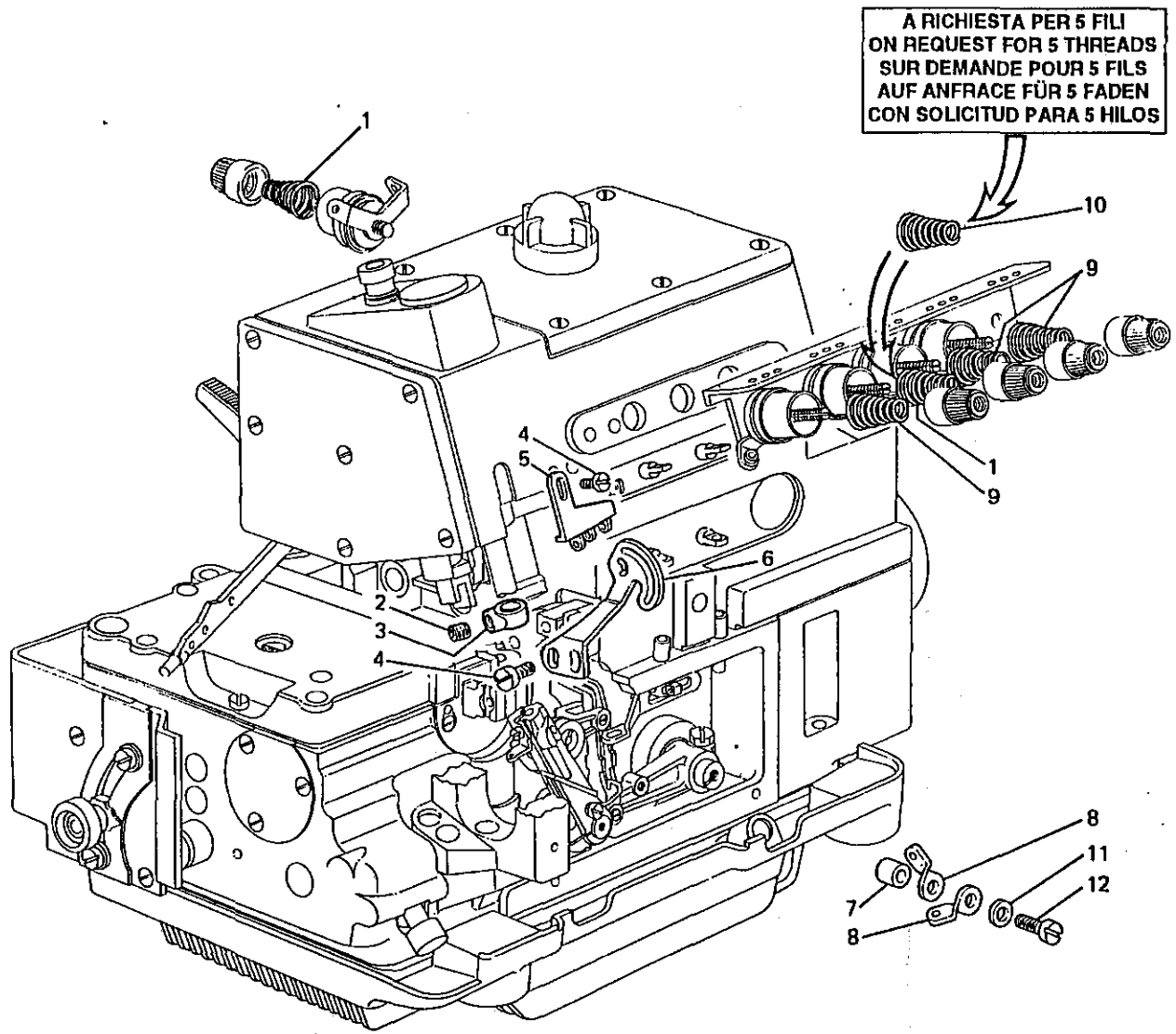

From the library of: Diamond Needle Corp

Fig. N.	Part. N. Place N.	Qt.
1	202681-0-10	2
2	745812-2-00	1
3	211125-0-00	1
4	741558-0-00	3
5	211143-0-00	1
6	211146-0-00	1
7	211742-0-00	1
8	211748-0-00	2
9	202227-0-10	3
10	202227-0-10	1
11	704104-2-00	1
12	722440-2-00	1

From the library of: Diamond Needle Corp

Dalla matricola	n. 1206938
From serial	n. 1206938
A partir de la matricule	n. 1206938
Von seriennummer	n. 1206938
A partir de la matricula	n. 1206938

# **FLEXSYSTEM<sup>®</sup>**

## **Vega**

**Nuovo Cinematismo  
New Kinematic Mechanism  
Nouveaux Mouvements  
Neves Kinematismus  
Nuevo cinematismo**

<b>TRASFORMAZIONI F29</b>
-------------------------------

1a EDIZIONE - EDITION 6/93 **n.541/B**

From the library of: Diamond Needle Corp

PRINTED IN ITALY BY FEOPRINT - MILANO

	A	B	C	D	E	F	G
F29-00-2CD-01	202227-0-10	211748-0-00	211222-0-00	211221-2-00	---	211255-4-00	211254-3-00
F29-00-2CD-03	202227-0-10	211748-0-00	211222-0-00	211221-2-00	---	211255-4-00	211254-3-00
F29-00-2CD-04	202227-0-10	211748-0-00	211222-0-00	211221-2-00	---	211255-4-00	211254-3-00
F29-00-2CD-05	202227-0-10	211748-0-00	211222-0-00	211221-2-00	---	211255-4-00	211254-3-00
F29-00-2CD-06	202227-0-10	211748-0-00	211222-0-00	211221-2-00	---	211255-4-00	211254-3-00
F29-00-2CD-10	202227-0-10	211748-0-00	211222-0-00	211221-2-00	---	211255-4-00	211254-3-00
F29-00-2CD-12	202227-0-10	211748-0-00	211222-0-00	211221-2-00	---	211255-4-00	211254-3-00
F29-00-2CD-15	202227-0-10	211748-0-00	211222-0-00	211221-2-00	---	211255-4-00	211254-3-00
F29-00-2CD-22	202227-0-10	211748-0-00	211222-0-00	211221-2-00	---	211255-4-00	211254-3-00
F29-00-2CD-23	202227-0-10	211748-0-00	211222-0-00	211221-2-00	---	211255-4-00	211254-3-00
F29-00-2CD-51	202227-0-10	211748-0-00	211222-0-00	211221-2-00	---	211255-4-00	211254-3-00
F29-00-2CD-55	202227-0-10	211748-0-00	211222-0-00	211221-2-00	---	211255-4-00	211254-3-00
F29-00-2CD-60	202227-0-10	211748-0-00	211222-0-00	211221-2-00	---	211255-4-00	211254-3-00
F29-00-2MD-05	202227-0-10	211748-0-00	211222-0-00	211220-2-00	704886-0-00	211255-4-00	211254-3-00
F29-00-2MD-06	202227-0-10	211748-0-00	211222-0-00	211220-2-00	704886-0-00	211255-4-00	211254-3-00
F29-00-2MD-10	202227-0-10	211748-0-00	211222-0-00	211220-2-00	704886-0-00	211255-4-00	211254-3-00
F29-00-2MD-55	202227-0-10	211748-0-00	211222-0-00	211220-2-00	704886-0-00	211255-4-00	211254-3-00
F29-00-2MD-56	202227-0-10	211748-0-00	211222-0-00	211220-2-00	704886-0-00	211255-4-00	211254-3-00
F29-00-2MD-60	202227-0-10	211748-0-00	211222-0-00	211220-2-00	704886-0-00	211255-4-00	211254-3-00
F29-12-2CD-02	202227-0-10	211748-0-00	211222-0-00	211221-2-00	---	211255-4-00	211254-3-00
F29-22-2CD-02	202227-0-10	211748-0-00	211222-0-00	211221-2-00	---	211255-4-00	211254-3-00
F29-22-2CD-03	202227-0-10	211748-0-00	211222-0-00	211221-2-00	---	211255-4-00	211254-3-00
F29-22-2MD-04	202227-0-10	211748-0-00	211222-0-00	211220-2-00	704886-0-00	211255-4-00	211254-3-00
F29-23-2CD-03	202227-0-10	211748-0-00	211222-0-00	211221-2-00	---	211255-4-00	211254-3-00
F29-23-2MD-04	202227-0-10	211748-0-00	211222-0-00	211220-2-00	704886-0-00	211255-4-00	211254-3-00
F29-49-2MD-01	202227-0-10	211748-0-00	211222-0-00	211220-2-00	704886-0-00	211255-4-00	211254-3-00
F29-49-3MD-69	202227-0-10	211748-0-00	211222-0-00	211220-2-00	704886-0-00	211255-4-00	211254-3-00

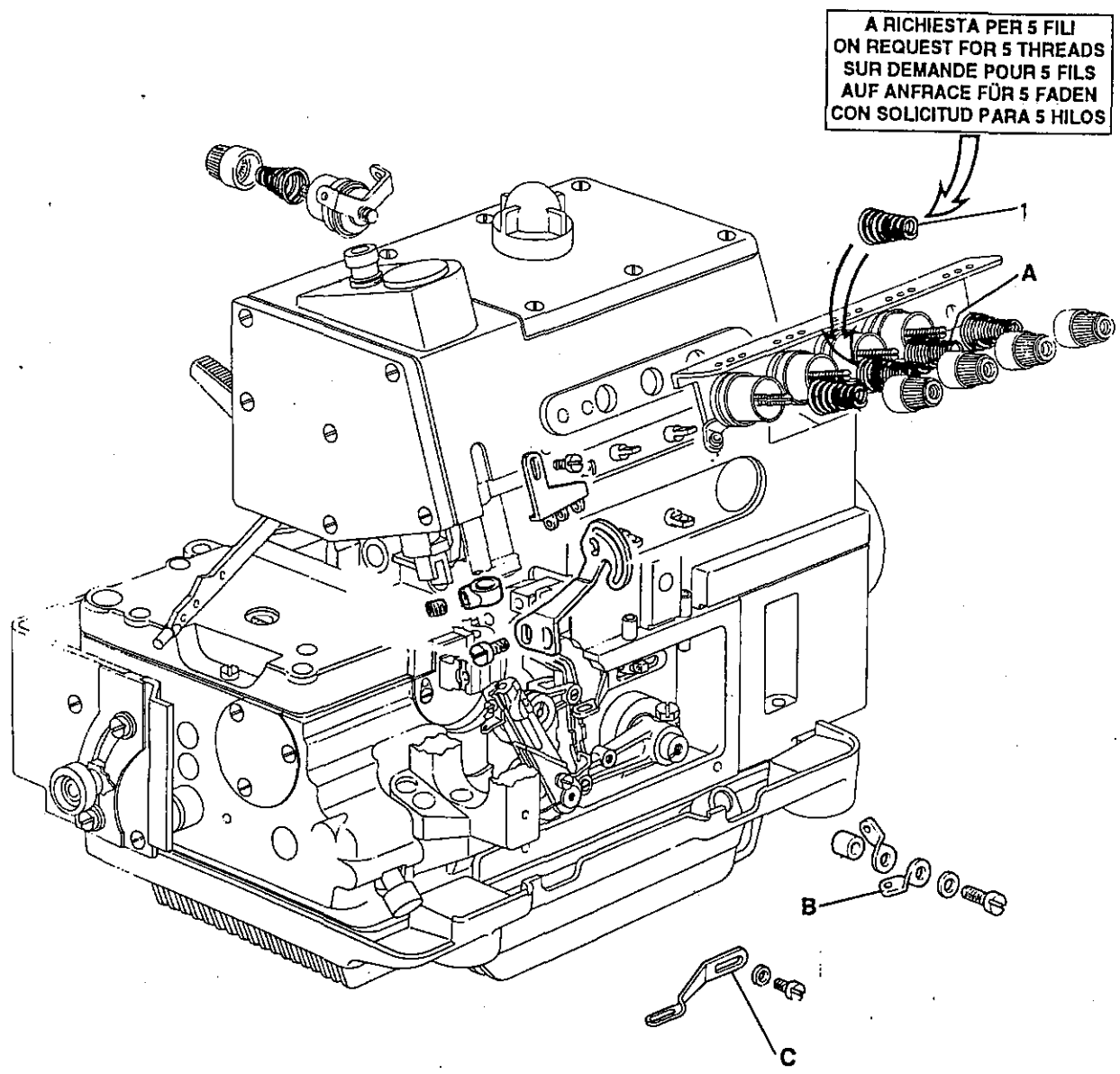

From the library of: Diamond Needle Corp

Fig. N.	Part. N. Place N.	Qt.
1	202227-0-10	1



Rim®

Fig. N.	Part. N. Place N.	Qt.
2	211215-2-00	1
3	211216-0-00	1

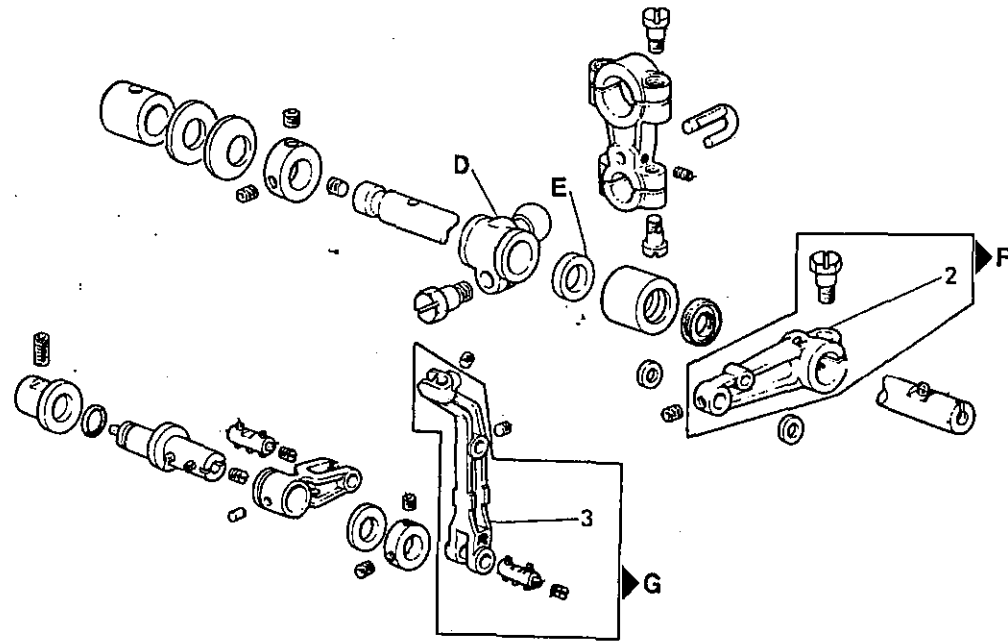

From the library of: Diamond Needle Corp